



TOWN OF DISCOVERY BAY

A COMMUNITY SERVICES DISTRICT

President - Chris Steele • Vice-President - Kevin Graves • Director - Brian Dawson • Director - Mark Simon • Director - Ray Tetreault

**NOTICE, CALL, AND AGENDA
OF A SPECIAL MEETING
OF THE BOARD OF DIRECTORS OF THE
TOWN OF DISCOVERY BAY CSD
February 8, 2012
SPECIAL MEETING at 6:30 p.m.
1800 Willow Lake Road, Discovery Bay, California
Website address: www.todb.ca.gov**

SPECIAL MEETING at 6:30 p.m.

A. ROLL CALL AND PLEDGE OF ALLEGIANCE

1. Call business meeting to order 6:30 p.m.
2. Pledge of Allegiance
3. Roll Call

B. PUBLIC COMMENTS (Public Comments will be limited to a 3-minute time limit)

The public may comment on any item on the Agenda that is before the Board for consideration. Any person wishing to speak must come up and speak from the podium. There will be no dialog between the Board and the commenter. Any clarifying questions from the Board must go through the Chair.

C. NEW BUSINESS AND ACTION ITEM

1. Review and accept the Water Master Plan and the Wastewater Master Plan for the Town of Discovery Bay Community Services District.

D. ADJOURNMENT

Adjourn to next Regular meeting of February 15, 2012 starting at 7:00 p.m. at 1800 Willow Lake Road- Located behind the Delta Community Presbyterian Church.

"This agenda shall be made available upon request in alternative formats to persons with a disability, as required by the American with Disabilities Act of 1990 (42 U.S.C. § 12132) and the Ralph M. Brown Act (California Government Code § 54954.2). Persons requesting a disability related modification or accommodation in order to participate in the meeting should contact the Town of Discovery Bay, at (925)634-1131, during regular business hours, at least twenty-four hours prior to the time of the meeting."

"Materials related to an item on the Agenda submitted to the Town of Discovery Bay CSD after distribution of the agenda packet are available for public inspection in the District Office located at 1800 Willow Lake Road during normal business hours."



Town of Discovery Bay

"A Community Services District"

AGENDA REPORT

Meeting Date

February 8, 2012

Prepared By: Rick Howard, General Manager and Virgil Koehne, Water and Wastewater Manager
Submitted By: Rick Howard, General Manager

Agenda Title

Review and accept the Water Master Plan and the Wastewater Master Plan for the Town of Discovery Bay Community Services District

Recommended Action

Review and accept the Water and Wastewater Master Plans for the Town of Discovery Bay; 2) Direct staff to identify capital financing alternatives and report back to the Board within 60 days, and 3) file an Exemption under CEQA.

Executive Summary

The Town of Discovery Bay Community Services District owns and operates a municipal water system that produces, treats and distributes potable drinking water to the community. The District also owns and operates a municipal wastewater treatment system that collects, treats and disposes of wastewater.

In 2010 the Board authorized contracts with Luhdorff & Scalmanini Consulting Engineers (May 5) and Stantec Engineering (June 16) to conduct extensive reviews of the District's Water and Wastewater systems, respectively. Both of these contracts resulted in the completion of a Water Master Plan and a Wastewater Master Plan. The master plans provide the District a long term (ten year) strategic look at the District's infrastructure needs. The master plans were developed in an effort to identify those improvements that are necessary to meet the existing and future development needs of the District for the ten year outlook period. The plans provide an extensive analysis of the water and wastewater systems of the District, incorporate those infrastructure and facility upgrades and improvements that are necessary to provide ongoing service to the existing community, and to plan for those facilities that are necessary to accommodate future development and anticipated residential growth.

The Master Plans include a number of projects that are necessary to meet existing service obligations. Some of those projects require immediate attention and will require significant financial resources in order to meet existing service obligations. As Discovery Bay West eventually builds out, the Pantages residential development project moves forward, and in-fill projects materialize, it will at that time become necessary to expand existing water and wastewater facilities to accommodate that growth. Once those projects trigger new facilities, those projects will be required to fund facility expansion to service obligations that are necessary to serve the new development.

The acceptance of the Master Plans provide the District the opportunity to formally seek and identify financing options for those projects that are necessary to construct during the ten year outlook period. It should be noted, however, that if the assumptions that direct the implementation of the improvements change, it may be necessary to modify the plans accordingly. Staff will continue to monitor those factors that may impact the plan in one manner or another and return to the Board as necessary with proposed amendments or changes to the plan.

It is recommended that the Board accept the Master Plans at this time. Plan recommendations and identified projects are for funding purposes only and are subject to necessary CEQA documentation.

Fiscal Impact:

Amount Requested \$ - None at this time

Previous Relevant Board Actions for This Item

May 5/June 16, 2010 Award of Master Plan Contracts – Water MP Workshop July 14, 2011 ;
Wastewater MP Workshop November 9, 2011

Attachments

1) Water Master Plan; 2) Wastewater Master Plan

AGENDA ITEM: C-1

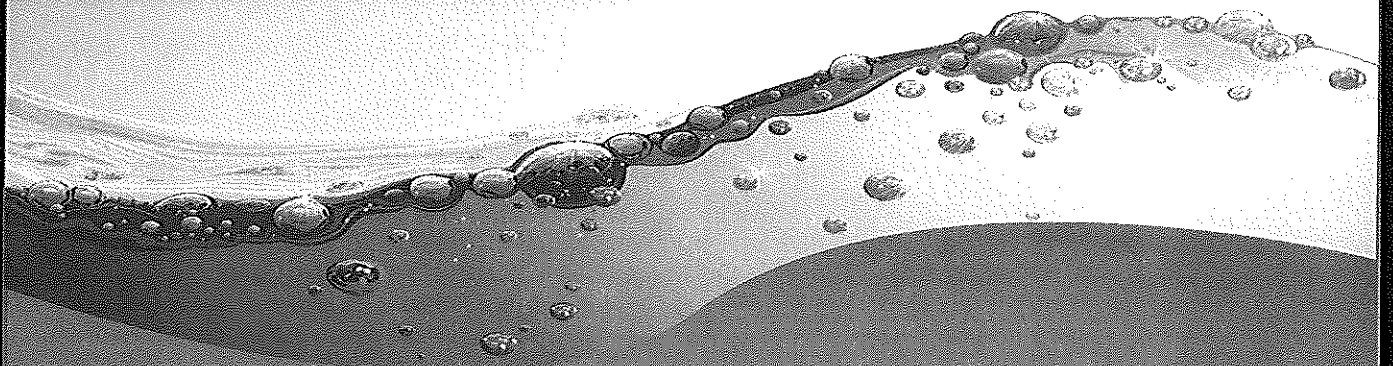

Discovery Bay Community Services District

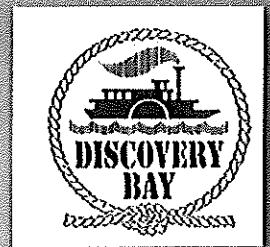
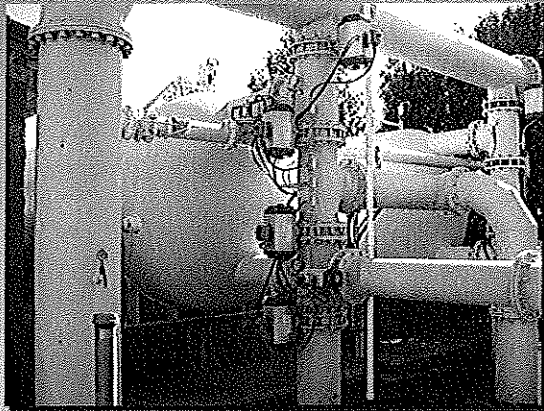

WATER MASTER PLAN

Final Report

January 2012



Prepared by:



LUHDORFF & SCALMANINI
CONSULTING ENGINEERS

WATER MASTER PLAN

DISCOVERY BAY



prepared for

Discovery Bay Community Services District

by

**Luhdorff & Scalmanini
Consulting Engineers
Woodland, CA**

January 2012

LSCE No. 10-5-070

Table of Contents

	Page
Executive Summary	ES-1
1. Introduction	1-1
1.1 Scope of Master Plan	1-2
1.2 Content and Organization.....	1-2
2. Water Requirements	2-1
2.1 Historic Water Production.....	2-3
2.2 Projected Water Requirements	2-3
2.3 Daily Water Demand and Peaking Factors	2-6
2.4 Water Conservation and Water Demand Management	2-8
3. Existing Water System.....	3-1
3.1 Overview	3-1
3.2 Water Supply Sources.....	3-1
3.2.1 Wells and Pump Stations	3-2
3.3 Water Treatment Plants.....	3-5
3.3.1 Willow Lake WTP.....	3-5
3.3.1.1 Greensand Filters	3-5
3.3.1.2 Storage Tanks	3-6
3.3.1.3 Boosters	3-6
3.3.1.4 Chemical Feed	3-6
3.3.1.5 Filter Backwash	3-6
3.3.2 Newport WTP	3-6
3.3.2.1 Greensand Filters	3-6
3.3.2.2 Storage Tanks	3-7
3.3.2.3 Boosters	3-7
3.3.2.4 Chemical Feed	3-7
3.3.2.5 Filter Backwash	3-7
3.4 Distribution System.....	3-10
4. Evaluation of Water System	4-1
4.1 Source Capacity.....	4-1
4.1.1 Source Capacity Requirements	4-1
4.1.2 Evaluation of Source Capacity.....	4-2
4.1.3 Source Capacity Reliability	4-3
4.2 Water Treatment	4-4
4.2.1 Water Quality Standards.....	4-4
4.2.2 Adequacy of Treatment Capacity.....	4-5
4.2.3 Evaluation of Backwash and Recycle Process.....	4-6
4.2.3.1 Willow Lake WTP	4-6

Table of Contents, continued

	Page
4.2.3.2 Newport WTP	4-7
4.2.4 Evaluation of Chemical Feed Equipment	4-7
4.2.4.1 Willow Lake WTP	4-7
4.2.4.2 Newport WTP	4-7
4.3 System Storage	4-7
4.3.1 Storage Requirements.....	4-8
4.3.2 Adequacy of Storage Capacity.....	4-9
4.4 Distribution System.....	4-9
4.4.1 Distribution System Requirements.....	4-10
4.4.2 System Hydraulic Model	4-10
4.4.3 Model Inputs and Scenarios	4-10
4.4.4 Calibration.....	4-12
4.4.5 PHD Simulations.....	4-12
4.4.6 MDD plus Fire Flow Simulations	4-12
4.4.7 Alternatives for Distribution System Improvements.....	4-13
4.4.8 Alternative Evaluation and Recommendation	4-14
4.4.9 Model Simulations with Improvements.....	4-15
4.4.10 Existing Pipeline Conditions.....	4-16
5. Groundwater Basin Assessment.....	5-1
5.1 Geologic Setting and Occurrence of Groundwater.....	5-1
5.2 Hydrogeologic Setting in Discovery Bay.....	5-2
5.3 Groundwater Conditions	5-3
5.4 Well Yields and Aquifer Characteristics.....	5-4
5.5 Groundwater Basin Yield and Monitoring.....	5-5
6. Capital Improvement Program	6-1
6.1 Overview	6-1
6.2 Prioritization and Schedule for Improvements	6-1
6.3 Unit Costs and Projected CIP	6-2
6.4 CIP Items.....	6-3
6.4.1. Source Capacity.....	6-3
6.4.2 Treatment Facilities	6-4
6.4.3 Distribution System.....	6-5
6.4.4 Storage Facilities	6-6
6.4.5 Groundwater Basin Management.....	6-7
6.4.6 Meter Upgrades.....	6-8
6.4.7 Corrosion System	6-8

Table of Contents, continued

	Page
7. References	7-1

Appendices

Appendix A: Water Quality Table (TDS and Specific Conductivity)

List of Tables, Figures and Plates

Tables

Table 2-1	Planned Growth by Development
Table 2-2	Existing and Projected Water Demand
Table 2-3	Existing and Future Water Requirements
Table 3-1	Well and Pump Information
Table 3-2	Filtration Unit Information
Table 3-3	Tank Information
Table 3-4	Booster Pump Information
Table 3-5	Estimated Length of Water Mains
Table 4-1	Current and Future Nominal Storage Requirements
Table 4-2	Distribution System Alternative Comparison
Table 6-1	CIP - Water System Improvements

Figures

Figure 1-1	Existing Water System and Future Developments
Figure 2-1	Annual Water Production
Figure 2-2	Water Requirements by EDU
Figure 4-1	Water Supply, Treatment and Storage Schematic
Figure 4-2	Water Supply and Treatment Improvements
Figure 4-3	Distribution System Improvements Alternative 1
Figure 4-4	Distribution System Improvements Alternative 2
Figure 5-1	Geologic Cross Section
Figure 5-2	Hydrograph for Supply Wells

Plates

Plate 1	Existing Water System and Future Developments
Plate 2	Pressure Contours of Distribution System at Build-Out PHD
Plate 3	Fire Flow Simulation Results at Build-Out MDD
Plate 4	Pressure Contours of Distribution System at Build-Out PHD w/ Improvements
Plate 5	Fire Flow Simulation Results at Build-Out MDD w/ Improvements
Plate 6	CIP Location Map

Executive Summary

Introduction

The Town of Discovery Bay Community Services District (District) owns water supply wells, treatment plants, storage tanks, and distribution system pipelines that serve water to about 16,000 people through 5,523 service connections for residential, commercial and irrigation uses in an approximate nine square mile area. This Water Master Plan document presents a systematic evaluation of the water system currently serving the Discovery Bay Community Services District and includes capital improvements to meet current and future water needs.

The Water Master Plan covers a ten year planning horizon that encompasses the incremental growth of planned developments. The District defined the areas of development and provided the estimated number of homes and schedule for completion based on discussions with local developers. The planned developments include a total of 1,355 residential service connections, 30 commercial connections and approximately 7 million gallons per year in additional irrigation connections.

The Master Plan document is intended to serve as a tool for the District to plan and budget for future facilities projects and capital improvements needed to ensure the District can continue providing adequate water supplies to the current and future customer base. The improvements that are recommended in this plan will allow the system to meet or exceed the standards for water source capacity, water treatment, storage and water distribution.

Water Requirements

Historical annual water production has grown from 286 million gallons in 1986 to about 1,335 million gallons in recent years. The recent addition of customer water meters has made it possible to evaluate water use by customer type (e.g. residential, commercial/institutional, irrigation, etc). A review of the residential metering data, starting in 2008, indicates that the average annual water consumption is on the order of 0.37 gallons per minute per residential service connection. A review of the metered water consumption in the other customer classes indicates the average annual water use expressed in gallons per minute for commercial/institutional is 1.56 gpm/connection and irrigation is 5.30 gpm/connection.

The average daily water demand for Discovery Bay is about 3.7 million gallons per day (MGD), or approximately 2,540 gallons per minute (gpm). The estimated future water requirements based on the expected growth equates to an increase in the total average daily demand to 4.6 MGD, or approximately 3,100 gpm. Using those water demands as a basis, peaking factors were

determined to estimate the maximum day and peak hour demand water consumption in accordance with regulatory guidelines. The maximum day demand and the peak hour demand water requirements are used in evaluating and sizing water supply, treatment, storage and distribution facilities in the system.

Recommended Water System Improvements

The existing Discovery Bay water supply, treatment, storage and distribution system is evaluated, and recommended system improvements are presented to meet the current and projected water demands. Recommended system improvements are presented that enable the District to meet the current and projected water demands through build-out in 2020. The evaluation is separated into six sections: water source capacity, water treatment, system storage, distribution system, groundwater basin management, and water conservation and water demand management. Below is a summary of the recommended improvements:

Source Capacity Recommendations

1. Construct a new water supply well to serve the Newport Water Treatment Plant (WTP). The new water supply well is needed immediately to improve water supply reliability and to serve projected growth and increasing water demands.
2. Upgrade the Well 1B pump unit to increase production to address a current deficiency in source capacity with the largest well offline.
3. Create a well replacement contingency fund to cover the failure (or decline in capacity) of an existing well site.

Water Treatment Recommendations

1. Construct a new water treatment filter unit, backwash tank and recycle pumps at the Willow Lake WTP by 2016 to meet projected water demand requirements.
2. Upgrade the filter face piping and valves on the existing water treatment filter units at Willow Lake WTP.
3. Upgrade the chemical disinfection facilities at Willow Lake.
4. Upgrade booster pumps at the Newport WTP.

System Storage Recommendations

1. Construct a new 275,000 gallon storage tank at the Newport WTP by 2014 to meet projected operational and fire safety storage requirements of the treatment plant.

Distribution System Recommendations

1. Install two new mainline canal crossings below Kellogg Creek to connect Discovery Bay Proper to the future Pantages development in order to improve fire flow performance in the system. Construct the mainline crossings concurrent with the schedule for Pantages development of 2017.
2. Install 7,350 linear feet of 16-inch mainline and valves to replace 8-inch mainline on Willow Lake Rd from Beaver Lane south to Discovery Bay Blvd in order to improve fire flow performance in the system and to begin replacing some older mainlines in the system.
3. Install 6,400 linear feet of 8-inch mainline and valves to replace 6-inch mainline on South Pt, Surfside Pl, Surfside Ct, Shell Ct, Beach Ct, Marina Cir and Lido Cir in order to improve fire flow performance in the system and to begin replacing some older mainlines in the system.

Groundwater Basin Management

1. Implement a groundwater basin management program that includes installing transducers in existing water supply wells, installing multi-aquifer monitoring wells, surveying wellheads, monitoring water levels and water quality, assessing water quality cross flow between aquifer units and estimating perennial yield.

Water Conservation and Demand Management

1. Install 3,907 customer water meters by 2019 as a method for managing water system demands and for compliance with regulations.
2. The District views the conservation of water to be an important component of ensuring the sustainability of their groundwater resource and realizes there may be a potential cost savings associated with not having to engineer and construct water infrastructure (wells, treatment units, storage tanks, distribution system pipeline), often linked to the ever increasing demand for water. The District will commission a water conservation feasibility evaluation that will establish water demand reduction goals consistent with the

California Department of Water Resources to reduce statewide per capita urban water use. The water conservation feasibility evaluation will include an assessment of the potential water conservation measures including the amount of water that could be saved for each measure and the planning-level cost to implement.

Capital Improvement Plan

The Capital Improvement Plan provides a summary of recommended improvements to the overall water supply, treatment, storage and distribution system; and a prioritization schedule for implementing the recommended improvements. Cost estimates are included for all improvements recommended. The costs provided include the present worth capital costs for complete installation, engineering, right-of-way, construction contingency, and construction administration.

The total Capital Improvement Plan includes \$10,392,880 in capital improvements and maintenance of critical facilities over the next 10 years. The primary concerns governing the schedule for improvements, in decreasing priority, were to install a new water supply well, begin a groundwater monitoring program, install a new water storage tank, install a new filter unit and related treatment equipment, and install numerous pipeline improvements. The CIP also includes a contingency for the future replacement of an existing well and pumping equipment.

1. Introduction

The Town of Discovery Bay Community Services District (District) owns water supply wells, treatment plants, storage tanks, and distribution system pipelines that serve water to about 16,000 people through 5,523 service connections for residential, commercial and irrigation uses in an approximate nine square mile area. The District's service area, illustrated on Plate 1 and on Figure 1-1, extends north from CA State Highway 4 about ten miles east of Mount Diablo and approximately five miles southeast of the City of Brentwood.

The District's service area includes seven existing developments: five are located in a portion of the system known as Discover Bay West (Village 1, 2, 3 and 4, and Ravenswood), and two are considered to be part of the older developments (Discovery Bay Proper and Centex). The developments receive treated groundwater from two water treatment plants (WTP), known as the Newport WTP and Willow Lake WTP. The sole drinking water source is groundwater provided from five supply wells located throughout the District. The Willow Lake WTP receives water from Wells 1B, 2 and 6; and the Newport WTP plant receives water from Wells 4A and 5A. Water storage tanks and booster pumps are located at both water treatment plants to provide water to the customers.

Total water requirements in Discovery Bay are currently about 1,335 million gallons per year (MGY), which equates to an average daily demand of about 3.7 million gallons per day (MGD), or about 2,540 gallons per minute (gpm). This Water Master Plan was prepared to cover a ten year planning horizon that encompasses the incremental growth of planned developments. The estimated future water requirements based on the expected growth equates to an increase in the total average daily demand to about 4.5 MGD, or about 3,100 gpm.

This Master Plan document presents a systematic evaluation of the entire water system, and includes analyses of the District's current and projected water consumption levels and patterns, water supply sources, treatment processes, and water storage and distribution system. System deficiencies are identified, and recommended improvements are identified and prioritized, and cost estimates are included for all recommended improvements. The District will be able to meet future water requirements by adding and/or upgrading the existing water supply wells, water treatment units, storage tanks and water distribution facilities.

The Water Master Plan is an important document that will be used by District staff and board members for planning purposes. Water supply, treatment, storage, and distribution facilities are not systems that are constructed and then remain unchanged for many years. Rather, water systems must evolve over time in response to changing (generally increasing) consumer demands and changing regulations that govern water supply and water quality. Additionally, as

new technologies are developed, opportunities to implement more efficient and/or environmentally acceptable solutions may arise. Accordingly, all water system owners must continually assess their facilities in the light of current and expected conditions and constraints and make changes to those facilities when appropriate. Efforts are required to keep the Plan current by adding new information as it becomes available. Major updates to the Water System Master Plan are recommended at five year intervals. The last Water Master Plan conducted on the Discovery Bay water system in 1999, and that document is referenced herein.

1.1 Scope of Master Plan

The scope of work included a comprehensive assessment and description of the District's ultimate needs (to the year 2020) for water distribution, supply, storage and treatment based on future increases in water demand associated with planned development. The resulting Master Plan document is intended to serve as a tool for the District to plan and budget for future facilities projects and capital improvements. The improvements identified in this Master Plan includes provisions that address current and future regulatory requirements, and includes upgrades aimed at increasing the reliability of water supply and treatment processes.

The overall scope for preparation of this Master Plan involved completion of a sequence of tasks that included the following:

- Definition of existing and potential future water demand;
- Evaluation of water supply and treatment facilities;
- Evaluation of the water distribution and storage system;
- Assessment of groundwater basin conditions and adequacy of water supply; and
- Development of recommended water system improvements and associated Capital Improvement Plan

1.2 Content and Organization

This Master Plan is organized into six chapters, including this Introduction (*Chapter 1*). Following this Introduction, *Chapter 2 - Water Supply Requirements* outlines the methodology used to review the District's past and existing water use patterns, and summarizes existing and potential future water requirements. Chapter 2 includes planning-level water demand projections that can be used as a basis for assessing the quantity and adequacy of existing water supply sources and the need for additional sources, and for evaluating the hydraulic performance of the storage and distribution system.

Chapter 3 - Existing Water System provides a description of the District's overall water system. That description serves as the background for the inventory and evaluation undertaken in

subsequent chapters of this Master Plan. Specific elements of the system description include the District's water supply source, the water treatment plant facilities, storage facilities, distribution pumping facilities, and the distribution piping as it relates to the ability to convey peak hour and fire demands.

Chapter 4 – Evaluation of Water System draws from the details of Chapters 2 and 3 and addresses the adequacy of the District's existing source capacity, treatment facilities, and distribution and storage facilities, with an evaluation of each to determine its adequacy or compliance with system requirements. That chapter includes a summary of applicable standards, e.g. the Waterworks Standards in the California Health and Safety Code (Title 22, Chapter 16), and generally accepted engineering and operating practices as applied in the water supply industry. Those summary standards and practices serve as the basis for assessing the overall system for adequacy. Chapter 4 also includes a description of the hydraulic model of the District's storage and distribution system, which permitted investigation and evaluation of responses of the distribution system and storage components to peak and emergency flows under future water requirements. Chapter 4 identifies system deficiencies that were noted and corrective measures that were evaluated such as new or replacement supply wells, additional treatment equipment, additional storage tanks, and additional pipelines.

Chapter 5 – Groundwater Basin Assessment provides an overview of the geologic and hydrogeologic setting as a foundation for understanding the District's sole source of water supply. Groundwater conditions are described in terms of water level and water quality. The most significant activity that the District must undertake to assure future reliability and optimization of its groundwater resource is systematic monitoring coupled with analyses of aquifer response under varying climatic and operational conditions ultimately leading to quantification of basin yield. Recommendations focus on implementing groundwater monitoring and interpretation while continuing with recently implemented biannual testing of each of the supply wells.

Chapter 6 – Capital Improvement Program provides a summary of recommended improvements to the overall water supply, treatment, storage and distribution system, including a schedule to prioritize the implementation of recommended improvements. Cost estimates are included in Chapter 6 for all improvements recommended. The cost estimates are in sufficient detail to show the major components of improvements. The costs provided are present day (current day costs not adjusted for inflation) and include cost of a complete installation, including engineering, right-of-way, contingency, and construction administration.

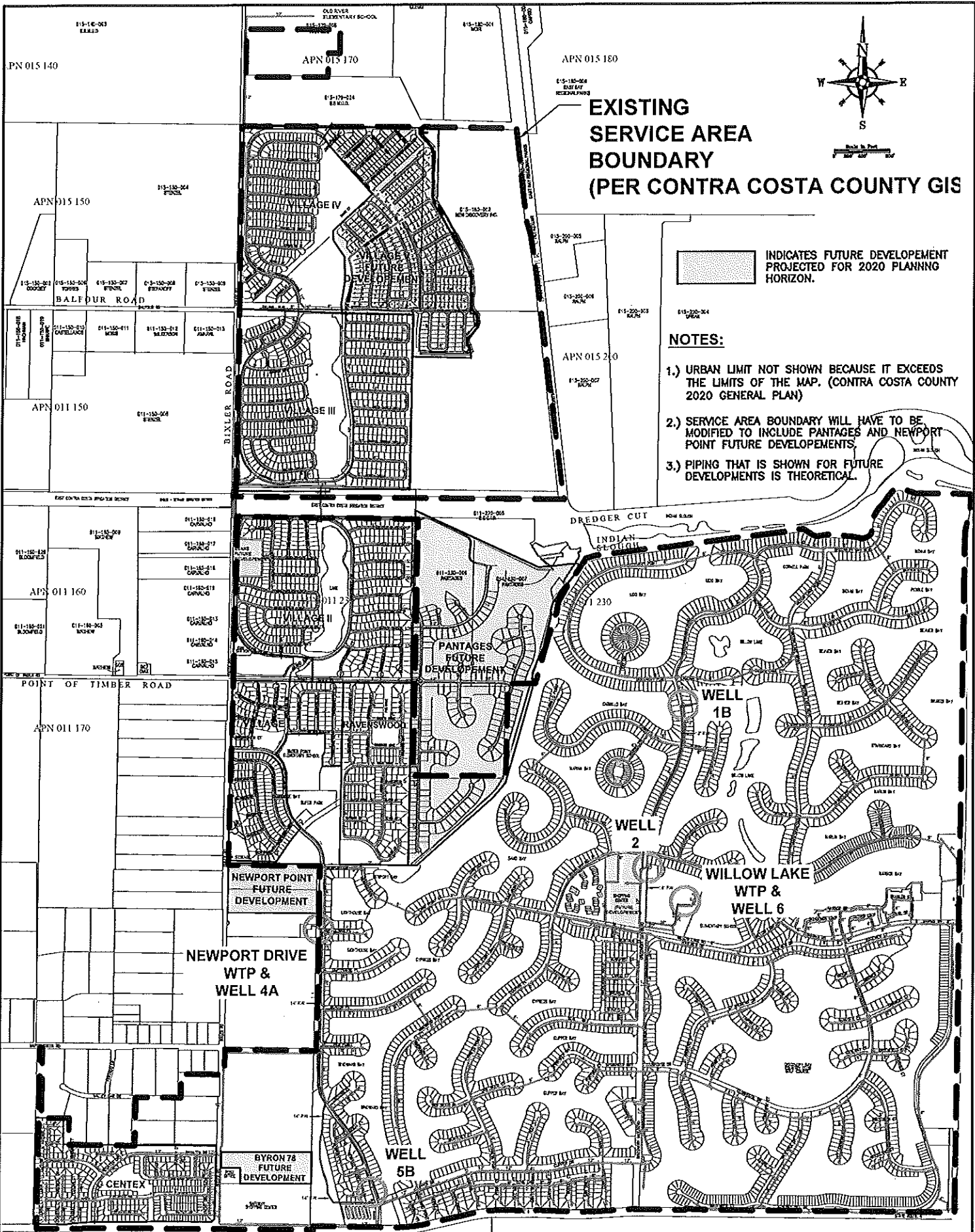

EXISTING SERVICE AREA BOUNDARY (PER CONTRA COSTA COUNTY GIS)

INDICATES FUTURE DEVELOPMENT PROJECTED FOR 2020 PLANNING HORIZON.

NOTES:

- 1.) URBAN LIMIT NOT SHOWN BECAUSE IT EXCEEDS THE LIMITS OF THE MAP. (CONTRA COSTA COUNTY 2020 GENERAL PLAN)
- 2.) SERVICE AREA BOUNDARY WILL HAVE TO BE MODIFIED TO INCLUDE PANTAGES AND NEWPORT POINT FUTURE DEVELOPMENTS.
- 3.) PIPING THAT IS SHOWN FOR FUTURE DEVELOPMENTS IS THEORETICAL.

2. Water Requirements

The District currently serves potable drinking water to an estimated 16,000 people via approximately 5,523 service connections. Of those, 5,147 are single family residential services, 222 are multi-family residential services, 28 are commercial and institutional, 96 are irrigation (e.g. parks, landscaping, etc.), and the remaining 30 are categorized as “Other”. The service connections designated as “Other” are for small uses such as drip systems used for soil moisture control along sidewalks and driveways to control shrinkage and swelling of clay soils.

This Water Master Plan was conducted with the assumption that the Plan would cover a ten year planning horizon and that most growth in that period would be driven by current plans from local developers. Some minor growth is associated with vacant lots that have water service connections but are undeveloped. The District defined the areas where growth is planned to occur and provided the estimated number of homes and schedule for completion based on discussions with local developers. The District also provided estimates of the landscape irrigation water requirements for the proposed developments based on their experience with similar landscaping in existing developments.

As shown in Figure 1-1 and Plate 1, some growth is expected to occur within the existing service area boundary, or “infill”, and some growth is planned to occur outside the existing service area boundary. Although there are additional undeveloped areas within the existing service area boundary, the Master Plan assumes that there will be no development in these areas for the 10-year planning horizon. The two developments planned outside of the service area boundary (Pantages and Newport Point) would require the District to modify the current service area boundary through approval from Contra Costa County Land Use and the Local Agency Formation Commission (LAFCO).

Future developments that are shown in Figure 1-1 and Plate 1 are conceptual layouts that reflect the total number of planned connections and theoretical piping to serve those connections. The developer’s actual plans may differ slightly, and it is the developer’s responsibility to ensure piping is sufficient to meet the expected needs of those developments.

Table 2-1 below presents the planned developments and the associated schedule for development. It should be recognized that the schedule, or rate of the planned development, is tied to economic conditions and other factors that are subject to change. As a result, the water demand projections provided in this chapter must be updated if the number of planned homes or the schedule for completion shown in Table 2-1 changes. However, it should be equally recognized that the water system improvements recommended in this master plan are tied with the schedule for development, and therefore future changes in the number or rate of development

will also necessitate changes in the timing of the recommend water system improvements presented in this master plan and detailed in the capital improvement plan. The District can formally address changes in the rate of development during the Water Master Plan updates that are recommended as a minimum to occur every five years.

**Table 2-1
Planned Growth by Development
Town of Discovery Bay**

Development Name	Residential ⁽¹⁾	Commercial/ Institutional ⁽¹⁾	Irrigation ⁽²⁾	Estimated Date of Completion
Discovery Bay (Proper)				
Vacant lots w/ SC (3)	151 SC	-	-	2013 - 2020
DB Shopping Center	80 SC	-	0.6 MGY	2015
Golf Course	13 SC	-	0.4 MGY	2015
Vacant 5 acre parcel	-	15 SC	-	2018
Centex (4)	-	-	-	-
Discovery Bay West				
Village I	12 SC	-	0.1 MGY	2013
Village II	56 SC	-	0.8 MGY	2014
Village III (3)	1 SC	-	-	2013
Village IV (3)	203 SC	-	-	2015
Village V	450 SC	-	2.6 MGY	2014 - 2016
Byron 78 (Sandy Cove)	-	15 SC	-	2015
Evans	19 SC	-	-	2015
Pantages (5)	300 SC	-	1.2 MGY	2016 - 2018
Ravenswood (4)	-	-	-	-
Old River Elementary (4)	-	-	-	-
Newport Point (5)	70 SC	-	1.3 MGY	2013-2014
Total	1,355 SC	30 SC	7 MGY	2013 - 2020

- (1) Residential and Commercial developments are indicated by the number of service connections (SC)
- (2) Irrigation demand for developments estimated by the District in million gallons per year (MGY).
- (3) These developments are vacant lots with existing (unused) water service connections; therefore, the District has committed to serve these customers in the future.
- (4) Centex, Ravenswood and Old River Elementary developments are complete and no development is planned.
- (5) Pantages and Newport Point are located outside of the existing service area boundary.
- (6) There are no additional service connections in the "other" category.

The planned developments shown in Table 2-1 also include water service allotments committed formally to developers by the District. There are approximately 355 residential water service connections that exist and are unused. These services are included in the “future” growth and it is assumed that the District has committed to serve these customers; the terminology “future committed” is used to describe these services. The remaining developments are planned, non-committed growth, which means developers have not received formal approval for those services and includes 1,000 residential service connections, 30 commercial/institutional service connections and the associated 7 million gallons per year (MGY) irrigation demand (estimated by the District).

2.1 Historic Water Production

Historical water production in million gallons per year (MGY) is depicted in Figure 2-1 for the period of 1986 to 2010. The water production data was obtained from flow meters installed on the District’s water supply wells and at the two water treatment plants (Newport WTP and Willow Lake WTP). The production data indicates steady growth in annual production from 286 million gallons in 1986 to 1,328 million gallons in 2008. There were a few years in that period when the annual production declined relative to the previous year (1991, 1998, 2006 and 2009). The occasional annual production declines in water production may be attributed to water demand declines due to seasonal weather variations, economic conditions that limit use of vacation homes, or water use reductions due to the introduction of water meters.

Figure 2-1 also shows the maximum monthly production for the period of 1995 to 2010. The growth in maximum monthly production generally coincides with growth in annual production. Recent data suggests the maximum month production generally ranges between 160 and 169 million gallons from 2006 to 2009. However, in 2010 the maximum monthly production increased to 217 million gallons while the annual production actually declined slightly. This anomaly is attributed to excessive and abnormal hydrant flushing that occurred during the month of August 2010 in response to customer complaints of brown water. The operators have since updated the hydrant flushing program to include more frequent routine flushing which has helped resolve most of the customer complaints.

2.2 Projected Water Requirements

A method to project water requirements, known as the *Disaggregate Method*, was utilized to evaluate existing water use and project future water requirements. In the *Disaggregate Method* the historic water deliveries are disaggregated into significant use classes, i.e. residential, commercial/ institutional, irrigation, and other. Based on water use in each sector, unitized water requirements are developed for an appropriate base unit in each class, e.g. gallons per day per residential unit, gallons per day per commercial/institutional service, etc. Projections are then

made from the expected number of growth in each class. Recent water meter data has made it possible to evaluate water use by customer type (e.g. residential, commercial, irrigation, etc).

Water deliveries to all customers have been historically sold on a flat rate system (non-volumetric) and previous estimates of water deliveries were obtained from flow meters at the supply wells and water treatment plant production records. In 2005, the District began installing customer water meters and establishing a billing system on a volumetric basis. The requirement for installing water meters has been mandated by the State of California (2006, *California Legislature AB 2572*).

Water delivery records for residences dates back to April 2008 with an initial metering of 62 residential units in the Village 4 subdivision. By the beginning of 2009 there were approximately 1,200 meters in service recorded on a monthly basis located throughout four different subdivisions (Village 1, Village 2, Village 3 and Village 4). Currently, there are approximately 1,900 residential water meters in service located throughout six different subdivisions (Village 1, Village 2, Village 3, Village 4, Ravenswood and Centex).

A review of the residential metering data described above indicates that the average annual water consumption is on the order of 0.37 gallons per minute per residential service connection (gpm/residential service connection). Typically, residential water use factors can be further subdivided into multi-family and single family if individual metering is done in each category, but the available metering data does not distinguish between multi-family and single family so the water use factor of 0.37 gpm/residential service connections is a weighted average of the metered cross-section of both types of residential dwelling. The multi-family water use makes up about 4-percent of the total residential sector so its use in that sector is small relative to the predominant residential water use and would not substantially affect the results of projecting water requirements in this Master Plan.

It was anticipated that an effect of metering customers would be a reduction in residential water use. However, based on the available meter data there has been no obvious reduction in residential water consumption. This can possibly be attributed to the low cost of water in Discovery Bay, and/or due to the limited number of residential meters and the limited time span of data available. The unit water consumption determined in this analysis (0.37 gpm/residential service connection) is nearly the same as the demand per dwelling unit (0.375 gpm/per dwelling unit) that was estimated in the 1999 Water Master Plan, indicating there has been little change in residential water consumption.

The other customer classes (commercial/institutional, irrigation and other) have been partially metered since 2005. A review of the metered water consumption in each class and the total number of meters in each class was conducted to obtain the annual average unit base demand for

each water use classification. From that review, the average annual water use, expressed in gallons per minute, for commercial/ institutional is 1.56 gpm/sc, irrigation is 5.30 gpm/sc and “other” is 0.05 gpm/sc.

The water use factors for each customer class discussed above and the rate of development presented in Table 2-1 were used to calculate the projected annual demand using the *Disaggregate Method*. The projected annual water demands are summarized in Table 2-2 (below) and indicate the average water demand at the planning horizon will be 3,100 gpm or approximately 1,630 million gallons per year (MGY). By comparison, applying the water use factors to the existing service connections in each customer class results in an existing average water demand of 2,540 gpm, or approximately 1,335 MGY. The existing average water demand estimate using the *Disaggregate Method* is comparatively close to the historic water production (i.e. 1,328 MGY).

**Table 2-2
Existing and Projected Annual Water Demand
Town of Discovery Bay**

Customer Type / Water Use Factor	Existing Service Connections and Estimated Water Use		Future Service Connections and Estimated Water Use	
	Service Connections	Estimated Water Use	Service Connections	Estimated Water Use
Residential (Single and Multi Family) 0.37 gpm/SC	5,369 SC	1,986 gpm	6,724 SC	2,488 gpm
Commercial/ Institutional 1.56 gpm/SC	28 SC	44 gpm	58 SC	90 gpm
Irrigation (see notes 1 and 2) 5.30 gpm/SC	96 SC	509 gpm	99 SC	524 gpm
Other 0.05 gpm/SC	30 SC	1 gpm	30 SC	1 gpm
Average Water Demand (gpm)	2,540 gpm		3,100 gpm	
Annual Water Demand (MGY)	1,335 MGY		1,630 MGY	

- (1) The Build Out water demand includes 7 MGY for landscape irrigation, estimated by the District. This demand translates to approximately 3 additional irrigation service connections based on current average irrigation water use (5.30 gpm/SC).
- (2) Average irrigation water use is 5.30 gpm/sc based on all metered irrigation services which range in size from 1-inch to 4-inch. Irrigation demands will vary based on the size of the connection and the specific landscaping needs. For example, a 1-inch irrigation service will use on average 1.3 gpm/sc, while a 2-inch uses on average 4.7 gpm/sc and 3-inch and 4-inch services use on average 18 gpm/sc. Among the 3-inch and 4-inch irrigation services, demands vary from 5 gpm/sc to 44 gpm/sc (all demands are shown in an annual average flow rate). The value of 5.30 gpm/sc is used in the Master Plan for the existing system, understanding that it is an average of the existing cross-section of irrigation services. When new irrigation services are added, consideration must be made for the proposed service size and the intended use of irrigation.

A useful tool in water demand assessment is to represent the demands of each customer type in terms of equivalence to a base unit. The system is comprised of a mixture of water uses consisting of four basic categories; residential, commercial, irrigation and other. By making the base unit equal to one residential unit, the demand of the entire system can be viewed in terms of total number of equivalent residential units being served. This is also known as an Equivalent Dwelling Unit (EDU). This representation is utilized here to show the growth in terms of number of the number of EDUs being served, which will be used later in the analysis for scheduling system improvements.

As determined above, the water use factor for the base unit is approximately 0.37 gpm per dwelling unit (0.37 gpm/EDU). The other water use factors are 1.56 gpm per commercial/institutional service connection, 5.30 gpm per irrigation service connection, and 0.05 gpm per other service connection. To determine the total EDU in the system, the water use factors are represented in terms of the equivalent number of dwelling (residential) units per service connection. By definition there is 1 EDU per residential service connection. There are 4.21 EDU per commercial/ institutional service connection, 14.32 EDU per irrigation service connection and 0.14 EDU per other service connection. The EDU factors are then applied to the total number of service connections in each category. The system in its current state serves approximately 6,865 EDUs. Including the 355 “future committed” residential connections (Table 2-1) the system has a future commitment level of 7,220 EDUs. At the planning horizon of 2020, with all proposed developments completed the system will serve approximately 8,380 EDUs.

With the recent development and use of SMART water meters and SCADA systems the District will be able to track and record flow rates and therefore enable further measurements of water use and water losses that can be used to accurately project water demands that may be associated with future planned developments. With the water metering becoming more available, the Discovery Bay water demands will be tracked by customer type and the demand can be separated or disaggregated into each type. Over time, the unit water use factors presented in this Master Plan can be updated as more meter data becomes available.

2.3 Daily Water Demand and Peaking Factors

As shown in Table 2-2, the current average water demand is 1,335 million gallons per year which equates to an average daily demand (ADD) of 2,540 gallons per minute (gpm). With that water demand as a basis, maximum-day and peak-hour factors are determined for the water supply source capacity sizing (maximum-day demand) and for storage and distribution system analysis (peak-hour demand).

Maximum Day Demand (MDD): The California Department of Public Health, California Waterworks Standards (Title 22) requires the District’s water supply and production capacities to

meet the maximum daily demand (MDD). More specifically, Title 22 requires the MDD be established from a minimum of 10 years of recent data. The determination of MDD must use daily usage records, if available. If daily records are not available (this is the case for the District), Title 22 permits the use of monthly records. In the absence of daily records, Title 22 states that the MDD is equal to the average day in the maximum month of production multiplied by a factor of 1.5. Note that the anomalous maximum month in August 2010 is disregarded as it reflected abnormal flushing activities in addition to regular customer water demands (Figure 2-1). For the District, the maximum month is July 2006 with a production of 169 million gallons (MG). The average day in July 2006 is approximately 5.5 MG. Thus, the estimated maximum day demand is 8.2 MG, or approximately 5,700 gpm. The ratio of the maximum day demand (5,700 gpm) to the average day demand (2,540 gpm) is 2.24. This ratio of the MDD to ADD (2.24) is called the MDD/ADD peaking factor.

Peak Hour Demand (PHD): The peak hour demand (PHD) is the peak flow rate that occurs over a period of several hours on the day of maximum use. Certain factors specific to each system affect the peak hour demand, such as irrigation timers and residential use patterns, which can be measured and represented by a system's diurnal curve if hourly data were available. In the absence of that information, Title 22 permits the use of a factor of 1.5 multiplied by the maximum day demand. In terms of average day demand, this results in an ADD to PHD peaking factor of 3.36. A previous demand evaluation conducted in the 1999 Water Master Plan determined that an adequate ADD to PHD peaking factor for Discovery Bay is 3.6. For planning and facility sizing purposes, this Master Plan takes the conservative approach of 3.6 times the ADD. The calculated peak hour demand is approximately 9,150 gpm (3.6 times the ADD flow of 2,540 gpm). This ratio of the PHD to ADD (3.6) is called the PHD/ADD peaking factor.

As shown in Table 2-2 (above), the estimated ADD at the planning horizon is approximately 3,100 gpm. Applying the peaking factors established above, the water demand at the planning horizon will be a MDD of 7,000 gpm and a PHD of 11,200 gpm. The adequate sizing of the water system facilities will also consider the maximum day demand plus fire flow. Commercial locations within the District require a fire flow of 3,000 gpm, as dictated by the Contra Costa Fire Department. The maximum day demand plus the fire flow at the planning horizon is 10,000 gpm. Table 2-3 (below) presents the summary of existing and future demands. The relationship between EDU and the projected ADD, MDD, PHD and MDD plus fire flow is represented in Figure 2-2.

**Table 2-3
Existing and Future Water Requirements
Town of Discovery Bay**

Level of Service	Average Day Demand (ADD)		Maximum Day Demand (MDD)		Peak Hour Demand (PHD)	
	(MGD)	(gpm)	(MGD)	(gpm)	(MGD)	(gpm)
Present (6,865 EDU)	3.7	2,540	8.2	5,700	13.2	9,150
Present + Future Committed (7,220 EDU)	3.9	2,700	8.6	6,000	13.8	9,600
Planning Horizon 2020 (8,380 EDU)	4.5	3,100	10.1	7,000	16.1	11,200

Note: MDD and PHD are based on the following peaking factors:

$$\text{MDD} = \text{ADD} * 2.24$$

$$\text{PHD} = \text{ADD} * 3.60$$

2.4 Water Conservation and Water Demand Management

The section includes a discussion of the District's current water conservation program and the District's approach to completing a Water Conservation Feasibility Evaluation to develop the basis for developing a formal water conservation and demand management plan. The District views the conservation of water to be an important component of ensuring the sustainability of their groundwater resource and realizes there may be a potential cost savings associated with not having to engineer and construct water infrastructure (wells, treatment units, storage tanks, distribution system pipeline), often linked to the ever increasing demand for water.

Current Water Conservation Effort

The District's current water conservation program includes informal inspections and follow-up communication with homeowner and commercial establishments that are knowingly or unknowingly using excessive amounts of water. In addition, the District has been proactive in installing water meters since 2005 (see above discussion). Installing water meters and billing customers on a volumetric basis can result in a reduction in water. Studies have shown that metered water systems that charge customers on a volumetric basis can use about 15 percent less than systems that do not have meters, and among those cities that do have volumetric rates, those with a tiered structure can use about 10 percent less than those who do not have a tiered structure.

Water Conservation Mandates

Water conservation is mandated by the State of California through recent legislature. The following is a brief description of recent water conservation legislature:

Assembly Bill 2572

Assembly Bill 2572 (AB 2572) requires that all urban water suppliers, such as the Discovery Bay CSD, install water meters on all municipal and industrial water service connections that are located in its service area on or before January 1, 2025 and begin billing all customers based on volumetric water deliveries.

Senate Bill X 7-7

The Senate Bill X 7-7 (SBX 7-7) *Water Conservation Bill of 2009*, was enacted to place the Department of Water Resources *20x2020 Water Conservation Plan* goal into statute (*2010, DWR Water Conservation Plan*). The goal is to reduce statewide per capita urban water use by 20 percent by the year 2020. To achieve this goal, urban water suppliers were supposed to include their baseline per capita water use, reduction targets and compliance analyses in the 2010 Urban Water Management Plan (UWMP). There is a milestone target of 10 percent reduction by 2015. Agencies that are not in compliance with SBX 7-7 by July 1, 2016 are not eligible for state water grants and loans. The DWR 20x2020 Water Conservation Plan also recommended moving the deadline for water meters in AB 2572 to 2020.

The proposed feasibility evaluation discussed below will address the 2015 and the 2020 water reduction goals of SBX 7-7.

Water Conservation Feasibility Evaluation

The District will commission a water conservation feasibility evaluation that will establish water demand reduction goals based upon the mandates discussed above. The evaluation will identify and include an assessment of water conservation measures that are feasible, cost effective, and readily implemented.

In assessing the feasibility of developing a Water Conservation and Demand Management Plan, the District will have the benefit of surveying already-existing water conservation programs that have proven track records for achieving effective water conservation. For example, the nearby communities of Petaluma and Pleasanton, with similar climate and similar water supply challenges, have active water conservation programs that can be referenced in completing the District's feasibility evaluation.

Water conservation measures to be considered in the water demand reduction evaluation will include:

- Residential Plumbing Retrofits (benefits of conserving showerheads, aerators, toilet flappers, and dye tablets, and the Ultra-Low Flow Toilet Rebate and the High-Efficiency Washing Machine Rebate Programs)
- System Water Audits, Leak Detection and Repair (use billing software to flag high consumer consumption rates and to identify leaks)
- Metering with Commodity Rates for all New Connections and Existing Connections (use of a tier rate structure based on water consumption to encourage water conservation)
- Large Landscape Conservation Program and Incentives (benefits of a establishing a Irrigation Equipment Rebate Program for high-use irrigation customers)

The water conservation feasibility evaluation will include an assessment of the potential water conservation measures including the amount of water that could be saved for each measure, planning-level cost to implement, and the benefits to the District, developer, and customer in meeting the water use reduction goals. Chapter 6 presents the Capital Improvement Plan and includes a CIP item for completing the Water Conservation Feasibility Evaluation.

Figure 2-1
Historic Water Production
Discovery Bay 2010 Water Master Plan

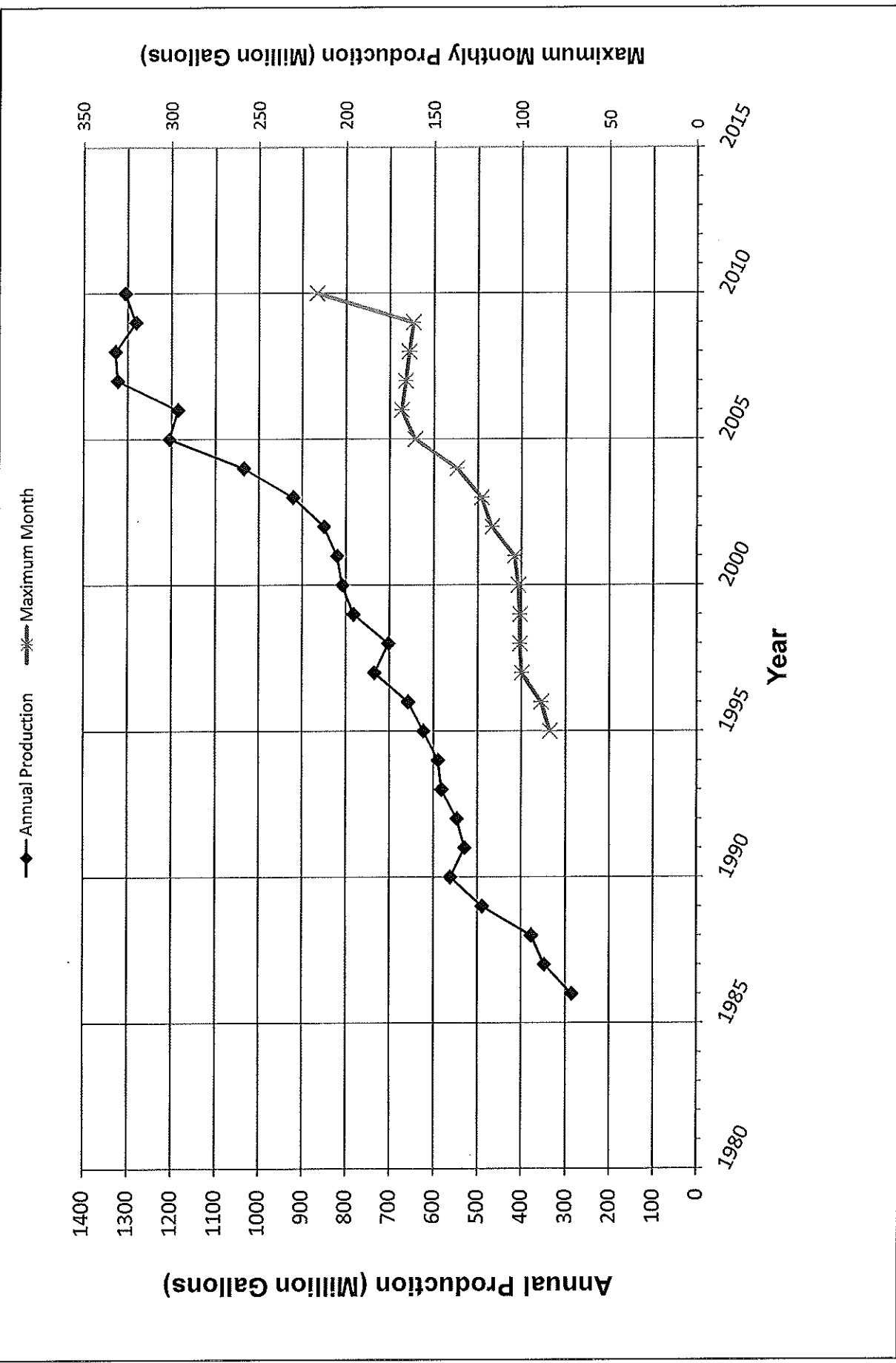

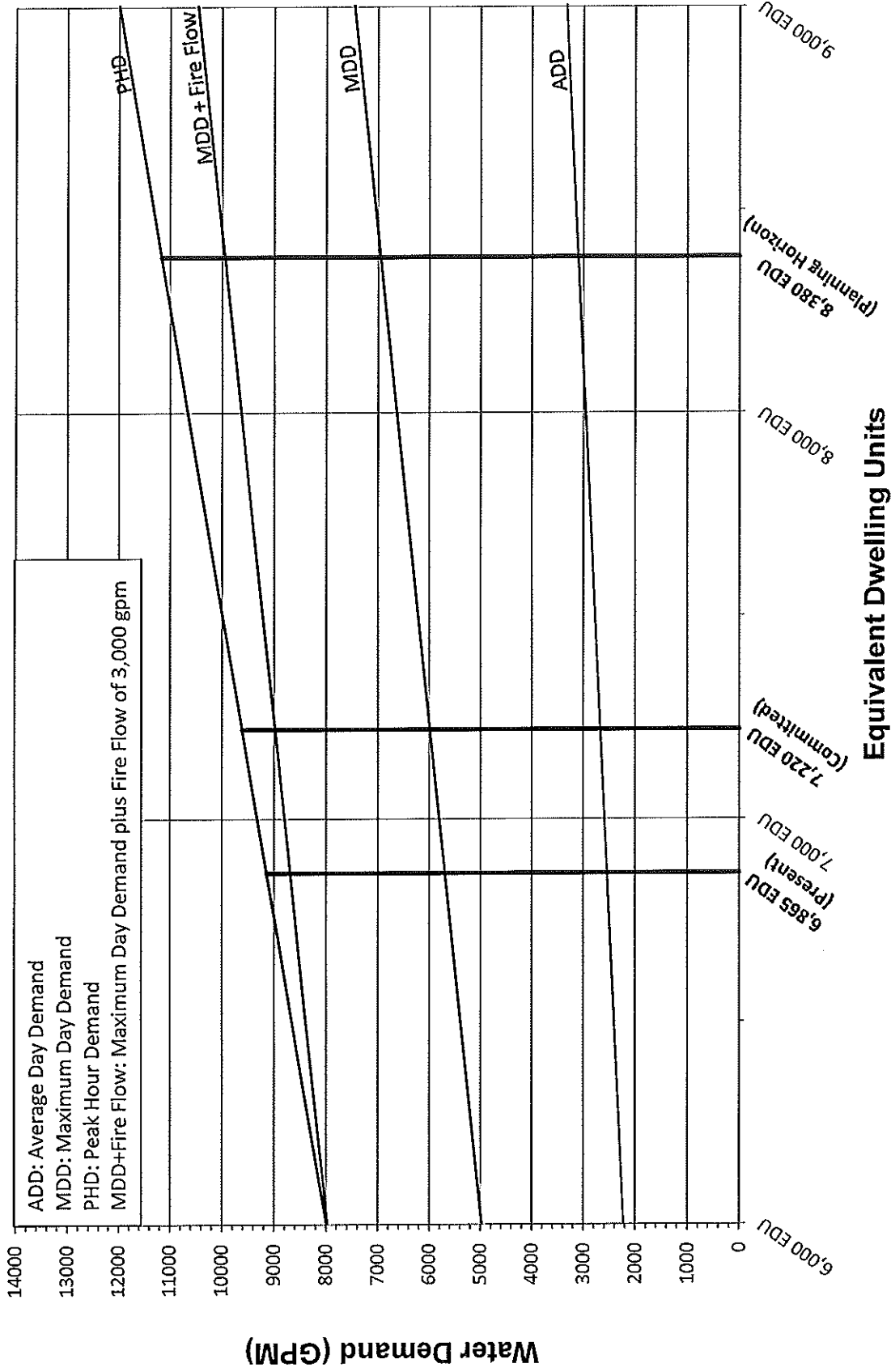

Figure 2-2
Water Requirements by EDU
Discovery Bay 2010 Water Master Plan

3. Existing Water System

This chapter describes the existing Town of Discovery Bay Community Services District water system. It is organized to include a general overview followed by detailed descriptions of the District's water supply sources, water treatment facilities, storage tanks, booster facilities, and distribution facilities.

3.1 Overview

The Town of Discovery Bay is located adjacent to the Sacramento-San Joaquin Delta approximately six miles southeast of the City of Brentwood off of Byron Highway, Interstate 4. Discovery Bay is situated within a network of man-made lakes and channels that are connected to the Delta. The community is largely residential with some commercial and irrigation uses. Most of the residential properties have docks with backyard access to the man-made channels and Delta waters. The levees and waterways of Discovery Bay are managed and maintained by Reclamation District 800 and the US Army Corps of Engineers. The system is defined by relatively flat topographies with mean sea level elevations ranging from 5 feet to 15 feet across the entire system.

The system derives all of its water supply from five active groundwater supply wells. Raw water from the wells is delivered and treated at two water treatment plants (WTPs), known as Newport WTP and the Willow Lake WTP. Storage tanks are located at each plant to provide operational equalization and reserves for fire safety. Booster facilities pump water from storage to provide the flow and pressure required in the distribution system. Each water treatment plant is equipped with standby generators to operate the facilities in the event of prolonged power outages. The distribution system consists of a network of piping varying in material and age ranging in diameter from 6-inch through 16-inch all in one pressure zone.

3.2 Water Supply Sources

There are five groundwater supply wells (Wells 1B, 2, 4A, 5A and 6) that deliver groundwater to the treatment plants through dedicated raw water pipelines. Wells 1B, 2 and 6 deliver water to Willow Lake WTP, and Wells 4A and 5A deliver water to the Newport WTP. Operation of the well pumps is controlled by the water levels in the storage tanks at the treatment plants. The District tests the supply wells every two years to assess well specific capacity and pump station performance.

The production rates are a function of many factors, but the key factors are the groundwater levels beneath the site, the well's specific capacity (expressed as the production in gpm per foot

of drawdown) and the pump performance characteristics. The total combined production from the wells ranges from approximately 7,400 gpm during summer dry year conditions to approximately 8,500 gpm during winter wet year conditions. A summary of the well and well pump information is presented in Table 3-1, below.

3.2.1 Wells and Pump Stations

Well 1B

Well 1B is located on the same site as former Wells 1 and 1A which have been abandoned. Well 1B is equipped with a pump designed to deliver 1,700 gpm to the Willow Lake WTP to meet the nominal capacity of two water treatment plant filters (i.e. 850 gpm per filter times two). The well has experienced a decline in specific capacity which in turn has increased the head condition on the pump. Attempts to rehabilitate Well 1B to increase capacities have been unsuccessful and as a result the pump can only deliver approximately 1,200 gpm to 1,600 gpm to the treatment plant depending on groundwater level conditions.

The District recently completed an investigation on Well 1B that evaluated the feasibility of upgrading the pumping equipment to increase production. The investigation considered the condition of the well, the current day specific capacity and the available drawdown in the well casing. The investigation also considered the limitations in the sizing of the electrical system and the cost to up-size the electrical system, if needed. Based on their investigation, the District determined that Well 1B can be upgraded with a new pump that will deliver between 1,500 gpm to 1,800 gpm (this improvement is included in the Capital Improvement Plan, Chapter 6).

Well 2

Well 2 is the oldest active water supply well in the system at approximately 40 years old. Well construction details are lacking, for example, the depth and quality of the sanitary seal are unknown. In addition, Well 2 is limited in pump capacity due to a 12-inch diameter well casing. Well 2 delivers water to Willow Lake WTP at flow rates approximately equal to the capacity of one treatment plant filter (i.e. 850 gpm per filter). Well 2 is the only well in the system equipped with an oil-lubricated pump.

Well 4A

Well 4A is approximately 15 years old and has been the most reliable producer in the system requiring a minimum amount of maintenance. Well 4A is equipped with a submersible pump that delivers 1,800 to 2,000 gpm to the Newport WTP (as originally designed for a 2,000 gpm filter at Newport). Well 4A is located at Newport WTP.

Well 5A

Well 5A is about 20 years old and has a history of maintenance efforts. The well has experienced corrosion problems that have caused damage to the well casing and column pipe. The well casing was patched in 1996 and the column pipe issues have been addressed with a protective coating system. There have also been issues associated with high total dissolved solids (TDS) and discoloration in the water. Well 5A is one of the highest producers in the system delivering 1,800 to 2,000 gpm to the Newport WTP. Issues associated with Well 5A corrosion are being addressed by a current maintenance program.

Well 6

Well 6 is the newest well in the system with construction completed in 2009. Well 6 was installed to provide a redundant supply for current water demands. The well is located at the Willow Lake WTP delivering raw water to the plant in conjunction with Wells 1B and 2. The well pump was designed to deliver 1,700 gpm during dry year conditions. Recent testing (Fall 2011) of the well specific capacity and review of water level data indicate the pumping equipment will deliver flows between 1,800 gpm and 2,000 gpm.

**Table 3-1
Well and Pump Information
Town of Discovery Bay**

	Well 1B	Well 2	Well 4A	Well 5A	Well 6
WELL INFO					
Drilling Date	1995	1971	1996	1991	2009
Well Diameter (inch)	16"	12"	16"	16"	18"
Well Depth (ft)	350'	348'	357'	357'	360'
Top Screen Interval	271'/289'	245'/335'	307'/347'	261'/291'	270'/295'
24-hr Specific Capacity ¹	11 gpm/ft	12 gpm/ft	23 gpm/ft	21 gpm/ft	28 gpm/ft
PUMP INFO					
Pump Type ²	Submersible	Oil Lube	Submersible	Water Lube	Submersible
Installation Date	2003	2003	2001	2004	2010
Pump Setting Depth (ft)	260'	220'	180'	240'	250'
Column Diameter (inch)	12"	8"	12"	10"	12"
Bowl Manufacturer	Byron Jackson	Goulds	Flowserve	Floway	Flowserve
Impeller Model	13MQH	11CHC	13MQH	14DKH	14EMM
Number of Stages	3	4	3	3	3
Motor Horsepower	150 HP	100 HP	150 HP	200 HP	150 HP
Well Control	Willow Tanks	Willow Tank	Newport Tanks	Newport Tanks	Willow Tanks
Capacity – Dry Year ³	1,200 gpm ⁴	800 gpm	1,800 gpm	1,800 gpm	1,800 gpm
Capacity – Wet Year ³	1,600 gpm ⁴	900 gpm	2,000 gpm	2,000 gpm	2,000 gpm

1. 24-hr specific capacity is based on well testing results during 2009 and 2010.
2. Oil Lube: oil lubricated lineshaft vertical turbine pump.
Water Lube: water lubricated lineshaft vertical turbine pump.
Submersible: submersible motor vertical turbine pump.
3. The pump capacities reflect the average output from the pumps during the dry year and wet year conditions, i.e. hydrologic conditions that cause groundwater levels to be characteristically deep or shallow. The capacities were approximated using well testing information, aquifer information, pump performance curves, and calculated system head curves. The capacities were also compared to production records at the individual wells and at the water treatment plants.
4. Upon completion of the Well 1B pump upgrade the well capacity is projected to range between 1,500 and 1,800 gpm. This will result in a total source capacity of 7,700 gpm during dry year condition and 8,700 gpm during wet year condition.

3.3 Water Treatment Plants

The District's water supply permit was amended by DPH in 2002 to include removal of manganese and iron at the two water treatment plants (Newport WTP and Willow Lake WTP). The treatment process is essentially the same at both plants. Groundwater from the wells is delivered to the plants. As raw water enters the plant it is pre-treated with sodium hypochlorite solution to target a chlorine concentration of 3 mg/L to oxidize soluble ions (e.g. manganese and iron), followed by greensand filters to remove precipitated solids. After the filtration process, water is directed to onsite storage tanks. The storage tanks provide equalization between the supply capacity and the peak demands. An onsite booster facility pumps from storage to supply the distribution network with treated drinking water. Each plant is equipped with four vertical turbine can booster pumps and two jockey pumps that work on variable speed drives to maintain a constant pressure to the distribution system. As water exits the booster facility post-treatment is provided with sodium hypochlorite to maintain chlorine residual in the system of 0.02 mg/L. Each treatment plant is equipped with a 750 KW diesel generator to provide backup power to the pumps during outages.

The greensand filters require backwashing to remove solids build-up in the filter media. Filter backwashing occurs when the differential pressure across a filter approaches 10 psi. During high demand periods each filter is backwashed daily. Backwash water is directed to a backwash reclaim tank where settling and decantation is performed. Water from the backwash reclaim tank is pumped to the treatment headworks at a rate of 10-percent total filter output (per the water supply permit requirements). The solids that accumulate in the bottom of the backwash tank are periodically pumped out and disposed of at the District's wastewater treatment facility.

Each water treatment plant component is described below. A summary of the filters, tanks and pumps at the treatment plants are provided in Tables 3-2, 3-3 and 3-4 below.

3.3.1 Willow Lake WTP

3.3.1.1 Greensand Filters

The Willow Lake WTP has three greensand filters; two were installed in 2002 when the plant was constructed and one additional filter was added in 2006 when the plant was expanded. Each filter has a nominal service flow rate of 850 gpm (in accordance with the manufacturer's specified filter bed loading rates). The combined nominal filter capacity of three filters is 2,550 gpm. Raw water from Wells 1B, 2 and 6 enters the treatment plant through a 16 inch pipe and is pretreated with chlorine prior to entering the filters. Flow control valves on the outlet piping of each filter limit the flow rates to approximately 850 gpm per filter. See Table 3-2.

3.3.1.2 *Storage Tanks*

The treatment plant contains two storage reservoirs constructed of bolted glass-fused steel. Each has a nominal storage volume of 750,000 gallons for a combined total of 1.5 million gallons (see Table 3-3).

3.3.1.3 *Boosters*

The combined output from the booster pumps has design capacity of 6,200 gpm at 70 psi (see Table 3-4). The booster pumps typically operate between 60 psi to 70 psi. The booster pumping equipment and electrical systems for the water treatment plant are housed in a CMU block building.

3.3.1.4 *Chemical Feed*

The chemical feed system consists of an 800-gallon sodium hypochlorite tank and dedicated chemical metering pumps linked to the operation of each water supply well (1B, 2 and 6). The chemical feed equipment is located in a separate room within the booster pump building. The chlorine feed system is equipped to provide injections of chlorine for pre-treatment and post-treatment (to the distribution system). In its current state, the Willow Lake WTP chemical room does not have sufficient electrical outlets to operate all metering pumps simultaneously, and the chlorine residual analyzer is not functioning. The chemical shelves and tubing are also heavily corroded.

3.3.1.5 *Filter Backwash*

Water to backwash the filters is supplied by the distribution system. Backwash water from the filters is routed to an 84,000-gallon backwash reclaim tank where the solids are allowed to settle. The backwash process generates approximately 16,000 gallons of backwash water per filter for a total of 48,000 gallons from all three filters. The filters are cleaned in sequence once per day during high demands and every 2 or 3 days during low demand periods. Recycle pumps take decant water from the backwash tank and deliver it to the raw water supply. There are two recycle pumps, each with a capacity of 190 gpm; one pump is for backup if the other one fails.

3.3.2 *Newport WTP*

3.3.2.1 *Greensand Filters*

The Newport WTP has two greensand treatment filters; one was installed in 2001 when the plant was constructed and an additional filter was added in 2004 when the plant was expanded. Each filter has a nominal service capacity of 2,000 gpm for a combined filter capacity of 4,000 gpm.

Raw water from Wells 4A and 5A enters the treatment plant through a 12 inch pipe that is pretreated with chlorine prior to entering the filter units. Flow control valves on the outlet piping of each filter limit the flow rates to 2,000 gpm per filter. See Table 3-2.

3.3.2.2 *Storage Tanks*

The treatment plant contains two storage reservoirs constructed of bolted glass-fused steel. Each has a nominal storage volume of 275,000 gallons for a combined total of 0.55 million gallons (see Table 3-3).

3.3.2.3 *Boosters*

The combined output from the booster pumps has design capacity of 6,000 gpm at 70 psi (see Table 3-4). The booster pumps typically operate between 60 psi to 70 psi. The booster pumping equipment and electrical systems for the water treatment plant are contained in a CMU block building.

3.3.2.4 *Chemical Feed*

The chemical feed system consists of an 800-gallon sodium hypochlorite tank and dedicated chemical metering pumps linked to the operation of each water supply well (4A and 5A). The chemical feed equipment is located in a separate block building. The chlorine feed system is equipped to provide injections of chlorine for pre-treatment and post-treatment (to the distribution system).

3.3.2.5 *Filter Backwash*

Water to backwash the filters is supplied by the onsite storage tanks and dedicated booster pumps. Backwash water is routed to a 100,000-gallon backwash tank where solids are allowed to settle. The backwash process generates approximately 32,000 gallons of backwash water per filter for a total of 64,000 gallons from both filters. The filters are cleaned in sequence once per day during high demands. Recycle pumps route the decant water in the backwash tank back into the raw water supply line to be recycled. There are two recycle pumps, each with a capacity of 200 gpm; one pump is for backup if the other one fails.

**Table 3-2
Filtration Unit Information (Greensand Media)
Town of Discovery Bay**

Location	Name	Year Installed	Diameter (feet)	Length (feet)	Surface Area (sq. ft.)	Surface Loading Rate (gpm/sq.ft.)	Nominal Capacity (gpm)
Willow WTP	Filter A	2002	8	14	120	7.1	850
Willow WTP	Filter B	2002	8	14	120	7.1	850
Willow WTP	Filter C	2006	8	14	120	7.1	850
Newport WTP	Filter A	2001	8	32	264	7.6	2,000
Newport WTP	Filter B	2004	8	32	264	7.6	2,000

**Table 3-3
Tank Information
Town of Discovery Bay**

Location	Name	Year Installed	Construction	Service	Nominal Capacity
Willow WTP	North	2002	Glass-fused bolted steel	Storage / treated water	750,000 gal.
Willow WTP	South	2002	Glass-fused bolted steel	Storage / treated water	750,000 gal.
Willow WTP	Backwash	2002	Glass-fused bolted steel	Filter Backwash	84,000 gal.
Newport WTP	North	2002	Glass-fused bolted steel	Storage / treated water	275,000 gal.
Newport WTP	South	2002	Glass-fused bolted steel	Storage / treated water	275,000 gal.
Newport WTP	Backwash	2002	Glass-fused bolted steel	Filter Backwash	100,000 gal.

**Table 3-4
Booster Pump Information
Town of Discovery Bay**

Location	Name	Year Installed	Type	Service	Horsepower	Head	Flow
Willow WTP	JB-1	2002	Vertical Turbine Can Pump	Jockey	25 hp	162 ft	500 gpm
Willow WTP	JB-2	2002	Vertical Turbine Can Pump	Jockey	25 hp	162 ft	500 gpm
Willow WTP	BP-1	2002	Vertical Turbine Can Pump	Booster	75 hp	162 ft	1,300 gpm
Willow WTP	BP-2	2002	Vertical Turbine Can Pump	Booster	75 hp	162 ft	1,300 gpm
Willow WTP	BP-3	2002	Vertical Turbine Can Pump	Booster	75 hp	162 ft	1,300 gpm
Willow WTP	BP-4	2002	Vertical Turbine Can Pump	Booster	75 hp	162 ft	1,300 gpm
Willow WTP	RP-1	2002	Centrifugal Single Stage	Reclaim	5 hp	70 ft	190 gpm
Willow WTP	RP-2	2002	Centrifugal Single Stage	Reclaim	5 hp	70 ft	190 gpm
Newport WTP	JB-1	2001	Vertical Turbine Can Pump	Jockey	25 hp	162 ft	500 gpm
Newport WTP	JB-2	2001	Vertical Turbine Can Pump	Jockey	25 hp	162 ft	500 gpm
Newport WTP	BP-1	2001	Vertical Turbine Can Pump	Booster	75 hp	162 ft	1,250 gpm
Newport WTP	BP-2	2001	Vertical Turbine Can Pump	Booster	75 hp	162 ft	1,250 gpm
Newport WTP	BP-3	2001	Vertical Turbine Can Pump	Booster	75 hp	162 ft	1,250 gpm
Newport WTP	BP-4	2001	Vertical Turbine Can Pump	Booster	75 hp	162 ft	1,250 gpm
Newport WTP	BW-1	2001	Vertical Turbine Can Pump	Backwash Supply	75 hp	70 ft	3,200 gpm
Newport WTP	BW-2	2001	Vertical Turbine Can Pump	Backwash Supply	75 hp	70 ft	3,200 gpm
Newport WTP	RP-1 ¹	2001 ¹	Centrifugal Multi-Stage	Reclaim	7.5 hp	70 ft	200 gpm
Newport WTP	RP-2	2001	Centrifugal Multi-Stage	Reclaim	7.5 hp	70 ft	200 gpm

1. The Newport reclaim pump RP-1 had the shaft seal replaced in 2009 due to failure.

3.4 Distribution System

The distribution system contains approximately 46 miles of mainline piping ranging in size from 6-inch to 16-inch. The system contains approximately 18 miles of asbestos cement (AC) pipe, 28 miles of PVC pipe and about 1 mile of cast iron and ductile iron pipe. Refer to Plate 1 and Table 3-5 for pipeline locations and diameters.

The original developments (i.e. Discovery Bay Proper) were constructed with AC pipe in the early 1970's, and over time some of its water mains have been replaced with PVC pipe. Discovery Bay Proper consists mostly of 8-inch and 12-inch mainlines, and the smaller individual streets are served by 6-inch and some 8-inch pipe. There are 11 pipe crossings in Discovery Bay Proper that loop mainlines together beneath the channels and creeks that surround the neighborhoods through 6 and 8-inch cement and motor lined iron pipe. The newer developments (i.e. Discovery Bay West) were constructed mostly of PVC pipe and contain larger diameters with 16-inch and 12-inch mainlines and 8-inch pipe on the smaller individual streets. A majority of the AC pipe and cast iron pipe crossings are about 40 years of age. The remaining water mains range from 10 to 30 years of age.

**Table 3-5
Estimated Length of Water Mains
Town of Discovery Bay**

	6"	8"	10"	12"	16"	20"	Total (feet)	Total (miles)
Existing System								
Discovery Bay Central, Centex	34,183	94,859		26,463	889	1,087	157,481	29.8
Village 1, Village 2, Village 3, Village 4		51,767	1,801	1,197	17,991		72,756	13.8
Ravenswood		9,824			2,122		11,946	2.3
Old River Elementary			2,850				2,850	0.5
Subtotal (miles)	6.5	29.6	0.9	5.2	4.0	0.2		46.4
Future System (theoretical piping)								
Village 5		22,362		150			22,512	4.3
Pantages		2,207	1,519	3,204	4,826		11,756	2.2
Subtotal (miles)	0	4.7	0.3	0.6	0.9	0		6.5
TOTAL (miles)	6.5	34.3	1.2	5.8	4.9	0.2		52.9

4. Evaluation of Water System

In this chapter, the existing Discovery Bay water supply, treatment, storage and distribution system as described in Chapter 3 is evaluated relative to the future system improvements needed in order to meet the projected water demands presented in Chapter 2. Each section presents the relative design criteria used in the evaluation. This evaluation is presented in four sections: source capacity, water treatment, system storage, and distribution system. Figure 4-1 presents a schematic of the recommended improvements to increase water supply, treatment and storage capacity to meet the required levels of service through the planning horizon.

4.1 Source Capacity

For purposes of this Master Plan, the term source capacity is considered to be the nominal rate at which the wells pump groundwater to the water treatment plants during a dry year condition, i.e. when the groundwater levels are seasonally lower and the resultant production rate from each well is less. Source capacity is a function of groundwater levels beneath the site, a wells' specific capacity (i.e. the production rate expressed as the flow in gpm per foot of drawdown), and the pumping equipment installed in the well. Over time the source capacity may decline as a result of the lowering groundwater water levels (due to changes in seasonal recharge or by over-pumping), a decline in well specific capacity (due to well clogging or other mechanisms), and/or a decline in the well pump or motor performance (well pump and motor wear with use). The Capital Improvement Plan includes provisions to monitor the groundwater basin, well performance and well pumping performance testing.

4.1.1 Source Capacity Requirements

The California Department of Public Health (CDPH) regulations, specifically Section §64554 of the California Waterworks Standards (Title 22, Chapter 16, California Code of Regulations, CCR); state: "at all times, a public water system's water source(s) shall have the capacity to meet the system's maximum day demand (MDD)." The source capacity is the estimated capacity of all sources of supply during the time at which the maximum day demand occurs. Title 22 also states that for water systems using only groundwater, "the system shall be capable of meeting MDD with the highest-capacity source off line". The Waterworks Standards also require that the system meet four hours of peak hourly demand (PHD) with source capacity, storage capacity, and/or emergency source connections. The latter requirement relates to the need to have sufficient storage and booster capability to maintain the peak hour demand.

4.1.2 Evaluation of Source Capacity

The total capacity from the wells during a dry year condition is approximately 7,400 gpm (Chapter 3). In accordance with the redundancy criterion in Title 22, i.e. to meet MDD with the highest capacity well offline, the source capacity of the water supply system is reduced to 5,600 gpm. The current MDD of the system is 5,700 gpm. The MDD will be 6,000 gpm when the service connections that are committed by the District become active. Based on all growth projected through the planning horizon the system will have a MDD of 7,000 gpm by the year 2020 (Chapter 2). Figure 4-2 shows the relationship between source capacity and current and future MDD.

The existing source capacity has a current shortfall of 100 gpm for the existing water demand, a shortfall of 400 gpm when including the committed service connections, and a shortfall of 1,400 gpm when including all projected growth through the planning horizon. Therefore, two recommended improvements are presented below: a) upgrade pumping equipment at existing Well 1B to meet current water supply shortfalls and some of the committed water supply shortfalls; and b) construct a new water supply well to meet the remaining water supply requirements through the planning horizon. These two improvements are discussed below:

Well Capacity Upgrade: A decline in specific capacity from Well 1B and Well 2 from historic levels has contributed to the current 100 gpm deficiency. To address the current deficiency the District is currently acting on recommendations for a well pump upgrade at Well 1B based upon the results of an investigation that evaluated trends in specific capacity and water levels and the capability of the mechanical and electrical equipment at the well site. Upon completion of the upgrade, production from Well 1B is projected to increase from 1,200 gpm to 1,500 gpm during dry summer conditions. This will result in an increase in source capacity to 5,900 gpm. With this improvement, there would temporarily no longer be a shortfall to meet the current MDD. There would still be a deficit of 100 gpm when including the committed service connections. Well 1B is an aging well that previously showed decline. The Well 1B improvement costs are relatively low compared to the benefit gained, i.e. increased capacity to meet current deficits. However, as discussed below it is possible for Well 1B and the other existing well structures to experience additional well specific capacity losses over time (through degradation and age) and planning for a new well is still recommended.

New Supply Well: As discussed in Chapter 3, the Willow Lake WTP is currently served by three supply wells (Well 1B, 2, and 6), whereas the Newport WTP is served by two supply wells (Wells 4A and 5A). Therefore, the largest operational impact to source capacity would occur if Newport WTP loses a well. Furthermore, Newport WTP is more dependent than the Willow Lake WTP on its full well source capacity to maintain operational levels in

the storage tanks. Therefore, it is recommended to construct the new well that is required to meet MDD through the planning horizon for the Newport WTP and target a flow rate of 2,000 gpm to meet the capacity of one filter. Well 5A could then become a back-up well and the new well would take over regular operation. With consideration for new homes beginning in 2013 (Chapter 2), and given a source capacity deficit for future committed service levels, a new water supply well is immediately needed and a capital expenditure is proposed during the first three years of the Capital Improvement Plan (See Chapter 6).

4.1.3 Source Capacity Reliability

To continue meeting the required levels of service there is a need to maintain the reliability of the existing well field and its source capacity. Source capacity can change over time due to varying causes. Some impacts gradually occur due to well material degradation processes associated with the environmental setting as the well ages. Well failure can also be catastrophic. For example, under some conditions the well structure degradation is so severe that the casing collapses which may result in a total loss of source capacity at a particular site. Reliability can be assessed by observing trends in well performance, visual inspection, and comparing the age to the service life of similar wells. The service life of a well depends on many factors such as its design elements and construction method, how it is operated, and long term degradation processes such as corrosion. A life span of modern wells typically used for planning is 50 years. Maximizing the life of a well is accomplished by regular inspection and maintenance, performance testing, and well rehabilitation, as needed.

The District's existing source supply wells were described in Chapter 3. Wells 2 and 5A are considered to be the least reliable and should be monitored, upgraded, or replaced as discussed below:

Well 2

Well 2 is the oldest well in the system constructed 40 years ago. Currently there are no evident structural problems with Well 2. However, if problems arise, the age of this well limits rehabilitation options. If Well 2 were to fail (either in degraded water quality or yield), a replacement well would be needed. The well field evaluation completed in this Master Plan indicates it may be possible to offset Well 2 by increasing production from other existing wells, although a formal assessment would be needed to confirm these initial findings.

Well 5A

Well 5A has a history of high maintenance needs and water quality issues. Specifically, Well 5A has experienced corrosion problems of both the well casing and the pump column pipe, and high TDS and water discoloration problems have been documented. This well is closely

monitored. The new well discussed in the previous section can take over regular service to the Newport WTP and Well 5A can become the back-up supply well to be maintained and exercised regularly, which will extend its useful life.

Although there is no immediate need to replace any of the existing wells, it is anticipated that a replacement well will be needed within the ten-year planning horizon and a contingency fund is recommended and has been included in the CIP program presented in Chapter 6. When a replacement well is installed, the well that it is replacing should be demolished and the well structure destroyed in accordance with state and local regulations to protect source water quality.

4.2 Water Treatment

This section evaluates the performance of each component of the existing water treatment plant and identifies improvements in order to bring the overall plant into conformance with regulations and standards of good engineering practice. The evaluation below presents the basis for water treatment improvements (water quality standards and DPH requirements) and the resultant upgrades and improvements to the filter units, and the filter backwash and recycle unit processes.

4.2.1 Water Quality Standards

The water quality standards for the Discovery Bay drinking water are dictated by the primary and secondary maximum contaminant levels (MCLs) as set forth in the Federal and State Drinking Water Standards. While the Discovery Bay raw water supply (groundwater from wells) meets primary MCL standards, it exceeds the secondary MCL for manganese and iron. The historic records indicate raw water supplied from Wells 1B, 2, 4A, 5A and 6 have manganese levels that generally range from 100 parts per billion (ppb) to 200 ppb. The secondary MCL for manganese is 50 ppb. To a lesser extent iron has been an issue in the raw water supply, and there has been an occasional exceedance of the secondary MCL for iron (300 ppb).

The raw water supply also contains levels of total dissolved solids (TDS) that are near the maximum contaminant levels. Well 5A typically has the highest levels of TDS generally varying between 550 parts per million (ppm) to 750 ppm. The CDPH set three levels for TDS: recommended MCL of 500 ppm; an upper MCL of 1,000 ppm; and a short term MCL of 1,500 ppm. Well 5A exceeds the recommended level but is below the upper level, which means it is acceptable if it is neither reasonable nor feasible to provide more suitable water. Treatment of TDS is relatively expensive as it involves membrane or reverse osmosis technology; therefore, treatment of the Well 5A source for TDS is not reasonable. The District closely monitors TDS from all wells. See Chapter 5 for additional discussion of TDS water quality in the groundwater aquifer systems.

Although the raw water is generally compliant with the primary MCLs, there have been some detections above the MCL. In addition there are proposed changes to some MCLs as discussed in more detail below.

In 2008 three supply wells had cyanide detections that exceeded the MCL of 0.15 ppm. In general, historical water quality tests from the wells have been non-detect for cyanide. Following the exceedance in 2008, the CDPH required four consecutive quarters of monitoring, which resulted in levels below the MCL indicating the 2008 samples were anomalous, and no corrective action was required.

Levels of arsenic have been found in the wells, but never in exceedance of the primary MCL or the trigger level. The trigger level for arsenic is 5 ppb and constituents that exceed the trigger level usually require additional monitoring. The historic concentrations of arsenic vary in the wells, but in general concentrations are between 0 ppb to 4 ppb. However, samples collected in 1989 and 1990 from Wells 2 and 5A each resulted in an arsenic concentration of 10 ppb, which did not exceed the MCL that was enforced at that time of 50 ppb. The primary MCL for arsenic was lowered to 10 ppb in 2006. No action has been required by CDPH because the levels of arsenic have always been below the required water quality limit. At this time no upcoming changes in the MCL for arsenic are proposed by CDPH.

CDPH indicates that a MCL will soon be established for hexavalent chromium. Currently, hexavalent chromium is regulated through the establishment of an MCL for total chromium of 50 parts per billion. Historical water quality records indicate total chromium has been typically non-detect. In addition, the District has taken a pro-active approach and started sampling for hexavalent chromium. Initial test results for hexavalent chromium are non-detect at a detection limit of 1 part per billion.

4.2.2 Adequacy of Treatment Capacity

For the Discovery Bay system, the capacity at which raw water can be treated is the nominal capacity of the iron and manganese filter units. The combined treatment, or filter, capacity of the system must be capable of meeting the MDD so as to not limit the ability of the wells to meet the MDD. The total filter capacity of both water treatment plants combined is 6,550 gpm; that is 4,000 gpm at the Newport WTP and 2,550 gpm at the Willow Lake WTP (Chapter 3). The current filter capacity (6,550 gpm) exceeds the current MDD (5,700 gpm). However, in order to meet the MDD through the planning horizon (7,000 gpm) the filter capacity needs to be expanded by at least 450 gpm. The timing or need for an additional filter unit is tied to the rate of infill development. The existing filters can treat up to 7,920 EDU. According to the estimated rate of development, defined by Table 2-1 (Chapter 2), the system will reach 7,920 EDU in 2016.

Therefore, it is recommended that a new filter be constructed and brought on-line by this time. Figure 4-2 shows the relationship between filter capacity and current and build-out MDD.

The filters at the treatment plants are sized based upon matching capacities of the wells. The Willow Lake WTP has filters that operate at 850 gpm and the wells deliver nominally 850 gpm and 1,700 gpm. Newport has filters that operate at 2,000 gpm and the wells deliver nominally that amount. Based upon treatment plant operation, and on the ultimate need for an additional 450 gpm of filter capacity at build-out, the system can most efficiently expand its filter capacity with a new 850 gpm filter at the Willow Lake WTP. Willow Lake WTP is also centrally located in the system and contains a majority of the system storage, making it the best candidate for expanded production flows. With the addition of a new filter, the treatment capacity at Willow Lake WTP will be increased to 3,400 gpm and the total filter capacity of the combined Newport and Willow Lake treatment systems will be 7,400 gpm.

The proposed expansions to the Willow Lake WTP maximize the useful production and space limitation for this site. Any future development beyond the ten-year horizon presented in this Master Plan may require the design and installation of a new water treatment plant.

4.2.3 Evaluation of Backwash and Recycle Process

4.2.3.1 *Willow Lake WTP*

As discussed in Chapter 3, the Willow Lake WTP has an 84,000-gallon backwash tank. There is approximately 60,000 gallons of usable volume. Each filter generates approximately 16,000 gallons of backwash water; with three filters the total backwash water generated is 48,000 gallons. According to water system operators, backwash cycles are sometimes extended to improve filter performance, increasing the backwash water generated per cycle. During high demand periods the three filters are backwashed once per day. In addition, water operators have observed backwash tank levels slowly rising after a backwash cycle has ended, indicating that some of the face piping valves may be leaking. Based on these observations the existing backwash tank cannot sustain increased backwash flows.

The addition of a fourth filter at Willow Lake WTP increases the backwash water generated, requiring additional backwash storage. Space is limited at the Willow Lake WTP; one potential location is behind the existing office trailer. A new 50,000 gallon backwash tank is recommended to supplement the existing backwash tank for the existing and future needs of the treatment plant process. The tank should be designed to operate with the existing backwash tank and filters with the option to use the tanks independently.

Finally, with a new backwash tank and filter at Willow Lake WTP, a new recycle pump would need to be constructed to provide recycling rates at 10-percent of filter production, or up to 340

gpm. The existing recycle pumps are about 10 years old and may require replacement within the next 10 years. It is recommended that three new recycle pumps be installed during construction of the filter and the backwash tank to supply a recycle water flow rate of up to 340 gpm.

4.2.3.2 *Newport WTP*

Newport WTP has a 100,000 gallon backwash tank with a usable volume of approximately 86,000 gallons. The filters are backwashed every day. Each filter generates approximately 32,000 gallons of backwash water. With two filters the total backwash volume is 64,000 gallons. No additional volume is needed.

The existing reclaim pumps are about 10 years old and therefore a pump upgrade/replacement is recommended, and is planned and budgeted in the Chapter 6 Capital Improvement Plan.

4.2.4 Evaluation of Chemical Feed Equipment

4.2.4.1 *Willow Lake WTP*

At the Willow Lake WTP, the chemical feed room is equipped with three metering pumps, one for each supply well (1B, 2 and 6). The metering pumps are programmed through the PLC to turn on with operation of a well pump. Currently, there are not enough electrical outlets to have all three metering pumps operating, and thus all three well pumps cannot be operated at the same time. In addition, the process tubing and the wooden shelves in the chemical room have become corroded and worn, and the chlorine analyzer is not functioning. A chemical room upgrade at Willow Lake WTP is recommended and included in the CIP to update the electrical circuitry and replace process tubing and metering pump shelves.

4.2.4.2 *Newport WTP*

The Newport WTP chemical feed equipment is currently set up for operation with two wells (Well 4A and Well 5A). The chemical room must be updated for addition of the third well during its design and construction and the Chapter 6 CIP includes provisions for this upgrade.

4.3 System Storage

This section evaluates the adequacy of total system storage relative to the design criteria for storage.

4.3.1 Storage Requirements

The functions of system storage are to provide water for operational equalization, fire flow and emergency. The specific storage requirements are discussed in more detail below.

Operational Storage - Title 22 states that the system shall meet at least four hours of peak hourly demand through source supply, storage and emergency source connections. Review of previous diurnal curve information indicates the PHD at Discovery Bay occurs over a period of 4 hours (1999, LSCE). The PHD of the system is 9,150 gpm currently and is project to be 11,200 gpm at build out (Chapter 2). At current water demands, the tanks will deliver 2.20 million gallons (MG) during four hours of PHD. The supply to the tanks, based on well and filter capacity, will fill 1.6 MG in 4 hours. Thus, the current operational storage volume is 0.60 MG (2.20 MG minus 1.60 MG).

Storage requirements at the planning horizon will be dependent upon the filter capacity at the planning horizon. The filter capacity at the planning horizon will be expanded to 7,400 gpm. For a four hour period of peak hour demand the tanks will deliver 2.70 MG and will be supplied with 1.8 MG from the filters. Thus, the future required operational storage will be 0.9 MG (2.70 MG minus 1.8 MG).

Fire Storage – This is the volume of water held in residence for the sole purpose of providing an adequate amount of water for firefighting purposes. Fire storage derives directly from fire flow rate and duration, both specified by the local fire protection agency. The Contra Costa Fire Department has specified fire flow requirements of 3,000 gpm for three hour duration in commercial areas and 1,500 gpm for two hour duration for typical residential areas. The larger is selected for providing a fire safety volume in storage, thus the required fire storage volume is 0.54 MG.

Emergency Storage – This is the volume of water held in residence to accommodate demand requirements in the event of prolonged power outages, failures of the supply system or other interruptions in supply. There are no regulatory requirements for emergency storage; however, LSCE recommends that Discovery Bay have at least one maximum-day event in storage. One maximum day demand is currently 8.2 MG and is projected to be 10.2 MG at build out. For systems using groundwater, the underlying aquifer presents the greatest reservoir available and emergency storage can be achieved by providing backup power to the water supply and treatment facilities. Each water treatment plant is currently equipped with a 750 KW diesel generator. The District currently has portable generators capable of supply the existing groundwater wells with emergency power.

Unusable Storage –There is always a portion of the nominal tank volume that goes unused due to the locations of the inlets and outlets. In some cases this is an assumed percentage of the overall nominal storage requirement. For this system, the exact locations of inlets and outlets are known and the actual usable storage volume is known, thus the usable volume of storage is compared to the sum of the storage requirements.

Table 4-1
Current and Future Nominal Storage Requirements
Town of Discovery Bay

	Current	Build Out
Operational Storage	0.60 MG	0.90 MG
Fire Flow Storage	0.54 MG	0.54 MG
Emergency Storage	—	—
Total	1.14 MG	1.44 MG

Note: Emergency storage (8.2 MG currently and 10.2 MG future) are met by equipping wells and treatment plants with emergency power generators.

4.3.2 Adequacy of Storage Capacity

The District currently possesses storage tanks with a combined nominal volume of 2.05 MG. The actual usable volume is approximately 1.90 MG. From Table 4-1, the total storage requirement is 1.14 MG currently and 1.44 MG at the planning horizon. The combined storage of the system can meet the total storage requirements at the planning horizon.

Although general analyses indicates storage capacity is adequate, in the next section, the distribution system model is used to more closely assess the production flows of each individual treatment plant to determine operational and fire storage requirements specific to each treatment plant. As discussed in section 4.4.9 below, the results of this model run and assessment indicates an additional operational storage is needed at the Newport WTP and, therefore, a new storage tank at Newport WTP is recommended and is included in the Chapter 6 CIP.

4.4 Distribution System

Evaluation of the distribution system as part of this Master Plan effort included review of available District mapping; meeting with District personnel to confirm pipe sizes, types, and age in existing and planned developments; and making updates to the current base map of the system. Meetings with District staff were also held to discuss planned future growth and to

identify problematic areas, such as areas of low pressure and areas subject to high or abnormal leakage rates.

A computerized system hydraulic model was then developed to simulate system performance under various customer demands and fire flow scenarios. The results were evaluated relative to the distribution system performance requirements discussed below. The model assisted in developing a plan for mainline replacements and system upgrades to bring the distribution system into compliance with applicable water demand and pressure requirements.

4.4.1 Distribution System Requirements

Distribution system requirements in the California Waterworks Standards (Title 22) requires the operating pressure in the water main at the user service line connection throughout the distribution system to have a minimum pressure of 20 pounds per square inch (psi) at all times including during the peak hour demand and during maximum day flow plus fire flow. The specified fire flow is dictated by the California Fire Code, which requires a minimum flow of 1,500 gpm for houses less than 3,600 square feet, 1,750 gpm for houses between 3,600 and 4,800 square feet, and 3,000 gpm for 3 hours for the typical commercial buildings in Discovery Bay. For fire flows of 3,000 gpm or more, the flow can be met using multiple hydrants.

4.4.2 System Hydraulic Model

The updated base map was used to develop a computer based hydraulic mode of the District's distribution system using the H2ONET software. H2ONET uses the "gradient algorithm" (hybrid method) to solve pipe flow (friction loss) and mass conservation (node balance) equations that characterize a distribution system. The software uses an interface with AutoCAD, making it possible to construct, manipulate, and view model elements in a graphical environment.

The principal benefit of a hydraulic model is that it provides computational and graphical means to identify and assess the strengths and weaknesses of a water supply, storage and distribution system. For the analysis in this Master Plan, system weaknesses were considered to be areas of low pressure during normal, peak, and/or fire-flow demand scenarios.

4.4.3 Model Inputs and Scenarios

The system model is comprised of lines representing distribution mainlines (by size, length and type) and nodes representing points where mainlines connect. Each node is provided an elevation (relative to mean sea level) and can have a water demand (outflow) or water supply (inflow) applied. Water demand consists of customer water demand, fire demand, or a combination of both. Water supply in the Discovery Bay model comes from the two water treatment plants

(Newport WTP and Willow Lake WTP) and each are given a supply pressure to the distribution system. Demands are assigned at nodes based on the number of known service connections and type of service classification (residential, commercial/institutional, or irrigation) along the connected mainlines.

Other inputs to the distribution model include node elevations and pipe roughness factors. Discovery Bay is relatively flat with a variation of about 5 to 15 feet throughout the system, so elevations were not a critical input. Pipe roughness factors are a function of pipe material and condition. The condition of existing distribution piping could not be observed directly so pipe condition was estimated based on the age and material of pipelines, and general knowledge of the water quality (corrosion properties). Using available information, general roughness coefficients (Hazen-Williams) were initially assigned to each pipe as follows: AC pipe - 120, PVC pipe - 130, cast iron pipe - 95, and ductile iron pipe - 95. The factors were then modified as a result of calibration (see Section 4.4.4 Calibration).

The output pressure at the water treatment plants is typically set between 60 psi to 70 psi. Therefore, the model simulations use a pressure setting of 65 psi at both treatment plants. The model is also configured with booster pump curve information, which set an upper limit to the production flow rate from a water treatment plant based on the pressure set point of the plant. The Willow Lake WTP and Newport WTP have a booster capacity of approximately 6,650 gpm and 6,450 gpm respectively, for a combined total capacity of 13,100 gpm at 65 psi.

The model was used to analyze system performance under four demand scenarios:

1. Existing peak hour demand;
2. Existing maximum day demand plus fire flow;
3. Build-out peak hour demand;
4. Build-out maximum day demand plus fire flow.

The simulations of the above scenarios were used to locate any problem areas in the distribution system. A problem area is defined as any location in the distribution system that resulted in pressures below 20 psi.

For maximum day plus fire flow simulations, the required fire flow was applied at a single hydrant while the system is experiencing the MDD flow rate. The simulations were used to determine the available flow rate from each hydrant in the system at a minimum residual pressure of 20 psi. For fire flow simulations, problem areas are where a hydrant has an available flow rate that is less than the required fire flow, i.e. 1,500 gpm for residential and 3,000 gpm for commercial.

4.4.4 Calibration

A standard procedure for model calibration is to compare actual hydrant flow and system pressure to the simulated system flow and pressure. The simulated system flow and pressure is compared to field data as a method of estimating the model's accuracy and, if necessary, parameters (i.e. roughness coefficients) are adjusted as a means of calibrating the model.

Field data was collected in hydrant flow tests conducted by the District and LSCE in January and in March 2011 to calibrate the hydraulic model. The field data consisted of measuring flow and pressure from test hydrants and from the two water treatment plants. Simulations were set up in the model to reflect conditions measured in the field for each test, i.e. measured demands were assigned to the nodes in the model and supply pressures were assigned to the treatment plants. The simulated residual pressures were compared to the measured residual pressures in the system. As a method of calibrating the model, the roughness coefficients (Hazen-William C factors) were adjusted according to pipe materials to refine the simulated flow-pressure response.

When the observed residual pressures in the model were within plus or minus 5 percent of measured residual pressures, the model was considered to be sufficiently calibrated for the purposes of this Master Plan, i.e. for a distribution system of this size and complexity. The following C factors apply to the calibrated model: AC pipe - 110, PVC pipe - 110, cast iron pipe - 75, and ductile iron pipe - 90.

4.4.5 PHD Simulations

The simulations of the PHD (existing and build out) resulted in adequate system pressures. The build-out PHD simulation indicated the minimum residual pressure was 36 psi. This minimum pressure condition was noted in the northeast of the system at the end of Discovery Bay Blvd. A benefit of utilizing a hydraulic model is the ability to visibly identify pressure gradients throughout the system. Plate 2 contains a map of the hydraulic model that shows pressure contours within the distribution system during PHD at build-out.

4.4.6 MDD plus Fire Flow Simulations

The simulations for the MDD plus fire flow resulted in areas that cannot maintain the minimum 20 psi pressure requirements during residential fire flow in the existing system and in the build-out system. The majority of problem areas occur along Cabrillo Point, Discovery Point and Double Point Way where there are long runs of 6-inch mainline with insufficient looping. Some low pressures also occur at the end of long runs of 8-inch mainlines such as Discovery Bay Blvd, Beaver Ct, Beaver Lane, Starboard Drive and Starfish Ct. Other areas that could not achieve fire flows were at the ends of some of the dead end streets that contain 6-inch mainline, such as:

North Pt, South Pt, Surfside Pl, Surfside Ct, Shell Ct, Beach Ct, Wayfarer Ct, Lanai Ct, Marina Cir and Lido Cir. The system can meet the commercial fire flows, although in some cases multiple hydrants were required to meet the minimum flow of 3,000 gpm, such as at the restaurants near the marina.

As previously noted, the residential fire flow is based on a flow rate of 1,500 gpm from a hydrant and a minimum residual pressure of 20 psi in the distribution system. For the problem areas noted above, the hydrants were capable of at least 1,000 gpm at a residual of 20 psi. Plate 3 presents a map of the hydraulic model that shows the available flow rates for each hydrant node in the model at a residual pressure of 20 psi. The flow rates on Plate 3 are color coded - a red color code indicates the available flow is less than 1,500 gpm and cannot meet the fire flow requirement.

4.4.7 Alternatives for Distribution System Improvements

Several alternatives are available to the District to address problems associated with fire flows in the distribution system. Two alternatives were developed in the hydraulic model to bring the system into compliance with performance standards by incrementally increasing pipeline sizes and in some cases adding new mainline crossings. The two alternatives consist of the following: (1) a mainline replacement program that abandons older mainlines and replaces them with larger diameter pipe; and (2) enhance mainline looping by installing new crossings and replace some older mainlines with larger diameter pipe. The alternatives share some common mainline replacements. The alternatives are described below:

Alternative 1 – Mainline Replacement Only (See Figure 4-3)

This alternative provides mainline replacements consisting of the following:

- Install 9,000 linear feet of 16-inch mainline and valves to replace all 8-inch mainline on the entire length of Willow Lake Rd, and some 6-inch mainline on Discovery Bay Blvd between Willow Lake Rd and River Pt.
- Install 15,300 linear feet of 8-inch mainline and valves to replace 6-inch mainline on Cabrillo Pt, Discovery Pt, Double Point Way, North Pt, Lanai Ct, Tamarisk Ct, South Pt, Surfside Pl, Surfside Ct, Shell Ct, Beach Ct, Marina Cir and Lido Cir.

Alternative 2 – Distribution System Looping and Some Mainline Replacements (See Figure 4-4)

This alternative provides mainline looping and some mainline replacements:

- Install two new mainline canal crossings below Kellogg Creek. Each crossing is about 800 linear feet of 16-inch pipe. One crossing connects Discovery Pt to the future Pantages 16-inch mainline. The other crossing connects Cabrillo Pt to the future Pantages 16-inch mainline.
- Install 7,350 linear feet of 16-inch mainline and valves to replace 8-inch mainline on Willow Lake Rd from Beaver Lane south to Discovery Bay Blvd.
- Install 6,400 linear feet of 8-inch mainline and valves to replace 6-inch mainline on South Pt, Surfside Pl, Surfside Ct, Shell Ct, Beach Ct, Marina Cir and Lido Cir.

4.4.8 Alternative Evaluation and Recommendation

Unit costs were developed in order to compare the alternatives for distribution system improvements. The unit costs for pipeline replacements are based on direct experience with improvements of similar nature and size, specialized contractor input, and RS Means' published construction cost data. The table below provides a summary of the costs for each alternative.

Table 4-2
Distribution System Alternative Comparison
(All Costs in Thousands of Dollars)
Town of Discovery Bay

Item	Unit Cost	Alternative 1		Alternative 2	
		Length	Cost	Length	Cost
16-inch Canal Crossings	\$300 / LF	0	\$0	1,600 LF	\$480
16-inch Mainline	\$190 / LF	9,000 LF	\$1,710	7,350 LF	\$1,400
8-inch Mainline	\$75 / LF	15,300 LF	\$1,150	6,400 LF	\$480
Total Cost		\$2,860		\$2,360	

Alternative 2 saves about \$500,000 by reducing the need to replace some 8-inch on Willow Lake Rd and by eliminating the need to replace long runs of 6-inch mainline on Cabrillo Pt, Discovery Pt, Double Point Way, North Pt, Lanai Ct and Tamarisk Ct. The underwater crossings are more expensive than a conventional pipeline project, but it yields greater benefits by reducing much of need for new 8-inch mainline on some smaller streets and indirectly improving system flows in other areas which reduced the need to install some of the 16-inch mainline on Willow Lake Rd. Alternative 2 also includes replacing some older mainlines, which is a benefit for the District to begin doing in stages. Typically, mainlines have reached their serviceable life when leaks and breaks start to become a common occurrence or when performance drastically declines. By beginning the first stages of mainline replacements in this Capital Improvement Plan the District

can get ahead of replacing older mainlines before they reach their serviceable life. Alternative 2 pipeline improvements are recommended to address system performance deficiencies during fire flows and to begin a program that replaces older mainlines in the system.

4.4.9 Model Simulations after Improvements

The recommended distribution system improvements of Alternative 2 were included in the model and simulations were again completed to assess the resulting hydraulics of the system. Plate 4 contains a map of the model that shows pressure contours of the system during PHD at build-out after improvements were made. Plate 5 is a map of the hydraulic model that shows the available hydrant flows in the system after the improvements were made.

The build-out PHD simulation after improvements results in a minimum residual pressure of 48 psi in the system which occurs in Village 5. This is an improvement to the 36 psi observed before improvements were made.

The modeled demand flow rates contributed from each water treatment plant are used to assess operational and fire storage requirements specific to each treatment plant. Since Newport WTP has limited storage relative to the Willow WTP, it is the focus of the discussion herein. The simulation of PHD at build-out resulted in a 5,400 gpm from Newport WTP and the remaining 5,800 gpm from Willow Lake WTP (for a total build-out PHD of 11,200 gpm). At build-out, the Newport WTP would require an operational storage volume of 0.38 MG. A commercial fire flow simulation for the shopping center near Newport WTP resulted in approximately 2,000 gpm of the fire flow coming from Newport WTP. The required fire storage volume at Newport WTP is thus 0.36 MG. The total storage required at Newport (the operational water demand plus the fire flow demand) is 0.74 MG at build-out. Based on a similar review at current service levels, the current operational and fire storage requirement at Newport WTP is 0.51 MG. Currently, the Newport WTP has a total storage of 0.54 MG and can therefore meet the current operational and fire storage requirements at Newport WTP (0.51 MG). In the future, the operational demand will increase and the storage requirements at Newport WTP will exceed its storage capacity. This occurs when the system has approximately 7,085 EDU. Based on the schedule for developments (Chapter 2), the system will reach 7,085 EDU in 2014. Figure 4-2 shows the relationship between tank capacity (in terms of EDU) and the current and build-out EDU.

Two options are available to address the storage deficiency at Newport WTP: (1) provide a new storage tank at Newport WTP that is equally sized as the existing tanks; (2) utilize operational pressure set points to direct more of the peak demands towards Willow Lake WTP, where the storage is ample for operational and fire safety. Implementing the latter option would limit the operational flexibility of the system in the long run and is not recommended as a permanent solution. It is recommended to construct an additional 275,000 gallon storage tank at the

Newport WTP for the operational, fire safety and backwash water supply needs of the treatment plant. This recommendation is included in the CIP presented in Chapter 6.

Continued reliability of the distribution system performance depends on the operation of the booster pumps. It is recommended that the booster pumps be tested frequently to assess the pumps conditions and pump performances to plan for future booster pump upgrades. The CIP also includes provisions to test the booster pumps on a regular schedule.

4.4.10 Existing Pipeline Conditions

The distribution water pipeline condition was evaluated individually by the District operator's records of pipeline repairs, frequency and location of leaks. Flow and pressure measurements also provided an indication of the overall pipeline condition. The District has not experienced a problem with mainline leaks in the system, and areas of low pressure have not been reported. The C factors presented in the calibrated model (see Section 4.4.4) indicate typical roughness coefficients for a distribution system of this age.

As presented in Chapter 3, the age of mainlines in the system range from 10 to about 40 years. Water mains can typically have a serviceable lifespan of 50 to 70 years, but actual service life depends largely on pipe condition and working environment. An indication of a pipeline that has reached its serviceable life is when pipeline leaks become common occurrences or when distribution system performance is compromised from the condition of mainlines. Although the existing distribution system appears to be in adequate condition, the mainline replacement programs presented in this Master Plan will allow the District to get ahead of infrastructure replacements that may be required on a larger scale when older mainlines reach their serviceable life.

While the water mains appear to be in good condition, the District has responded to numerous leaks on the customer service connections. The District reports the majority of leaks occur in the northern region of Discovery Bay Proper. According to the District, the original water system was constructed with polybutylene service connections. Use of polybutylene service connections has declined because over time it has been found to become brittle by continuous contact with chlorinated water. AWWA currently provides a standard (C901) for a polyethylene (PE) water service pipe, which is far superior to the polybutylene tubing, and is now used as the standard for service connections in many water districts. Copper tubing is also used in many places for water services, but there is concern using copper tubing at Discovery Bay due to the aggressive/corrosive soil environment. Because of the history of leaks in service connections, where mainline replacements are recommended the cost includes replacing the service connections along the mainline.

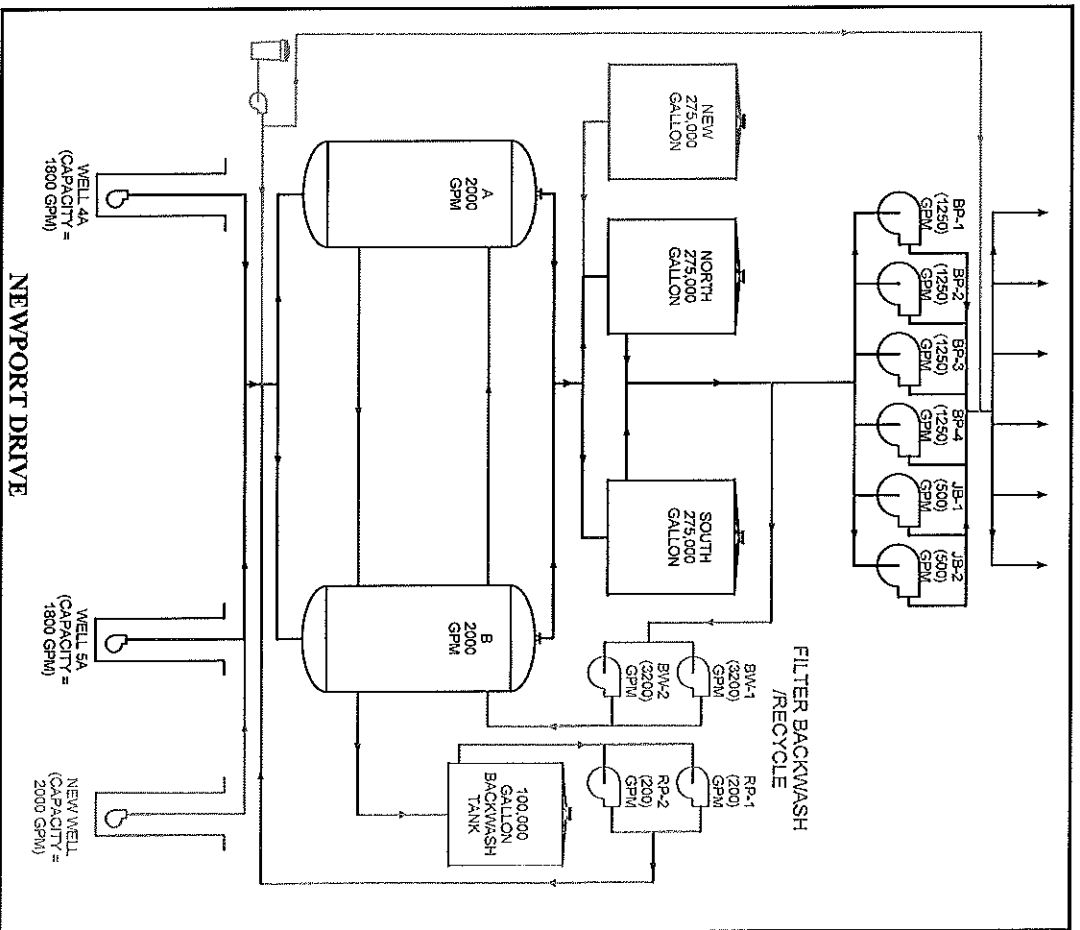
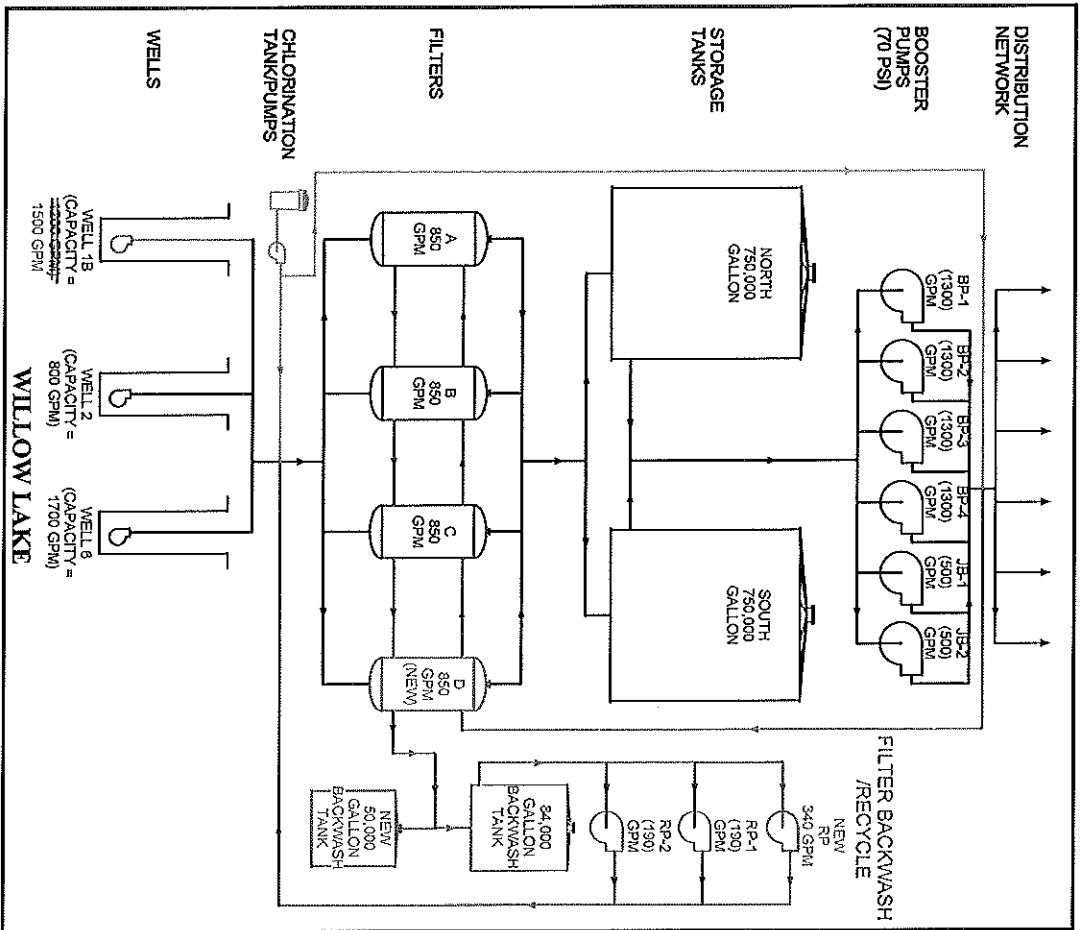

Figure 4-1
Water Supply, Treatment and Storage Schematic
Discovery Bay 2010 Water Master Plan

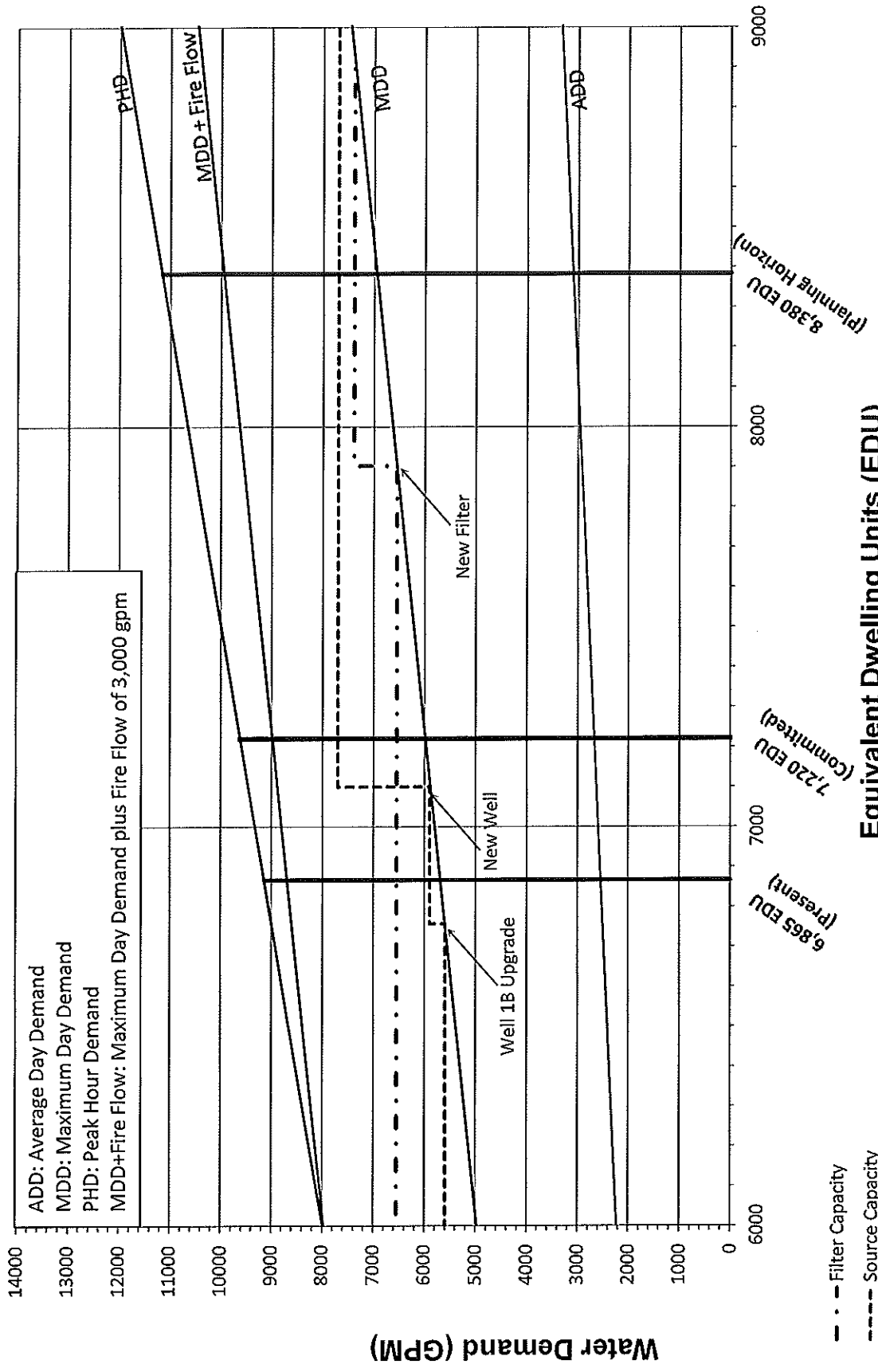
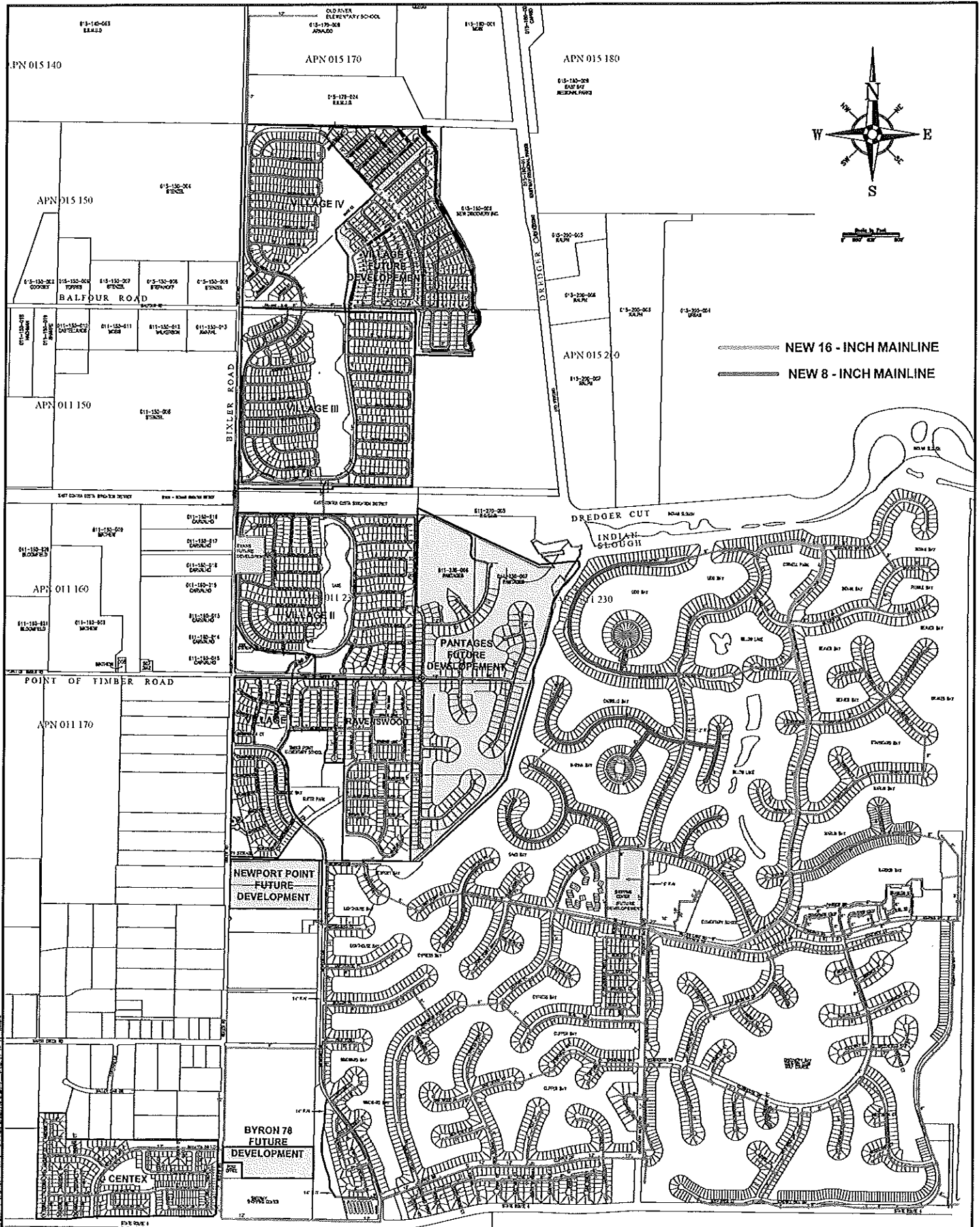
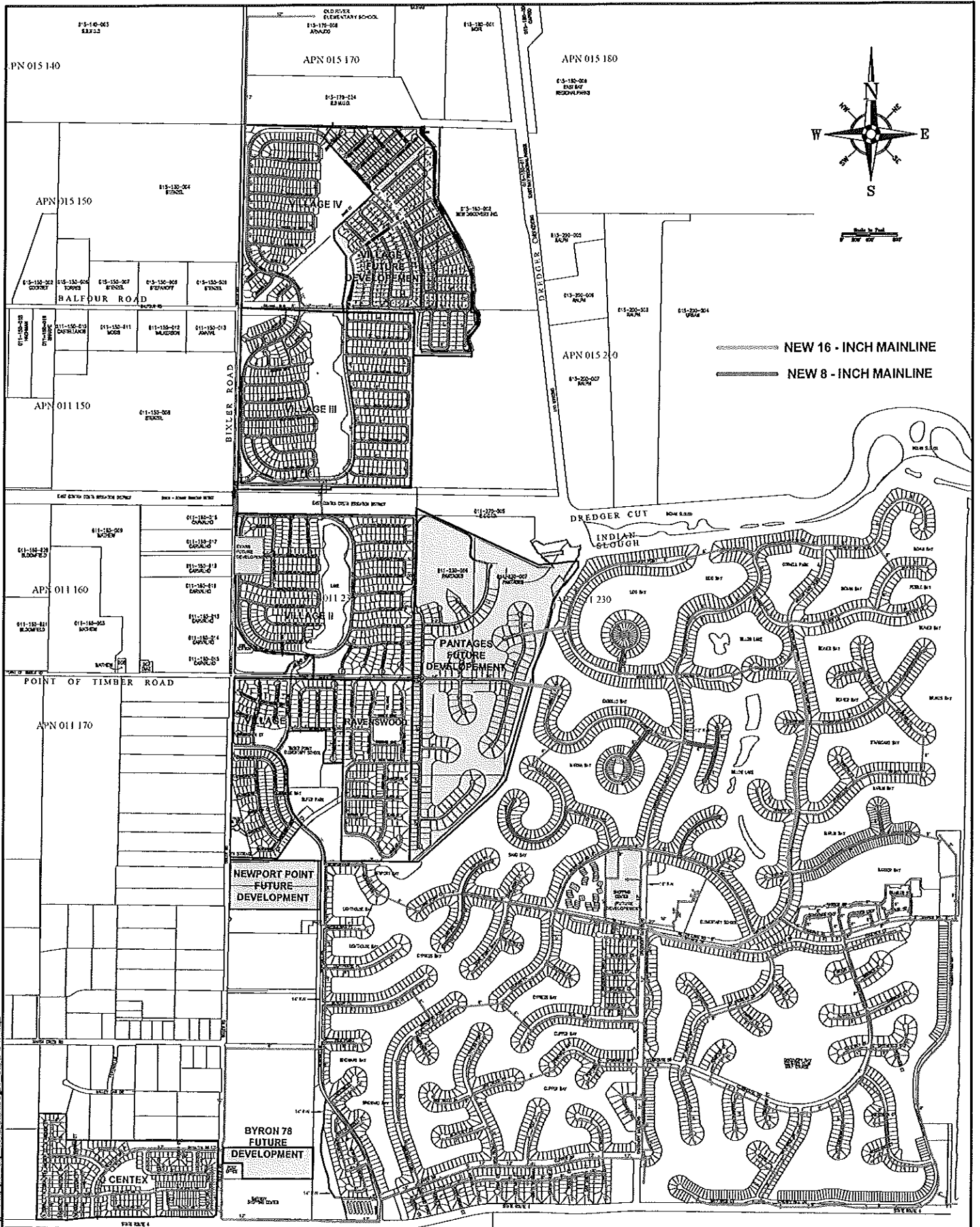

Figure 4-2
Water Supply and Treatment Improvements
Discovery Bay 2010 Water Master Plan





5. Groundwater Basin Assessment

This chapter provides an overview of the geologic and hydrogeologic setting as a foundation for understanding the District's sole source of water supply. Recommendations focus on implementing groundwater monitoring and interpretation while continuing with recently implemented biannual testing of each of the supply wells.

5.1 Geologic Setting and Occurrence of Groundwater

Discovery Bay is located in eastern Contra Costa County in the northwestern San Joaquin River Valley portion of the Great Valley geomorphic province of California. The province is characterized by the low relief valley of the north-flowing San Joaquin River and the south-flowing Sacramento River, which merge in the Delta region just north of the community and then drain westward to the Pacific Ocean.

To the west of Discovery Bay, the adjacent Coast Range province consists of low mountains of highly deformed Mesozoic and Cenozoic marine sedimentary rocks. These thick marine rocks extend eastward below the Great Valley where they are the targets for gas exploration. Overlying the marine rocks is a sequence of late Cenozoic (Miocene, Pliocene, and Pleistocene) non-marine sedimentary deposits. Small areas of surface exposures of these deposits occur along the edge of the Coastal Range. These beds dip moderately to the east and extend below the San Joaquin Valley. In the subsurface, the nature of these deposits is poorly known, but they are believed to be dominated by fine-grained clays, silts, and mudstones with few sand beds. The lower portion of these deposits may be in part equivalent to the Miocene-Pliocene Mehrten Formation along the east side of the Great Valley. The Upper portion of Pliocene and Pleistocene age may be equivalent to the Tulare Formation along the west side of the San Joaquin Valley to the south, and the Tehama Formation of the Sacramento Valley to the north. It is believed these deposits extend from about 400 feet to 1,500-2,000 feet below the San Joaquin River. Water quality from electric logs is difficult to interpret, but the quality appears to become brackish to saline with depth.

Late Cenozoic (Pleistocene and Holocene; 600,000 years to present) sedimentary deposits overlie the older geologic units in the San Joaquin Valley. These deposits are largely unconsolidated beds of gravel, sand, silts, and clays. The deposits thicken eastward from a few tens of feet near the edge of the valley to about 400 feet at the Contra Costa County line. West of Bixler Road, the deposits are characterized by thin sand and gravel bands occurring within brown sandy silty clays and are believed to have formed on an alluvial fan plain fed from small streams off the Coastal Range to the west. The alluvial plain deposits interbed and interfinger with deposits of the fluvial plain to the east. These fluvial deposits consist of thicker, more

laterally extensive sand and gravel beds of stream channel origin interbedded with flood plain deposits of gray to bluish sandy to silty clays. Discovery Bay occurs on the fluvial plain area of eastern Contra Costa County. Groundwater supply in Discovery Bay is extracted for supply purposes from these deposits to a depth of about 350 feet.

The regional geologic setting is best reviewed on the San Francisco-San Jose 1° by 2° quadrangle (Wagner and others, 1990). Detailed surface geologic maps of the Coast range in this area include Davis and Goldman (1958), Brabb and others (1971), and Dibblee (1980 a, b, c). Subsurface characterization of the marine rocks beneath the San Joaquin Valley can be found in oil and gas field summaries produced by the California Division of Oil and Gas (1982), and Thesken and Adams (1995). General geologic descriptions and histories of these marine rocks are contained in Bartow (1991), and Bertoldi and others (1991). Because of their marine origin, highly consolidated nature, and presence of saline water, the Mesozoic and tertiary marine rocks are not a source of potable water supply in the region.

A regional study of the thickness of the Tertiary-Quaternary non-marine sedimentary deposits was made by Page (1974) and evaluations of the depth to base of fresh water by the California State Water Project Authority (1956) and Berkstresser (1973). Regional studies of the Sacramento-San Joaquin Valley groundwater basin were performed by Bertoldi and others (1991), and Page (1986). The United States Geological Survey (USGS) compiled water quality information that covers the area in a series of reports (Keeter 1980; Sorenson 1981; and Fogelman 1982). California Department of Water Resources (DWR, 1967) covers the groundwater resources of the San Joaquin County to the east. Luhdorff and Scalmanini Consulting Engineers (1999) conducted a study of the eastern Contra Costa County area groundwater resources and prepared a groundwater management plan for Diablo Water District (2007). LSCE also conducted a study of groundwater resources pertaining directly to Discovery Bay (1993) and a water master plan (1999).

5.2 Hydrogeologic Setting in Discovery Bay

The hydrogeology of Discovery Bay is illustrated through a cross section depicting water wells that are the source of supply for the water system. The supply wells in Discovery Bay are shown on north-south geologic Cross Section A-A' prepared for this master plan.

The deepest unit encountered in water wells in Discovery Bay is below about 350 feet and represents the uppermost, older non-marine deposits of largely fine-grained silt and clay with thin, fine sand interbeds. Water quality appears to be poor to brackish in this formation.

Pleistocene alluvium comprises the overlying units. This zone is labeled Aquifer A and is composed of generally the thick beds of sand and gravel with a thin clay interbed. These are

probably stream channel deposits of a northward flowing ancestral San Joaquin River. Aquifer A is the main production aquifer completed in all the Discovery Bay supply wells.

Overlying Aquifer A is a thick sequence of grayish to bluish silt and clay with thin inter beds of sand. This unit appears to represent deposition on a floodplain with the main stream channels probably further east. The thin sand appears to represent flood-sprays of sand spread out on to the flood plain.

Another aquifer unit, labeled Aquifer B, occurs above about 140 feet below ground surface and consists of a thinner sand and gravel bed. Again, these appear to be stream channel deposits. However, Aquifer B has been found to contain brackish to saline water, which needs to be sealed off from the deeper Aquifer A to protect water quality and to avoid corrosion of the well casing.

Overlying Aquifer B is a sequence of gray to brown silt and clay beds with some thin sand beds. These beds appear to be either floodplain deposits or possibly distal alluvial plain deposits from the west.

5.3 Groundwater Conditions

Groundwater conditions that are relevant to the Discovery Bay water system are discussed below in terms of water levels and water quality.

Groundwater Levels

Groundwater level data are limited as there has yet been a systematic monitoring program implemented by Discovery Bay. A hydrograph of available water levels measured in the supply wells suggest that static water levels are lower than observed in the early 1990s and 2000s. However the most recent levels are likely influenced by a statewide drought and there is insufficient data or historic baseline to indicate whether current levels of pumping represent an adverse trend. Besides the possible influence of drought, groundwater level observations indicate seasonal fluctuations that should be better quantified. An understanding of climatic and seasonal fluctuations would then enable interpretation of groundwater conditions that are of importance to the long-term viability of Discovery Bay's source of supply. All the CIP items under Section 3.4.5, Groundwater Basin Management, are designed to address this current deficiency in groundwater monitoring.

Groundwater Quality

Groundwater quality from Discovery Bay supply wells meets all California Department of Public Health (CDPH) primary drinking water standards. The groundwater does not meet secondary standards for manganese and exceeds the drinking water maximum contaminant limit (MCL) of 0.050 mg/L for that constituent. With manganese removal treatment instituted since the last master plan in 1999, manganese has been eliminated as a water quality issue.

Historically, there were some customer complaints for odor that may have been due to well design and patterns of usage that are no longer relevant to operations. In the past two years, there have been complaints regarding color that are presently being investigated.

Overall, the groundwater is hard and high in total dissolved solids (TDS) concentration, but it does not exceed the upper MCL (1,000 ppm) for TDS. Because of the depth of the primary aquifer (see Aquifer A in Cross Section A-A') and intervening clay layers, source protection is achievable with appropriate seals that are part of the well structure. As a result, none of the wells have exhibited anthropogenic sources of contamination such as volatile or semi-volatile organic contaminants that are often found in urbanized settings. Water quality for each well is presented in an appendix.

The most important water quality concern for the well sources in Discovery Bay is the brackish to saline water that occurs in Aquifer B overlying the main completion targets of the supply wells (see Cross Section A-A'). From measurements in selectively completed monitoring piezometers at the Well 4 site, there is a gradient for flow from this shallow aquifer to the main supply source (i.e., from Aquifer B to Aquifer A in Cross Section A-A'). If a pathway exists, such as via an unsealed wellbore, cross-contamination between the shallow and deeper aquifers can occur.

Historic wells in Discovery Bay experienced failure due to improper isolation, or sealing, of the wellbores that penetrated the saline Aquifer B. This led to rapid corrosion of well casings and cross-contamination of the drinking water source by saline water. Today, only Well 5A exhibits some evidence that cross-flow may be occurring, albeit to a small degree. Testing and evaluation are being conducted to remediate the problem in this well. The appendix shows historical test results for TDS and electrical conductivity (Ec) in the Discovery Bay supply wells.

The recent construction of Well 6 included deeper exploration below the main supply source (Aquifer A). While the groundwater contained in aquifer materials below Aquifer A would be classified as fresh, it was higher in total dissolved solids and the zone was not completed in the production well. The higher TDS encountered in that zone is consistent with the characterization of the hydrogeologic setting as described above.

5.4 Well Yields and Aquifer Characteristics

The specific capacities of the Discovery Bay wells vary from less than 10 to over 30 gallons per minute per foot of drawdown (gpm/ft). At these magnitudes, the Discovery Bay supply wells can be equipped to pump at capacities up to 2,000 gpm. Historic testing indicate that the primary production aquifer has a transmissivity ranging from about 50,000 to 100,000 gallons per day per foot and a storativity that is representative of a confined system. Aquifer parameter estimates

provide a basis for evaluating well performance and appropriate spacing of future wells to minimize mutual pumping interference.

Proper maintenance and early identification of degradation in well yields are important activities for a system that relies entirely on well water as a source. In 2007, Discovery Bay instituted a biannual program to test the well facilities, which included quantification of specific capacity. Through this program, specific capacity testing can be used to schedule rehabilitation programs and identify signs of structural problems. Each testing event is documented with a report discussing changes since the last reporting period and recommendations for preventative or remedial work to sustain source capacity. Since structural problems may be forewarned by increasing salinity (i.e., because of the presence of shallow brackish water), water quality testing is an integral part of the biannual testing.

5.5 Groundwater Basin Yield and Monitoring

Discovery Bay overlies the northwestern portion of the Tracy Subbasin, which is one of sixteen subbasins in the San Joaquin Valley Groundwater Basin as designated by the California Department of Water Resources (DWR 2004 and 2004). The Tracy Subbasin boundaries are defined by the Mokelumne and San Joaquin Rivers on the north; the San Joaquin River on the east; and the San Joaquin-Stanislaus County line on the south. The western subbasin boundary is defined by the contact between the unconsolidated sedimentary deposits and the rocks of the Diablo Range (DWR, 2004).

The reliability of future groundwater supply for Discovery Bay is based on an assumption that the yield of groundwater system is sufficient to sustain current and future pumping. As was the case in the 1999 Water Master Plan, there has been limited groundwater data and analysis on which to assess the long-term impacts of historic and future estimated groundwater pumping. Based on available groundwater monitoring data from the Discovery Bay water supply wells, static water levels are lower than the early 1990s and 2000s. However, as indicated above, the recent lower levels are likely influenced by the statewide drought of 2007-10 and there is insufficient data or historic baseline to indicate whether current levels of pumping represent adverse localized or regional conditions.

Since sustainability also refers to water quality, it is germane to note that groundwater characteristics have been stable in the Discovery Bay supply wells, with one exception. This indicates generally that pumping has been sustainable with respect to quality with no degradation processes evident to the extent that monitoring has been conducted. The exception is Well 5A, which has experienced an increase in TDS due to a well structure problem, not an aquifer problem.

As noted above, there are observed seasonal and climatic fluctuations in groundwater levels evident from the limited monitoring data in Discovery Bay. Since the community is on the fringe of a larger groundwater basin, there are no regional sources or studies that aid in assessing local conditions and whether pumping has caused, or may in the future cause, adverse impacts. While the working assumption is that no significant adverse conditions have arisen since the last water master plan prepared in 1999, it is particularly important under the current planning cycle to implement a systematic program to assess basin conditions and assure that pumping does not exceed the basin yield. Possible consequences of exceeding the basin yield are permanently declining water levels and the potential for intrusion of poorer quality water, if present, from the Delta region as well as downward movement, or cross flow, from shallow brackish aquifers. While there are insufficient data to draw conclusions, at present, on any of these issues, it is very important that the recommendations in the current CIP be implemented to assure that the supply source remains viable through an assessment of basin yield, groundwater fluctuations associated with pumping, and water quality characterization.

It is more appropriate and timely now than in 1999 to implement long-term management of groundwater within Discovery Bay with the principal objective to maintain the availability of local groundwater in sufficient quantity and acceptable quality and to identify changes in supply conditions in a timely manner. Proactive actions include identifying future well sites to serve as replacement sources, participation in local and regional water resource planning, and implementation of current CIP recommendations for monitoring. The latter might include augmentation of groundwater supplies under certain hydrologic conditions (wet years) if supplemental water is available and determined to be effective for groundwater storage or quality by reducing pumping during such times. With respect to local actions, CIP recommendations are made in Chapter 6 to ensure that a proper basis is established on which to judge the sustainability of the water system supply.

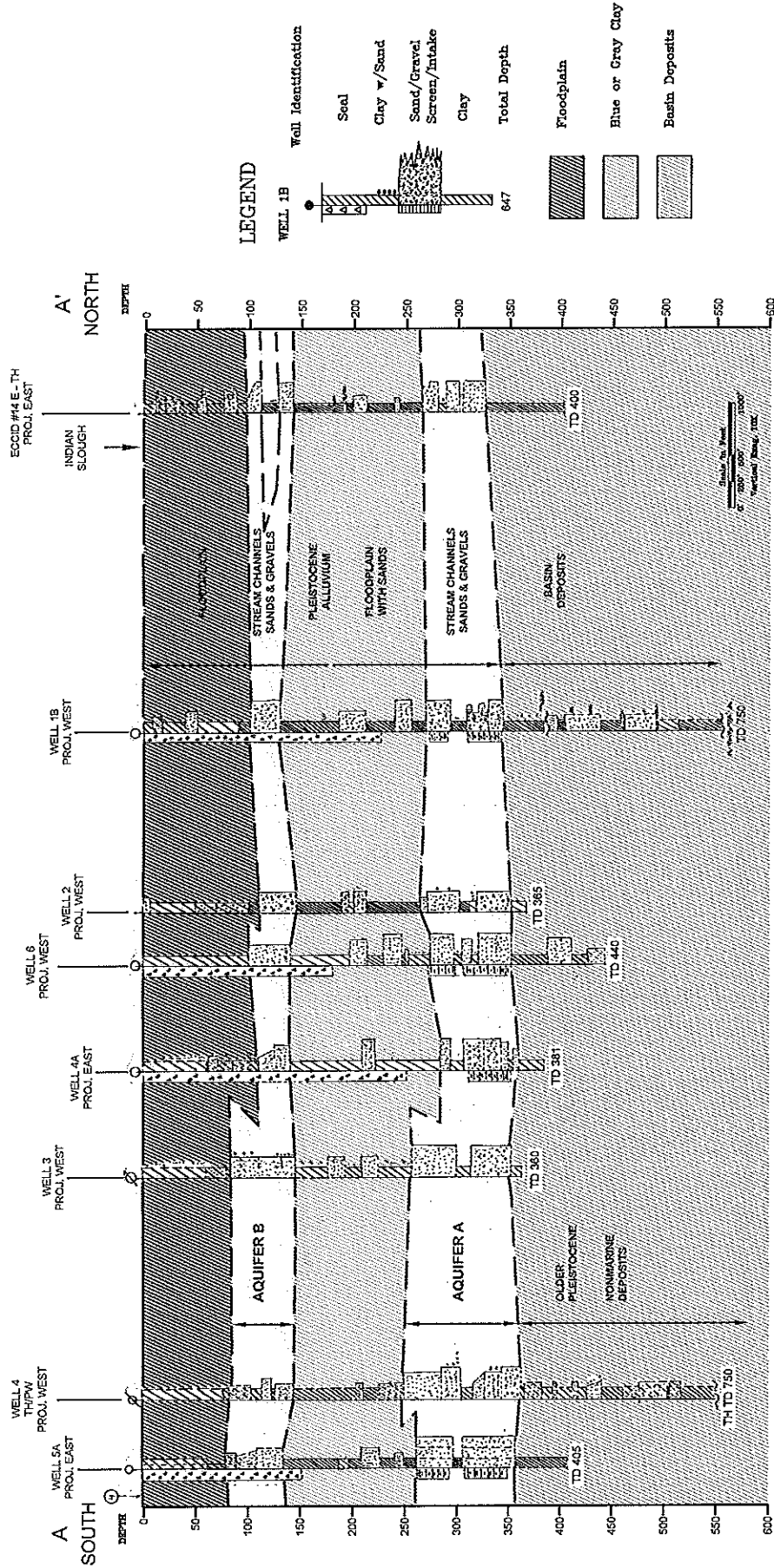
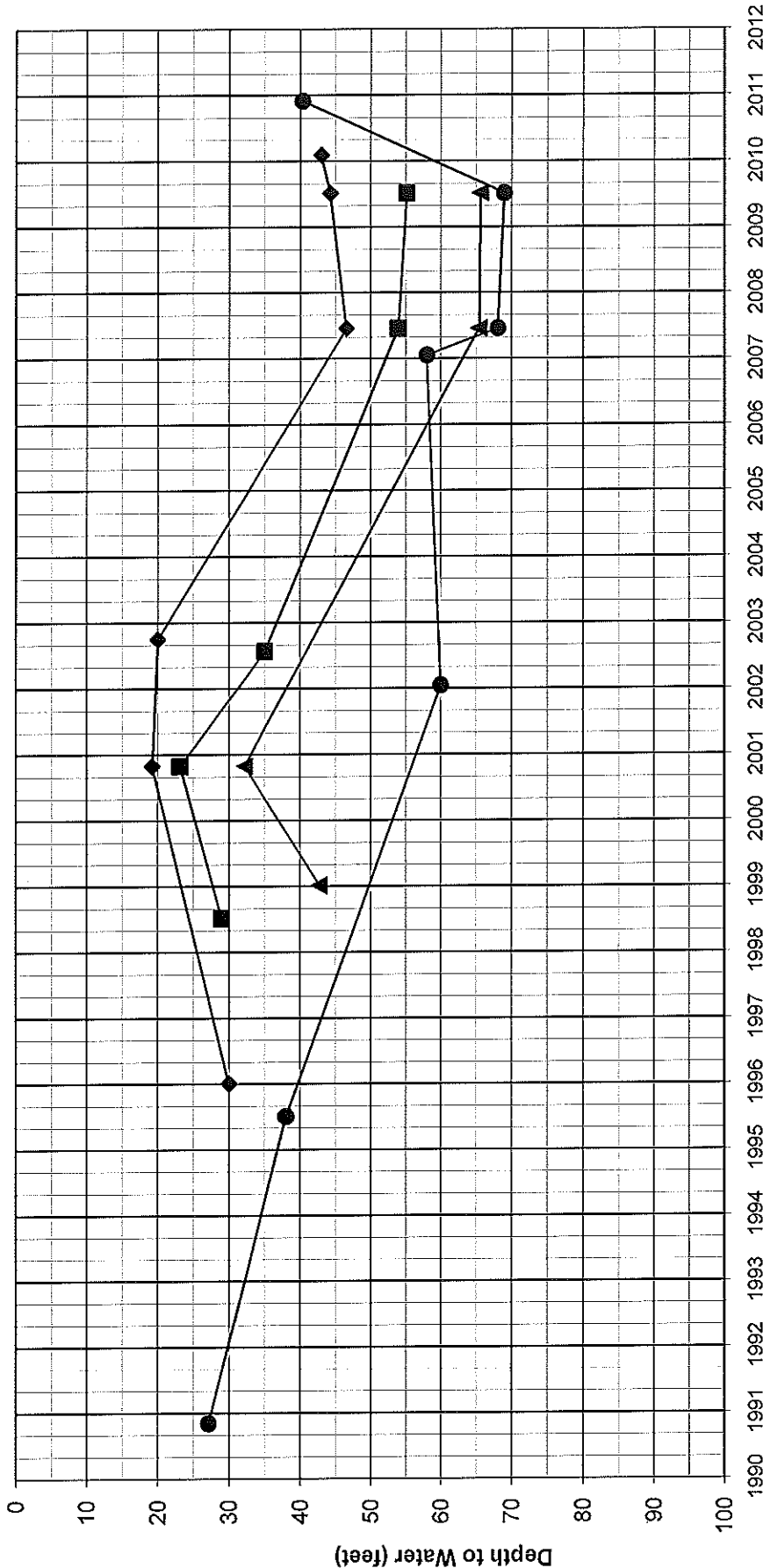

Figure S-1
Geologic Cross Section
Discovery Bay 2010 Water Master Plan



X:\2010 Job Files\10-070\TE Workfile for Hydrogeology\Background\Spec Chap and Hydrograph Nov 09 & Dec 07.xls Hydrograph



**LUJDORFF & SCALMANINI
CONSULTING ENGINEERS**

Date

**Figure 5-2
Hydrograph for Supply Wells
Discovery Bay 2010 Water Master Plan**

6. Capital Improvement Plan

6.1 Overview

The Capital Improvement Plan (CIP) presented in this chapter is a result of the overall assessment of the Discovery Bay water supply, treatment, distribution and storage system. The CIP is intended to provide the District with a guidance document for improving its supply capacity, enhancing treatment facilities, improving the conveyance infrastructure, and adding of other modifications to bring the system into conformance with current regulatory standards and good engineering/operating practices.

The CIP provides recommendations for correcting system deficiencies and improving system operation, a schedule to address the implementation of recommended improvements, and cost estimates for all improvements. The cost estimates include sufficient detail to show the major components of improvements. All costs are expressed in current day costs, with no adjustment for inflation, and include costs for engineering, construction inspection/administration, and contingencies.

Table 6-1 (below) presents the CIP items cost and implementation schedule. Plate 6 of this report contains a location map of all CIP items.

6.2 Prioritization and Schedule for Improvements

An important consideration relative to the Capital Improvement Plan details is recognition that the system modifications presented in this CIP report were developed based upon a combination of factors including the need to comply with regulatory standards (i.e. DPH, Flood Control regulations, RWQCB, F&G, Fire Code etc); the need to adhere to good engineering/operational practices; and to solve operational problems. However, it is practically impossible to budget, design, undertake and complete all those modifications and improvements more-or-less immediately, i.e., in the first one to three years of a Capital Improvement Plan. Consequently, a significant component of the Capital Improvement Plan was to derive suitable prioritization that could be used to assess, rank, and temporally distribute the water system improvements over a selected ten-year time frame to accommodate expected growth as well as budgeting and achievable project implementation.

The principal concerns and objectives governing the prioritization of the various improvements, in decreasing priority relative to each other, were: 1) provision of adequate source supply to ensure that the water system can meet regulated levels of service for the existing system and the

planned developments; 2) improvement of treatment plant capacity and storage capacity to ensure that adequate treated water can be conveyed during periods of high demand for projected growth; 3) replacement of undersized mainlines and additional mainline looping to enhance system flows and pressures during fire flows; 4) provisions for testing and monitoring of equipment performance, well performance, groundwater basin trends in quality and quantity, maintenance of critical equipment and corrosion control; 5) installation of customer meters and measurement of water deliveries to comply with state legislature deadlines; and 6) contingencies for a replacement water supply well to ensure reliability of the source capacity.

The priority criteria discussed above were adjusted to reflect projects that could be connected with scheduled developments, including expanding source supply and treatment capacity required to meet scheduled developments, and the installation of mainline lake/lagoon crossings that coincide with the future Pantages development. Another adjustment to the above priority criteria accounts for CIP items that are on recommended schedules (quarterly, yearly etc), including equipment testing and basin monitoring. Finally, adjustments were made to the above priority criteria to reflect CIP items that could be completed in incremental portions to spread the costs over the period. For example, per the regulations, customer water meters must be installed by 2020. The level of effort and cost to install customer flow meters is significant, and therefore the CIP spreads the cost and work over a two year period that end in 2019. It should be noted that the CIP has some flexibility. For example, if it turns out that a replacement water supply well is needed earlier in the plan, it may be more cost effective to move the pipeline replacements later in the schedule.

6.3 Unit Costs and Projected CIP

The capital costs developed for the Capital Improvement Plan in this Master Plan are primarily derived from unit costs for such items as pipeline replacements based on direct experience with improvements of similar nature and size, specialized contractor input, and RS Means' published construction cost data. Similarly, costs for modifications at facilities such as wells, the water treatment plant, and the installation of monitoring equipment and customer meters are derived from unit costs of components based on direct experience with facilities of similar nature and size, as well as input from specialty equipment manufacturers and/or suppliers.

All the costs reflected in the Capital Improvement Plan are the result of using the unit and/or component, and then adding a 20 percent contingency for unforeseen details that may be encountered on a site-specific basis at the time of detailed design and construction. An additional 20 percent of the base estimate plus contingency was then added for a combination of engineering design, construction inspection, and administration. All the Capital Improvement Plan costs are expressed in 2011 dollars; no assumed inflation has been factored into the costs for system modifications in succeeding years of the Master Plan period, i.e., through 2020/2021.

6.4 CIP Items

The CIP is divided into improvement types or categories presented below in terms of water source development, water treatment plant upgrades, water distribution system modifications, storage tank units, groundwater basin management activities, customer water meters installations, and corrosion protection. Several CIP items are presented for each type or category of improvement.

6.4.1 Source Capacity

The CIP items associated with water source supply include the addition of a new production well, contingency for a future well replacement and regularly scheduled well and well pump testing and maintenance.

CIP Item 1a- New Supply Well: The new supply well (Well 7) is needed for source capacity to meet the maximum day demand with the largest well offline. The source capacity is currently deficient by 100 gpm and will be deficient by 1,400 gpm at build-out. The projected development schedule shows new homes being completed in 2013; therefore, the new well is immediately needed. The new well will be dedicated to the Newport WTP and target a flow rate of 2,000 gpm to match filter unit capacities. This CIP is separate into three phases over the first three years of the CIP. Phase 1 includes locating a suitable well site, preparing a CEQA document, preparing a base map and a conceptual design. Phase 2 includes designing the well, well construction and preliminary design of the pump station and raw water pipeline. Phase 3 includes finalizing pump station/pipeline design, construction of the facilities and obtaining a CDPH water supply permit amendment.

CIP Item 1b and 1c- Replacement Well Site and Well Abandonment Contingency: A well site contingency is included in the CIP to ensure source capacity can continue meeting the required levels of service. Although a replacement well is not immediately needed it is reasonable to assume that one of the existing wells will need to be replaced within the 10-year plan. CIP Item 1b is to install a new water supply well to replace an existing well in the event of failure. This includes acquiring a new well site and building a new pump station and raw water line to the treatment plant. This contingency is placed at the end of the 10-year plan; however, it could be used sooner if needed. CIP Item 1c is for destruction of the well structure upon completion of a replacement water supply well and pumping facility.

CIP Item 1d- Well 1B Pump Upgrade: Provide a new submersible well pump for Well 1B. Utilize the existing 150 horsepower motor and select a pump that maximizes flow rate subject to

the 150 horsepower limitation. The pump upgrade is placed in the beginning of the CIP schedule in order to address current water supply shortfalls.

6.4.2 Treatment Facilities

The CIP items associated with treatment include provisions to expand treatment capacity to meet the increased treatment and backwash requirements of projected growth. The CIP also includes upgrading the electrical and mechanical portions of the chemical room at the Willow Lake WTP to allow all well pumps to be operated simultaneously. Other CIP items include contingency for recycle pump upgrades at Newport WTP, filter media replacement, booster pump upgrades at both treatment plants, and regular maintenance and inspection of the booster pumps.

CIP Item 2a- Treatment Filter Unit at Willow Lake WTP: A new filter unit is required at the Willow Lake WTP to meet future levels of service. The new filter (Filter D) will have a capacity of 850 gpm to match the other three filters located at the treatment plant. The work will include a new filter vessel and filter media, extension of the existing concrete foundation, and installation of new face piping and valves for all four filter units. The current filter capacity of the system can provide water during maximum day demand for up to 7,920 EDU, which the system will reach in 2016 according to the projected rate of development reflected in Table 2-1 (Chapter 2). To be prepared for future levels of service, the new filter is scheduled for completion in the 2014/2015 fiscal year. The work is concurrent with the other improvements required to increase treatment capacity (see associated CIP Items 2b and 2c below).

CIP Item 2b- New Backwash Tank at Willow Lake WTP: An additional backwash tank at the Willow Lake WTP is required for the addition of the fourth filter. The new backwash tank will have a capacity of 50,000 gallons to provide the additional volume needed for backwashing four filters during high demands. The cost also includes a foundation, underground piping, and valves to connect the tank to the existing backwash tank.

CIP Item 2c- New Recycle Pumps at Willow Lake WTP: The recycle pumps are regulated at 10-percent treatment flow. The recycle pumps at Willow Lake WTP require upgrades to increase their capacity based on the increase in filter capacity. The work includes installing three new recycle pumps, station piping and control valves that connect the two backwash tanks to the raw water line. The two existing recycle pumps will be removed. The recycle pumps are scheduled to occur at the same time as the new backwash tank installation and the new filter installation.

CIP Item 2f- Chemical Room Upgrade at Willow Lake WTP: An upgrade of the chemical room at the Willow Lake WTP is needed to provide chemical treatment for all three well pumps simultaneously, which will be needed at future levels of service. Currently, there are three metering pumps in the chemical room, but electrical circuitry limits operation to two. The

chemical room upgrade will include electrical wiring for the metering pumps to the PLC controls. The upgrade will also include replacing the corroded process tubing and installation of stainless steel shelves mounted on the walls for the metering pumps.

CIP Item 2e- Recycle Pump Upgrade Contingency at Newport Drive WTP: A contingency is made for replacement of the Newport WTP recycle pumps. No change in capacity is required. Although the recycle pumps are currently operating adequately, replacement is scheduled for the 2016/2017 fiscal year based on a typical serviceable life for these types of pumps in this type of application (i.e. about 15 years).

CIP Item 2f- Booster Pump Upgrade: Upgrade and maintenance of the existing booster pumps is included in the CIP. Maintenance can include shop work on motors and pumps that have declined in performance or replacement of motors and pumps that are un-repairable. The District is currently replacing a booster pump at the Newport WTP and additional replacements may be necessary upon inspection.

6.4.3 Distribution System

The CIP items associated with the distribution mainlines include work needed to improve the performance of the distribution system during fire flows. The model simulations of the distribution system indicate there are portions of the system in Discovery Bay Proper that cannot meet the current fire flow requirements. To improve distribution performance the CIP includes two new mainlines that cross beneath Kellogg Creek to connect the future Pantages to Discovery Bay Proper, and replacement of smaller diameter mainlines in other areas. The mainline replacements will also benefit the District by removing portions of the older pipelines.

CIP Item 3a- Kellogg Creek Mainline Crossings: This item is for two new mainlines that cross beneath Kellogg Creek to connect Discovery Bay Proper to Pantages. Each pipe crossing will be constructed of 16-inch HDPE and will be approximately 800 feet long to account for a future widening of Kellogg Creek (Reclamation District 800). One crossing connects the existing 6-inch on Cabrillo Point to the future 16-inch on Point of Timber Rd, and the other crossing connects the existing 6-inch on Discovery Point to the future 16-inch off of Point of Timber Rd. The Pantages distribution mainlines have not yet been constructed. The schedule for the Kellogg Creek crossings is based on the Pantages development completion by 2018, as reflected in Table 2-1 (Chapter 2). The costs for the creek crossings were obtained based upon preliminary review of the area and discussions with horizontal boring contractors, Reclamation District 800 and their engineer.

CIP Item 3b- Replace some 8-inch Mainline on Willow Lake Rd: This item is to install 16-inch mainline on Willow Lake Rd to replace 7,350 feet of existing 8-inch mainline. The new 16-inch

mainline will go from Beaver Lane and south to Discovery Bay Blvd (near the treatment plant). This will improve system performance while also remove some older mainlines and replacing them with new C905 pipe that has a minimum 50-year life. The work is separated evenly across 2 years because of the amount and cost for this much mainline replacement. The work is scheduled in the middle of the CIP (2015/2016 and 2016/2017 fiscal years) to allow immediate needs for water supply and treatment to take precedence.

CIP Item 3c through 3j- Replace 6 Inch Mainlines on various streets: Replace 6-inch mainlines with new 8-inch C-900 pipe on the following streets: Surfside Ct, Surfside Pl, Marina Cir (entry way only), Lido Cir (entry way only), Beach Ct, Shell Ct, Edgeview Ct and South Pt. This will address fire flow capacity deficiencies identified on the above noted streets. Because of the expense of installing this much mainline at one time, the work is separated into groups of streets per year near the end of the CIP schedule. Prior to conducting this work, the District should meet with the fire department and test the hydrants to field verify the pipe diameters and locations used in the hydraulic model.

6.4.4 Storage Facilities

The storage reservoirs at Discovery Bay are required to equalize supply and demand over periods of high consumer demand and to maintain a reserve for the sole purpose of fire safety. Each individual water treatment plant has a storage requirement that is based on the plant's production flows and its well supply capacity to replenish the tanks. The CIP includes a new storage tank at the Newport WTP to address storage deficiencies at projected service levels. The CIP also includes regular maintenance of the existing standby generators that are used to power the water treatment plants and wells sites to satisfy the emergency storage requirement.

CIP Item 4a- New Water Storage Tank at Newport WTP: Furnish and install a 275,000-gallon storage tank at the Newport WTP. The current storage capacity can provide the operational and fire safety needs for up to 7,085 EDU. The system will reach that size in 2014 according to the rate of development reflected in Table 2-1 (Chapter 2). The work is shown in the CIP beginning in the 2013/2014 fiscal year with a completion in the 2014/2015 fiscal year. An earlier completion is not expected due to immediate efforts and funding requirements on a new water supply well (see CIP Item 1a).

6.4.5 Groundwater Basin Management

The entire domestic water supply for Discovery Bay is developed from groundwater underlying the site. Since the initial exploration efforts to investigate on-site ground water as a potential water supply in 1967, followed by construction of the first water supply Wells 1 and 2 in 1971, the subsequent development of ground water at Wells 3 through 5, (replacement of Wells 1, 4, and 5), and the recent addition of Well 6 (2010), the available information suggest the aquifer

system beneath the site contains sufficient quantity and quality groundwater to meet the water requirements of the system. Historically, however, there has been very limited investigation or data collection regarding ground-water conditions and water requirements at Discovery Bay. Chapter 5 included a discussion of the regional ground-water setting and considerations for ongoing monitoring and management of ground-water resources as the sole supply for existing and future water requirements. There are several CIP items that have been identified to acquire the necessary information to demonstrate that there is sufficient water available to meet the future water requirements of the project. The CIP improvements include Items 5a through 5d below.

CIP Item 5a- Install Transducers: Install permanent transducers and data loggers to automate groundwater level monitoring.

CIP Item 5b- Install Monitoring Wells: Install shallow monitoring wells to expand the multi-aquifer water level and water quality monitoring network to assess the potential for cross flow between Aquifer A and B.

CIP Item 5c- Survey Wellheads: Conduct wellhead surveying of all wellheads to establish reference point elevations and a common datum for all water level measurements.

CIP Item 5d- Groundwater Basin Assessment: Conduct a formal groundwater basin assessment that includes the following tasks and objectives:

1. Identify other nearby wells to serve in local groundwater characterization and monitoring.
2. Conduct quarterly static water level surveys and assess seasonal and longer-term changes to identify the direction of groundwater flow and to interpret the general direction of recharge to the aquifer.
3. Design and conduct aquifer testing at selected locations, with multi-aquifer monitoring, to further analyze the extent of the primary production aquifer and inter-aquifer groundwater movement.
4. Estimate perennial yield of aquifer system based on available historical data and refined as appropriate by accumulated monitoring data.

6.4.6 Water Conservation and Water Demand Management

As discussed in Chapter 2 the California Assembly Bill 2572 (AB 2572) requires that all urban water suppliers, such as the Discovery Bay CSD, install water meters on all municipal and industrial water service connections by January 1, 2025. Subsequent legislation indicates that the

deadline will be moved to 2020. Therefore, the CIP (see *CIP Item 6a below*) covers the cost to install customer water meters on all unmetered connections by 2019 (all new connections from developers have to be installed with customer meters). In addition, in order to be eligible for state water grants and loans, another Senate Bill X 7-7 (*Water Conservation Bill of 2009*), establishes the goal to reduce statewide per capita urban water use by 20 percent by the year 2020. The District views the conservation of water to be an important component of ensuring the sustainability of their groundwater resource and realizes there may be a potential cost savings associated with not having to engineer and construct water infrastructure (wells, treatment units, storage tanks, distribution system pipeline), often linked to the ever increasing demand for water. Therefore, the CIP (see *CIP Item 6b below*) covers the cost for preparing a water conservation feasibility evaluation that will include an assessment of the potential water conservation measures including the amount of water that could be saved for each measure and the planning-level cost to implement.

CIP Item 6a- Customer Water Meter Installations: Furnish and install 3,907 customer water meters by 2019. Because of the expense to install all meters at one time, the work is separated across two years ending on the 2018/2019 fiscal year to meet a deadline of 2020.

CIP Item 6b- Water Conservation Program: Conduct a feasibility evaluation for developing and implementing a Water Conservation Program. The evaluation will include a basis for water conservation and demand management goals, feasible conservation measures, and preliminary costs and benefits for meeting the water reduction goals (see Chapter 2).

**Table 6-1
Water System Improvements
Capital Improvement Plan - Fiscal Years 2011 / 2012 through 2020 / 2021
Town of Discovery Bay Community Services District**

ID	CIP Item Descriptions	Unit Costs and Quantity		CIP Cost Estimates				CIP Annual Programs (Not Adjusted for Inflation) ¹										
		Units	Total Units	Unit Cost	Const. Cost	Const. Contingency	Const. Emer / Admin Cost ²	Total CIP Cost	2011 / 2012	2012 / 2013	2013 / 2014	2014 / 2015	2015 / 2016	2016 / 2017	2017 / 2018	2018 / 2019	2019 / 2020	2020 / 2021
Source Capacity																		
a I	New Supply Well (Phase 1) - site location, CIOA, base map and conceptual design	LS	1	\$33,000			N/A	\$7,000	\$40,000	\$40,000								
a II	New Supply Well (Phase 2) - well design and construction, pump station preliminary design	LS	1	\$425,000			\$85,000	\$102,000	\$512,000									
a III	New Supply Well (Phase 3) - pump station/pipe design and construction, CDPH permit amendment	LS	1	\$600,000			\$120,000	\$144,000	\$744,000									
b	Replacement Well Site Contingency - includes site purchase, well, pump station and new water line	LS	1	\$1,050,000			\$210,000	\$252,000	\$1,302,000									\$756,000
c	Well Abandonment/Decontamination Contingency	LS	1	\$75,000			\$15,000	\$18,000	\$93,000									\$108,000
d	Well 18 Pump Equipment Upgrade	LS	1	\$20,000			N/A	N/A	\$20,000									
Treatment Facilities																		
a	Treatment Filter Unit at Willow Lake WTP - include vessel, media, foundation, all new line piping and control	LS	1	\$150,000			\$30,000	\$45,000	\$185,000									
b	New Backwash Tank at Willow Lake WTP - includes piping, modifications and foundation	LS	1	\$250,000			\$50,000	\$60,000	\$310,000									
c	New Reverse Pumps at Willow Lake WTP - includes three pumps, piping and control valves	LS	1	\$50,000			\$10,000	\$12,000	\$62,000									
d	Chemical Room Upgrade at Willow Lake WTP - includes electrical and mechanical upgrades	LS	1	\$20,000			\$4,000	\$4,800	\$24,800									
e	Reverse Pump Upgrade Contingency at Newport WTP	LS	1	\$20,000			\$4,000	\$4,800	\$24,800									
f	Reverse Pump Repair and Upgrade at Newport WTP	LS	1	\$20,000			N/A	N/A	\$20,000									
Water Distribution System																		
a I	Killing Creek Crossing, 16-inch mainline from Discovery Pt to Point of Timber Rd	LF	800	\$300			\$48,000	\$57,600	\$105,600									
a II	Killing Creek Crossing, 16-inch mainline from Cabrillo Pt to Point of Timber Rd	LF	800	\$300			\$48,000	\$57,600	\$105,600									
b	Replace catch mainline with new 16-inch C905 - Willow Lake Rd from Discovery Bay Blvd to Beaver Ln	LF	750	\$75			\$1,395,000	\$279,000	\$3,674,000									
c	Replace catch mainline with new 16-inch C905 - Starfield Ct	LF	830	\$75			\$62,250	\$12,450	\$74,700									
d	Replace catch mainline with new 16-inch C909 - Starfield Ct	LF	675	\$75			\$50,625	\$10,125	\$60,750									
e	Replace catch mainline with new 16-inch C909 - Marina Cir entry way	LF	500	\$75			\$37,500	\$7,500	\$45,000									
f	Replace catch mainline with new 16-inch C909 - Lube Cir entry way	LF	400	\$75			\$30,000	\$6,000	\$36,000									
g	Replace catch mainline with new 16-inch C909 - Beach Ct	LF	800	\$75			\$60,000	\$12,000	\$72,000									
h	Replace catch mainline with new 16-inch C909 - Shell Ct	LF	875	\$75			\$65,625	\$13,125	\$78,750									
i	Replace catch mainline with new 16-inch C909 - Edgewater Ct	LF	825	\$75			\$61,875	\$12,375	\$74,250									
j	Replace catch mainline with new 16-inch C909 - South Pt	LF	1530	\$75			\$114,750	\$22,950	\$137,700									
k	Storage Tanks	LS	1	\$750,000			\$150,000	\$180,000	\$930,000									
l	New Water Storage Tank at Newport WTP - include earthwork, foundation, pipe, valves, tank, etc	LS	1	\$750,000			\$150,000	\$180,000	\$930,000									
Groundwater Basin Management																		
a	Install Transducers	LS	1	\$15,000			\$3,000	\$3,600	\$18,600									
b	Install Monitoring Wells	LS	1	\$100,000			\$20,000	\$24,000	\$124,000									
c	Street Wellheads	LS	1	\$10,000			\$2,000	\$2,400	\$12,400									
d	Groundwater Basin Assessment - 10 years of data collection and reporting	LS	1	\$130,000			N/A	N/A	\$130,000									
Water Conservation and Demand Management																		
a	Customer Water Meter Installations by 2025 (approx. 3007 unmet/est at 2010)	EA	3007	\$350			\$1,062,450	\$275,480	\$1,337,930									
b	Water Conservation Program Feasibility Evaluation	LS	1	\$20,000			N/A	N/A	\$20,000									
Totals																		
									\$3,943,800	\$902,000	\$1,149,000	\$1,991,200	\$620,900	\$338,800	\$1,296,900	\$1,668,140	\$765,000	\$874,000

NOTES:

- 1 Contingency for unknown field conditions encountered at time of construction - Estimated construction costs plus 20%
- 2 Contingency for engineering, administration and construction inspection - Estimated construction costs plus 20%
- 3 All costs above are 2011 construction costs and NOT adjusted for inflation.

7. References

- Barton, J. Alan. 1991. *The Cenozoic Evolution of the San Joaquin Valley, California*. USGS Prof. Paper 1501.
- Berkstresser, C.F., Jr. 1973. *Base of Fresh Ground Water - Approximately 3,000 micromhos - in the Sacramento Valley and Sacramento - San Joaquin Delta, California*, USGS, WRI 73-40.
- Bertoldi, C.L., Johnston, R. H. and Evenson, K.D. 1991. *Ground Water in the Central Valley, California, a Summary Report*, USGS Prof. Paper 1401-A.
- Brabb, E.E., Sonneman, H.S. and Switzer, J.R., Jr. 1971. *Preliminary Geologic Map of the Mount Diablo - Byron Area, Contra Costa, Alameda, and San Joaquin Counties, California*. USGS open file report 71-53.
- California Department of Water Resources. 1967. *San Joaquin County Ground Water Investigation*. Bulletin No. 146. July.
- California Department of Water Resources. 2003. *California's Groundwater, Bulletin 118 Update 2003*.
- California Department of Water Resources. 2004. Individual Groundwater Basin Descriptions: http://www.groundwater.water.ca.gov/bulletin118/basin_desc/.
- California Department of Water Resources. 2005 through 2009. *Public Water System Statistics. Town of Discovery Bay Water System*.
- California Department of Water Resources. 2010. *20x2020 Water Conservation Plan*.
- California Division of Oil and Gas. 1982. *California Oil and Gas Fields Northern California Volume 3*, California Department of Conservation, Division of Oil and Gas, TR-10.
- California Legislature. 2006. *Assembly Bill No. 2572. Chapter 785. Approved and filed September 29, 2006*.
- California Legislature. 2009. *Senate Bill X 7-7, The Water Conservation Act of 2009. Approved and filed November 10, 2009*.
- California State Water Project Authority. 1956. *Investigation of the Sacramento-San Joaquin Delta, Ground Water Geology, Report No. 1*. May
- Davis, F.F., and Goldman, H.B. 1958. *Mines and Mineral Resources of Contra Costa County, California*. California Journal of Mines and Geology, V. 54, No. 4.

- Dibblee, T.W., Jr. 1980(a). *Preliminary Geologic Map of the Byron Hot Springs Quadrangle, Alameda and Contra Costa Counties, California*. USGS open file report 80-534.
- Dibblee, T.W., Jr. 1980(b). *Preliminary Geologic Map of Antioch South Quadrangle, Contra Costa County, California*. USGS open file report 80-536.
- Dibblee, T.W., Jr. 1980(c). *Preliminary Geologic Map of the Tassajara Quadrangle, Alameda and Contra Costa Counties, California*. USGS open file report 80-544.
- Fogelman, R.P. 1982. *Compilation of Selected Ground-Water Quality Data from the San Joaquin Valley, California*. USGS open file report 82-0335.
- Keeter, G.L. 1980. *Chemical Analyses for Selected Wells in San Joaquin County and Part of Contra Costa County, California*. USGS open file report 80-420.
- Luhdorff and Scalmanini, Consulting Engineers. 1999. *Investigation of Ground-Water Resources in the East Contra Costa Area*. Prepared for East County water entities.
- Luhdorff and Scalmanini, Consulting Engineers. 1999. *Water Master Plan, Discovery Bay*. Prepared for Discovery Bay Community Services District. April.
- Luhdorff and Scalmanini, Consulting Engineers. 1993. *Water Requirements and Supplies, Discovery Bay*. Prepared for the Hoffmann Company. January.
- Page, R.W. 1974. *Base and Thickness of the Post-Eocene Continental Deposits in the Sacramento Valley, California*. USGS WRI 73-45.
- Page, R.W. 1986. *Geology of the Fresh Ground-Water Basin of the Central Valley, California, with Texture Maps and Sections*. USGS Prof. Paper 1401-C.
- Sorenson, S.K. 1981. *Chemical Quality of Ground Water in San Joaquin and Part of Contra Costa Counties, California*. USGS WRI 81-26.
- Thesken, R.S. and Adams, R.L., 1995. *South Oakley and East Brentwood Gas Fields*. California Department of Conservation, Division of Oil, Gas and Geothermal Resources, Publication No. TR46.
- Wagner, D.L., Bertugno, E.J., and McJunkin, R.D., compilers. 1990. *Geologic Map of the San Francisco-San Jose Quadrangle*. California Division Mines and Geology, Regional Geologic Map Series, Map No. 5A; scale 1:250,000.

Appendix A

**Water Quality Table
(TDS and Specific Conductance)**

**Discovery Bay CSD
Summary of Total Dissolved Solids
and Specific Conductance in Wells**

	<u>Sp Conductance</u> uS/cm	<u>TDS</u> mg/L
MCL	2,200.00	1,500.00
Trigger	1,600.00	1,000.00
<u>Well 1B</u>		
5/9/1996	900	550
3/10/1997	920	670
5/10/1999	892	592
5/17/2000	864	598
7/10/2001	920	560
10/16/2002	900	530
12/29/2004	898	550
12/19/2005	906	540
3/10/2009	890	560
<u>Well 2</u>		
11/19/1986	600	532
9/12/1989	929	605
1/20/1993	1,000	560
3/10/1997	960	630
5/10/1999	921	588
5/17/2000	886	592
7/10/2001	940	560
12/11/2002	890	570
12/29/2004	942	570
12/19/2005	925	560
3/10/2009	950	590
<u>Well 4A</u>		
8/1/1996	1,000	550
3/10/1997	1,000	590
5/10/1999	905	600
5/17/2000	874	602
7/10/2001	910	600
10/16/2002	910	520
12/29/2004	924	590
12/19/2005	930	580
3/10/2009	920	580
<u>Well 5A</u>		
3/28/1990	985	753
1/20/1993	820	570
6/14/1996	1,000	590
3/10/1997	1,000	630
5/10/1999	1,010	667
5/17/2000	977	660
7/10/2001	1,100	640
10/16/2002	930	530
12/29/2004	1,190	750
12/19/2005	949	580
6/9/2009	970	560
6/16/2010	1,500	not analyzed
<u>Well 6</u>		
8/24/2009	930	550

PLATES

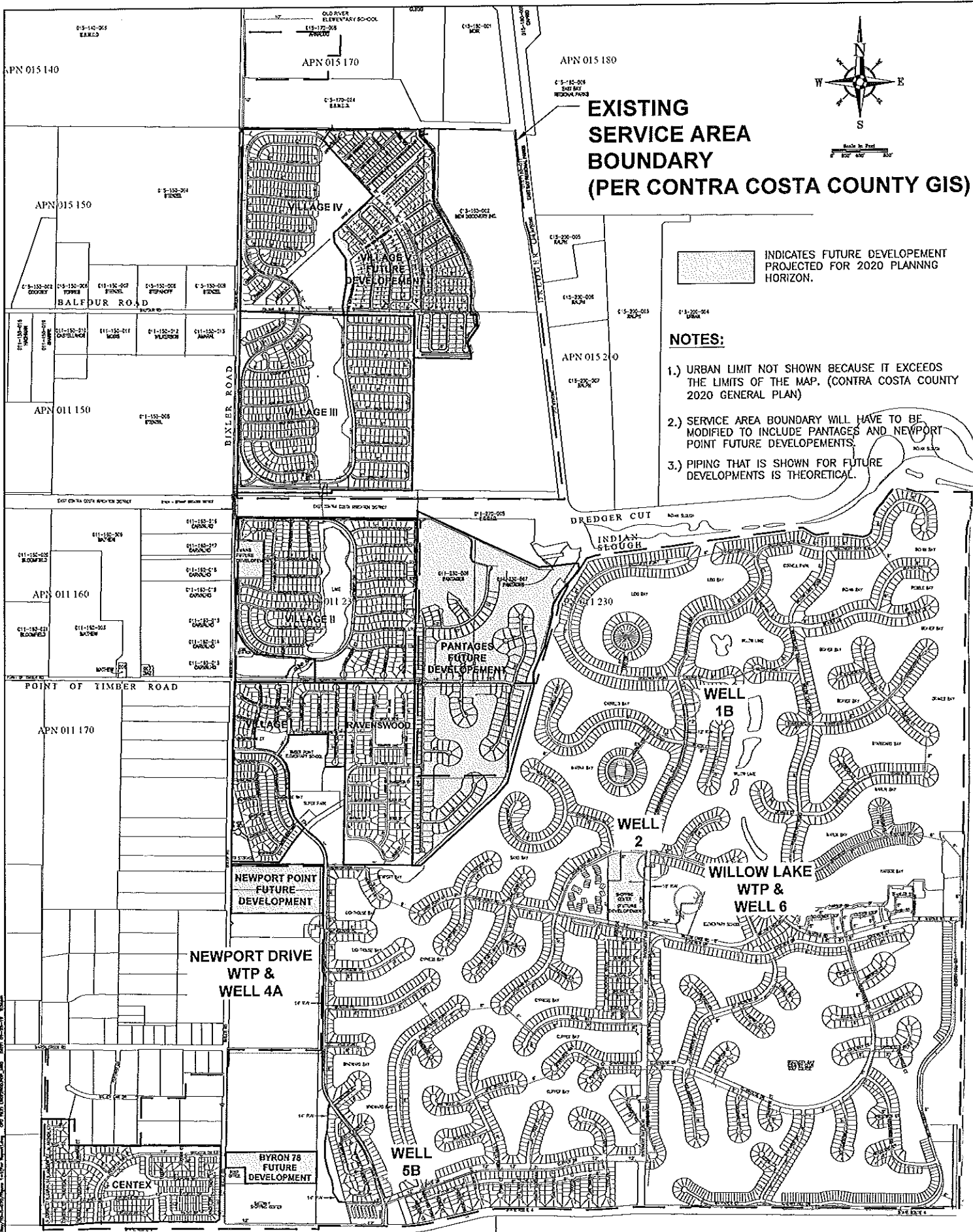

EXISTING SERVICE AREA BOUNDARY (PER CONTRA COSTA COUNTY GIS)

INDICATES FUTURE DEVELOPMENT PROJECTED FOR 2020 PLANNING HORIZON.

NOTES:

- 1.) URBAN LIMIT NOT SHOWN BECAUSE IT EXCEEDS THE LIMITS OF THE MAP. (CONTRA COSTA COUNTY 2020 GENERAL PLAN)
- 2.) SERVICE AREA BOUNDARY WILL HAVE TO BE MODIFIED TO INCLUDE PANTAGES AND NEWPORT POINT FUTURE DEVELOPMENTS.
- 3.) PIPING THAT IS SHOWN FOR FUTURE DEVELOPMENTS IS THEORETICAL.

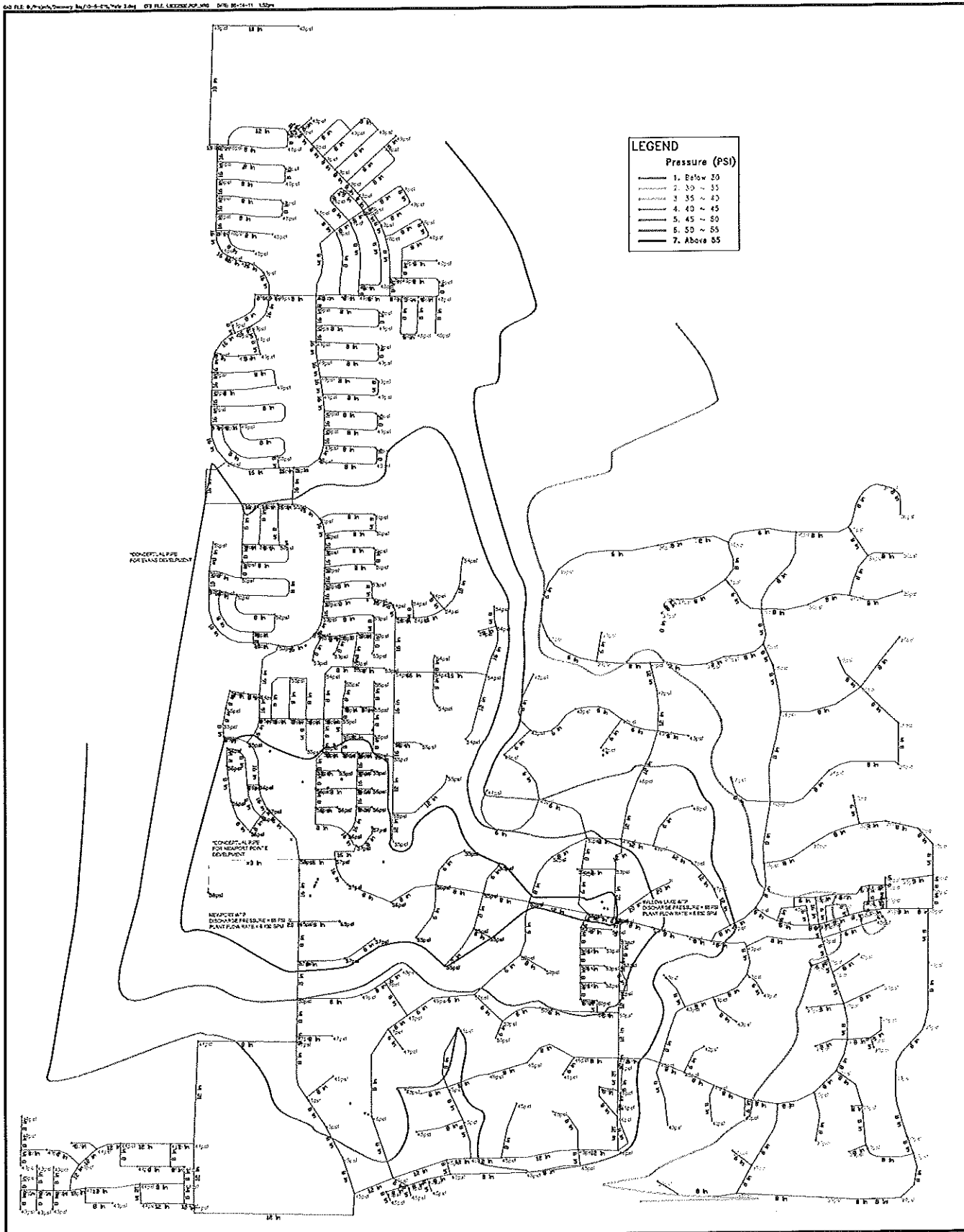

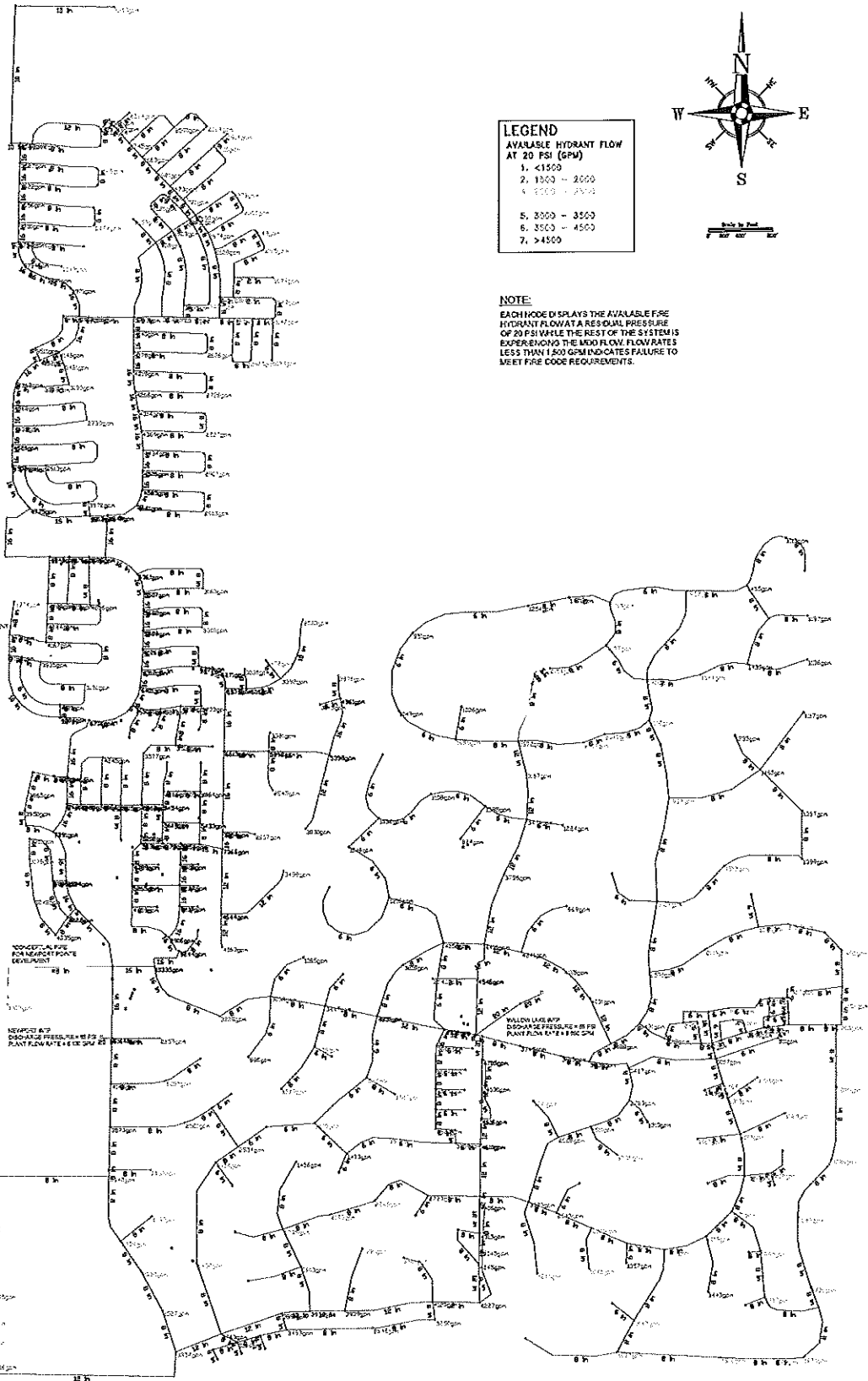

LEGEND
AVAILABLE HYDRANT FLOW AT 20 PSI (GPM)

1.	<1500
2.	1500 - 2000
3.	2000 - 2500
4.	2500 - 3000
5.	3000 - 3500
6.	3500 - 4000
7.	>4000

NOTE:
EACH NODE DISPLAYS THE AVAILABLE FIRE HYDRANT FLOW AT A RESIDUAL PRESSURE OF 20 PSI WHILE THE REST OF THE SYSTEM IS EXPERIENCING THE MOD FLOW. FLOW RATES LESS THAN 1500 GPM INDICATES FAILURE TO MEET FIRE CODE REQUIREMENTS.

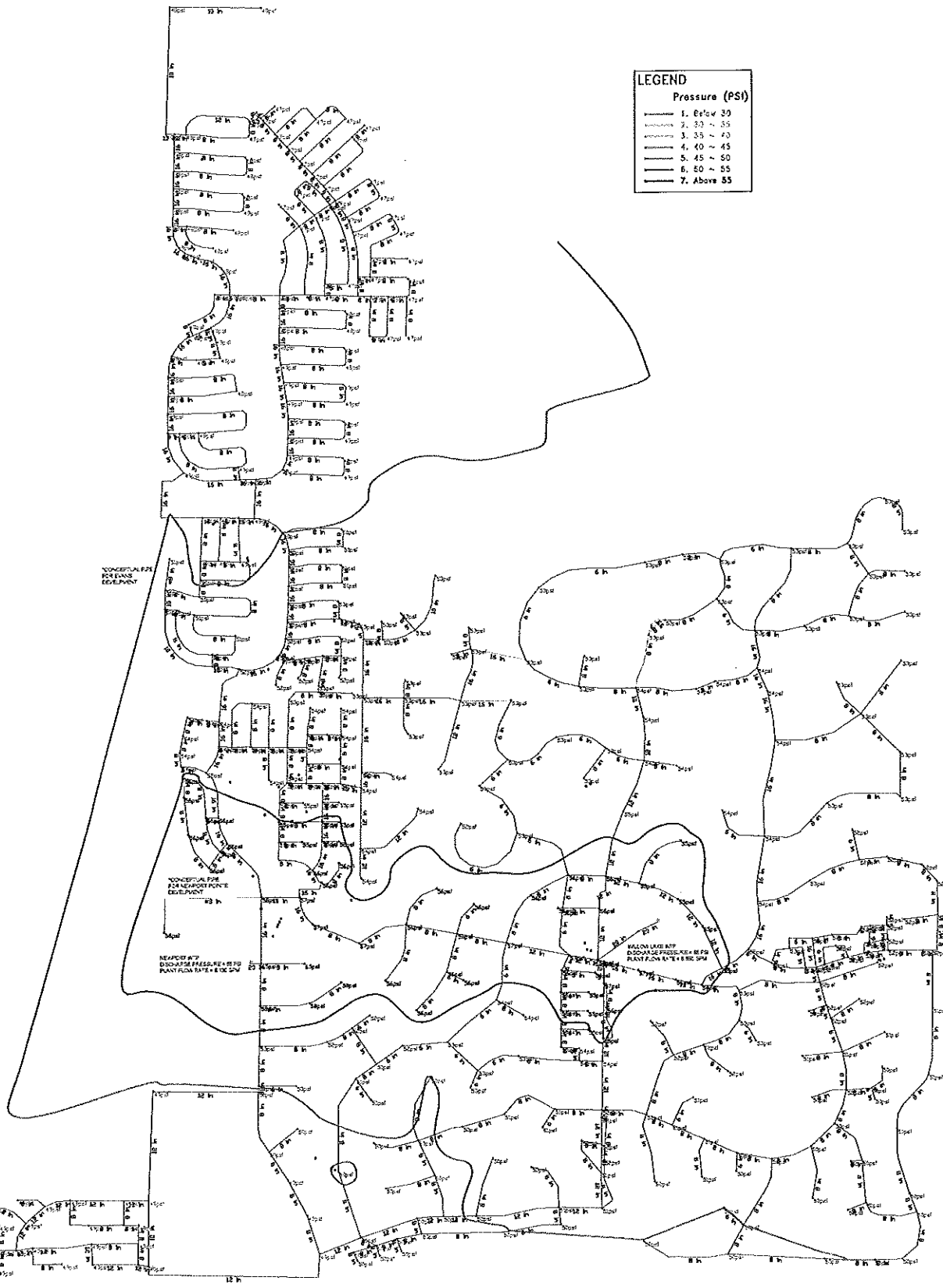

LEGEND	
Pressure (PSI)	
———	1. 65' or 20
———	2. 53 ~ 55
———	3. 35 ~ 43
———	4. 40 ~ 45
———	5. 45 ~ 50
———	6. 50 ~ 55
———	7. Above 55

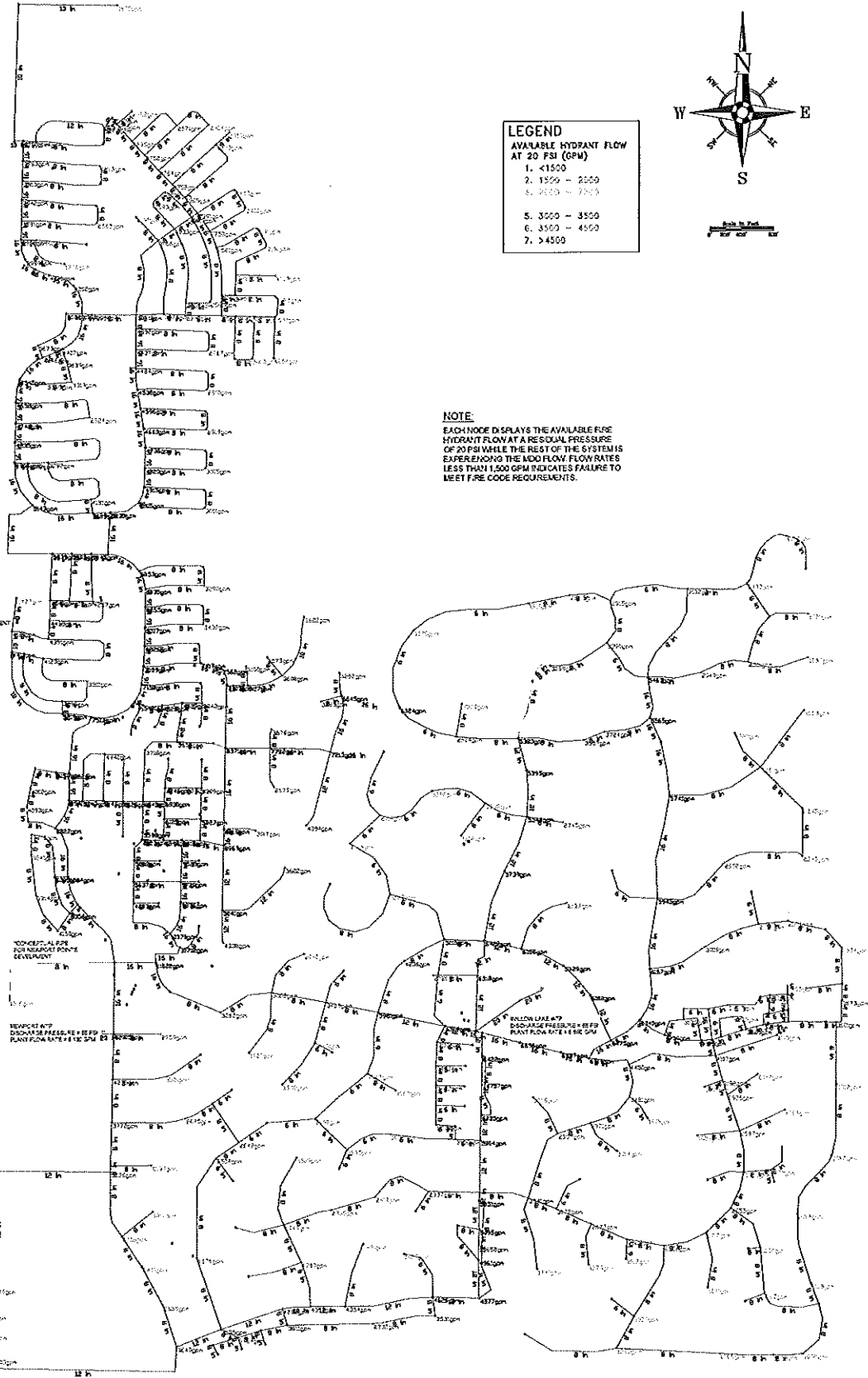

LEGEND
AVAILABLE HYDRANT FLOW AT 20 PSI (GPM)

1. <1500
2. 1500 - 2000
3. 2000 - 2500
4. 2500 - 3000
5. 3000 - 3500
6. 3500 - 4000
7. >4500

NOTE:
 EACH NODE DISPLAYS THE AVAILABLE FIRE HYDRANT FLOW AT A RESIDUAL PRESSURE OF 20 PSI WHILE THE REST OF THE SYSTEMS EXPERIENCE THE MAXIMUM FLOW RATES. LESS THAN 1,500 GPM INDICATES FAILURE TO MEET FIRE CODE REQUIREMENTS.

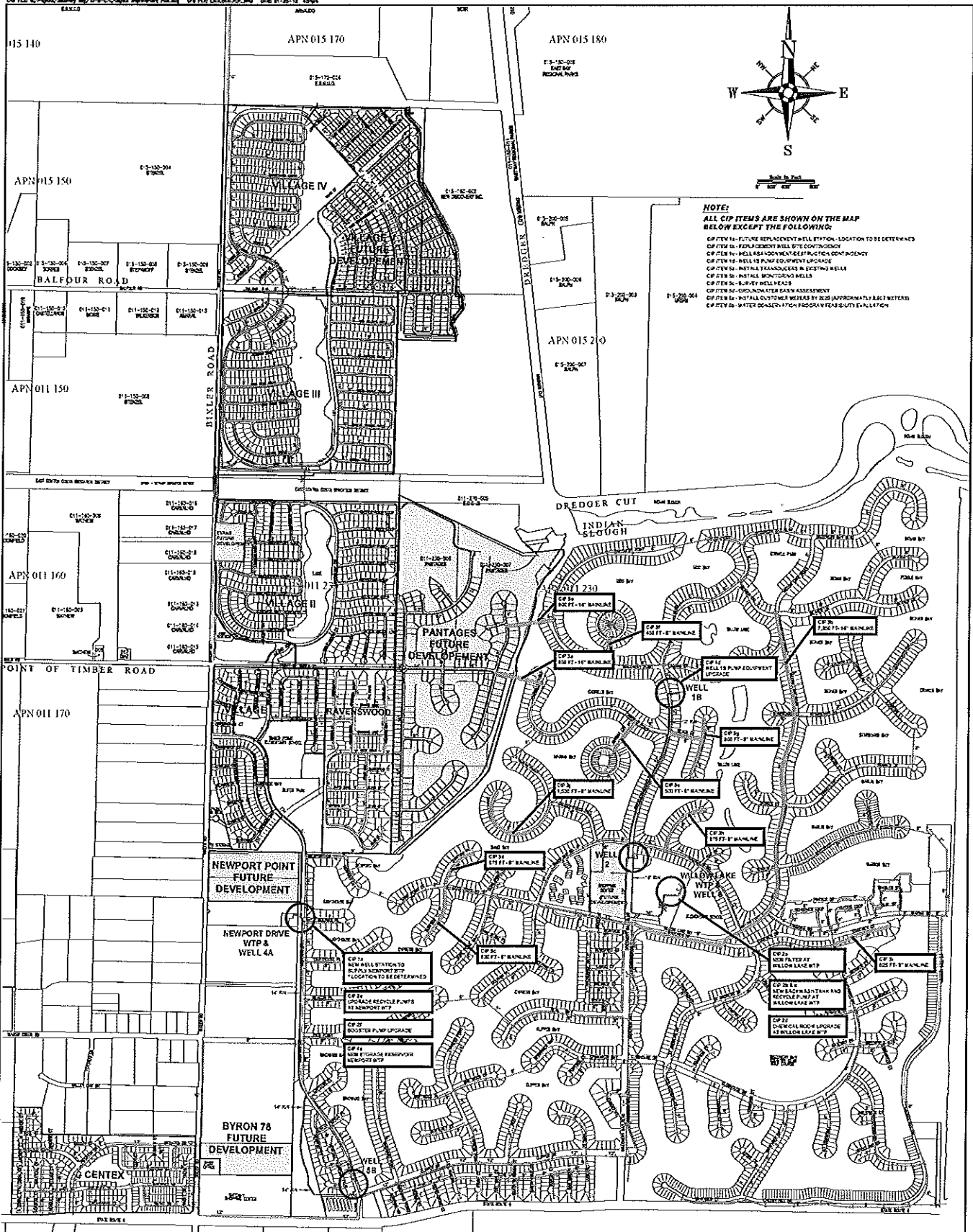

NOTES:
ALL CIP ITEMS ARE SHOWN ON THE MAP BELOW EXCEPT THE FOLLOWING:
 CIP ITEM 14 - FUTURE REPLACEMENT WELL STATION - LOCATION TO BE DETERMINED
 CIP ITEM 16 - REPLACEMENT WELL BY THE CONTRACTOR
 CIP ITEM 17 - WELL REPAIR/MAINTENANCE/RESTRUCTION CONTRACTOR
 CIP ITEM 18 - WELLS TO PUMP EQUIPMENT UPGRADE
 CIP ITEM 19 - INSTALL TRANSDUCERS IN EXISTING WELLS
 CIP ITEM 20 - INSTALL MONITORING WELLS
 CIP ITEM 21 - SURVEY WELL HEADS
 CIP ITEM 22 - CONDUCT WATER BIAS ASSESSMENT
 CIP ITEM 23 - INSTALL OUTSIDE WELLS BY 2008 (APPROXIMATELY 3.62 METERS)
 CIP ITEM 24 - WATER QUALITY MONITORING PROGRAM EVALUATION