



**TOWN OF DISCOVERY BAY**  
*A COMMUNITY SERVICES DISTRICT*



President – Robert Leete • Vice-President – Kevin Graves • Director – Bill Mayer • Director – Bill Pease • Director – Chris Steele

---

**TOWN OF DISCOVERY BAY**  
**COMMUNITY SERVICES DISTRICT**  
**AGENDA PACKET**

**Regular Board Meeting**  
**Wednesday, December 6, 2017**

**7:00 P.M. Regular Board Meeting**

**Community Center**  
**1601 Discovery Bay Boulevard**



# TOWN OF DISCOVERY BAY

A COMMUNITY SERVICES DISTRICT



President – Robert Leete • Vice-President – Kevin Graves • Director – Bill Mayer • Director – Bill Pease • Director – Chris Steele

**NOTICE OF THE REGULAR MEETING  
OF THE BOARD OF DIRECTORS  
OF THE TOWN OF DISCOVERY BAY**

**Wednesday December 6, 2017**

**REGULAR MEETING 7:00 P.M.**

**Community Center**

**1601 Discovery Bay Boulevard, Discovery Bay, California**

**Website address: [www.todb.ca.gov](http://www.todb.ca.gov)**

**REGULAR MEETING 7:00 P.M.**

**A. ROLL CALL AND PLEDGE OF ALLEGIANCE**

1. Call business meeting to order 7:00 p.m.
2. Pledge of Allegiance
3. Roll Call

**B. PUBLIC COMMENTS (Individual Public Comments will be limited to a 3-minute time limit)**

During Public Comments, the public may address the Board on any issue within the District's jurisdiction which is not on the Agenda. The public may comment on any item on the Agenda at the time the item is before the Board for consideration. Any person wishing to speak must come up and speak from the podium and will have 3 minutes to make their comment. There will be no dialog between the Board and the commenter. Any clarifying questions from the Board must go through the President.

**C. CONSENT CALENDAR**

All matters listed under the CONSENT CALENDAR are considered by the District to be routine and will be enacted by one motion.

1. Approve DRAFT minutes of regular meeting for November 15, 2017.
2. Approve Register of District Invoices.
3. Approve Board and Management Attendance at the 2018 Annual State of the Town Event.
4. Approve Board Officers for 2018 Calendar Year.

**D. AREA AGENCIES REPORTS / PRESENTATION**

1. Supervisor Diane Burgis, District III Report
2. Sheriff's Office Report
3. CHP Report

**E. LIAISON REPORTS**

**F. PRESENTATIONS**

1. District Water Engineer Shobe – Water Meter Project Report.

**G. BUSINESS AND ACTION ITEMS**

1. Discussion and possible action regarding the cancellation of the Regular Board Meeting.
2. Discussion and possible action regarding the Electronic Check Signature Process.
3. Discussion and possible action regarding the Annual Board Workshop for 2018.
4. Discussion and possible action regarding the Agency Comment Request – Land Use Permit and Development Plan Application LP17-2027 – Upgrades to the Existing McDonald's.
5. Discussion and possible action regarding the approval of Notice of Completion for Plant No. 2 - Effluent Filtration Project (Master Plan Projects No. 5, 7, 10, 12).

**H. MANAGER'S REPORT**

**I. INFORMATIONAL ITEMS ONLY**

**J. DIRECTORS' REPORTS**

1. Standing Committee Reports
2. Other Reportable Items

**K. GENERAL MANAGER'S REPORT**

**L. CORRESPONDENCE RECEIVED**

1. Received – East Contra Costa Fire Protection District meeting minutes for November 6, 2017.

**M. FUTURE AGENDA ITEMS**

**N. ADJOURNMENT**

1. Adjourn to the next regular meeting of December 20, 2017 beginning at 7:00 p.m. at the Community Center located at 1601 Discovery Bay Boulevard.

"This agenda shall be made available upon request in alternative formats to persons with a disability, as required by the American with Disabilities Act of 1990 (42 U.S.C. § 12132) and the Ralph M. Brown Act (California Government Code § 54954.2). Persons requesting a disability related modification or accommodation in order to participate in the meeting should contact the Town of Discovery Bay, at (925) 634-1131, during regular business hours, at least forty-eight hours prior to the time of the meeting."

"Materials related to an item on the Agenda submitted to the Town of Discovery Bay after distribution of the agenda packet are available for public inspection in the District Office located at 1800 Willow Lake Road during normal business hours."



# TOWN OF DISCOVERY BAY

A COMMUNITY SERVICES DISTRICT



President – Robert Leete • Vice-President – Kevin Graves • Director – Bill Mayer • Director – Bill Pease • Director – Chris Steele

## MINUTES OF THE REGULAR MEETING OF THE BOARD OF DIRECTORS OF THE TOWN OF DISCOVERY BAY

Wednesday November 15, 2017  
REGULAR MEETING 7:00 P.M.

Community Center

1601 Discovery Bay Boulevard, Discovery Bay, California

Website address: [www.todb.ca.gov](http://www.todb.ca.gov)

### REGULAR MEETING 7:00 P.M.

#### A. ROLL CALL AND PLEDGE OF ALLEGIANCE

1. Call business meeting to order 7:00 p.m. – By President Leete
2. Pledge of Allegiance – Led by Director Pease
3. Roll Call – All present with the exception of Director Steele
4. Director Steele arrived at 7:57 p.m.

#### B. PUBLIC COMMENTS (Individual Public Comments will be limited to a 3-minute time limit)

None

#### C. CONSENT CALENDAR

All matters listed under the CONSENT CALENDAR are considered by the District to be routine and will be enacted by one motion.

1. Approve DRAFT minutes of regular meeting for November 1, 2017.
2. Approve Register of District Invoices.

Motion by: Director Pease to approve the Consent Calendar.

Second by: Vice-President Graves

Vote: Motion Carried – AYES: 4 – President Leete, Vice-President Graves, Director Mayer, Director Pease  
NOES: 0, ABSENT: 1 – Director Steele.

#### D. PRESENTATIONS

1. Donation of the Byron Delta Lions Bench.

Parks and Landscaping Manager Miller – Provided the details regarding the donation of the Byron Delta Lions Bench celebrating the 100<sup>th</sup> Birthday of being one of the largest service clubs in the world this year. Byron Delta Lions Linda Barbara – Provided additional details regarding the Bench related to the type of material the bench is made of, requesting the bench to be permanently affixed, along with an engraving observing the 100<sup>th</sup> Birthday of the Lions Club. There was discussion regarding the location.

2. CSDA Field Coordinator, Colleen Haley - Presenting the Special District Recognition.

CSDA Field Coordinator, Colleen Haley – Provided the details of the Special District Recognition regarding three (3) certificates being presented along with the criteria. Certificates of recognition of Special District Governance and the Gold Status were presented to General Manager Davies and Director Bill Mayer along with the full Board. General Manager Davies also presented a Gold Status Recognition from Senator Glazer. The General Manager and the Board thanked Executive Assistant Heini for her excellent effort for the Gold Status. President Leete also stated that there are only seven (7) Districts in the State of California that have this Certification.

**E. AREA AGENCIES REPORTS / PRESENTATION**

**1. East Contra Costa Fire Protection District Report**

Battalion Chief Ross Macumber – Provided the details regarding the East Contra Costa Fire Protection District Report, PG&E Outage Caused by a Tractor Trailer, tree removal, the ECCFPD website, also social media, Open House in March (10<sup>th</sup> or 24<sup>th</sup>). There was discussion regarding the ECCFPD Outreach meetings and the Finance meetings (open to the public), Pulse Point - send out notices to those that are trained in CPR and ADD.

**F. MONTHLY WATER AND WASTEWATER REPORT – VEOLIA**

**1. Veolia Report – Month of October 2017**

Project Manager Berney Sadler – Provided the details of the October 2017 Monthly Operations Report. There was discussion regarding the total number of manholes in Discovery Bay (close to 1000).

**G. BUSINESS AND ACTION ITEMS**

**1. Discussion and possible action on converting the remaining Cornell Park Tennis Court to Pickleball.**

General Manager Davies – Provided an overview of the Cornell Park and Tennis Court conversion - Parks and Recreation Committee heard from the Pickleball community regarding the conversion of the Cornell Park Tennis Court to Pickleball Courts. The Pickleball community will find outside funding to make the conversion. The Parks and Recreation Committee recommend that the Board approve the conversion contingent on the funding plan (for cost of conversion, maintenance, periodic restoration).

Recreation Programs Supervisor Kaiser – Provided additional details regarding Pickleball as a rapidly growing sport and the need for additional facilities and a background of the conversion.

Public Comment Regarding:

- In need of additional Pickleball Courts, converting the courts is the best solution for Discovery Bay.

There was discussion regarding Pickleball and the request for the conversion; The Pickleball Club will fund the conversion of the courts. The discussion continued regarding the conversion related to notifying the Tennis group along with the hours and lighting for the Tennis Courts at Cornell Park and the Discovery Bay Community Center.

Motion by: Director Pease to recommend the conversion of the remaining Cornell Park Tennis Court to four (4) Pickleball courts and to authorize staff to pursue with the Discovery Bay Pickleball Club funding alternatives, including initiating grant application(s), and return to the Board with a Discovery Bay Pickleball Club Funding Plan.

Second by: Vice-President Graves

Vote: Motion Carried – AYES: 4 – President Leete, Vice-President Graves, Director Mayer, Director Pease  
NOES: 0, ABSENT: 1 – Director Steele.

**2. Discussion and possible action regarding stationary electronic signboard (s).**

General Manager Davies – Provided the details regarding the stationary electronic signboard; the Communications Committee is recommending that the Board approve the electronic signboard be installed at the Well No.4 site located at the East edge of Discovery Bay Boulevard just North of Clipper Drive.

Office Assistant Rajala – Provided the details of the presentation regarding the stationary electronic signboard(s) related to the locations and cost breakdown.

General Manager Davies – Provided additional details regarding the site location of Well No. 4 (ease of cost and installation) along with the timeframe of installation (6 weeks). There was discussion regarding the need for a permanent sign, items to be placed on the sign; pertinent items, or Town of Discovery Bay Logo and Welcome to Discovery Bay. The discussion continued regarding the current signboard related to improving communicating to the residents, previous Board discussion regarding a signboard, and enhancing the Town of Discovery Bay with an attractive signboard.

Motion by: Vice-President Graves to approve the recommendation of the Communications Committee to purchase and install an electronic signboard at the Well #4 site location and authorize the General Manager to execute all contracts and documents related to the purchase and installation thereof, in an amount not to exceed the estimated total cost of purchase and installation, plus an 8.25% contingency.

Second by: Director Mayer

Vote: Motion Carried – AYES: 3 – President Leete, Vice-President Graves, Director Mayer, NOES: 1 – Director Pease, ABSENT: 1 – Director Steele.

**3. Discussion and possible action regarding First Amendment to the MOU for the Development of a Groundwater Sustainability Plan.**

General Manager Davies – Provided a background and details of the formation of Discovery Bay as a Groundwater Sustainable Agency and entering into a Memorandum of Understanding (MOU) for the GSA.

There was discussion regarding the financing for the Groundwater Sustainable Plan

Motion by: Vice-President Graves to authorize the General Manager to execute and carryout the terms of a

First Amendment to the Memorandum of Understanding for the Development of a Groundwater Sustainability Plan for the East Contra Costa County Portion of the Tracy Subbasin with the City of Antioch, Byron-Bethany Irrigation District, Contra Costa Water District, Contra Costa County, Diablo Water District, East Contra Costa Irrigation District, and City of Brentwood that provides for consultant contracting and cost sharing among the Agencies in the preparation of a Groundwater Sustainability Plan ("GSP").

In addition, authorize the General Manager to agree to waive the County's December 1, 2017 deadline for providing written notice as to whether or not to provide in-kind services in lieu of paying its share of GSP costs during FY2017/18, providing that that the County gives its notice on or before December 15, 2017.

Second by: Director Pease

Vote: Motion Carried – AYES: 4 – President Leete, Vice-President Graves, Director Mayer, Director Pease  
NOES: 0, ABSENT: 1 – Director Steele.

## **H. INFORMATIONAL ITEMS ONLY**

### **I. DIRECTORS' REPORTS**

#### **1. Standing Committee Reports**

Vice-President Graves – Provided the details of the Internal Operations meeting held on November 15, 2017 related to the calendars, Public Records Act, policies and procedures.

Director Mayer – Provided the details of the Finance Committee meeting held on November 13, 2017 related to street lights (692) and fire hydrants (543), insurance policies, electronic check signature process and financial dashboards.

Director Mayer – Provided the details of the East Contra Costa Fire Protection District meeting regarding the election ballot.

Director Mayer – Provided the details of A Neighborhood Watch meeting (good turnout).

#### **2. Other Reportable Items - None**

### **J. MANAGER'S REPORT**

None

### **K. GENERAL MANAGER'S REPORT**

General Manager Davies – Provided the details of the Parade of Lights which will be held on December 2, 2017 at 6:00 p.m., also provided details regarding correspondence item L-2.

### **L. CORRESPONDENCE RECEIVED**

1. Received - East Contra Costa Fire Protection District meeting minutes for October 2, 2017.

2. Received – Letter from PG&E regarding the accident related to the interruption of power on October 26, 2017 and where to file damage claims.

### **M. FUTURE AGENDA ITEMS**

None

The regular meeting adjourned at 7:59 p.m. to the Closed Session.

### **N. OPEN SESSION DISCLOSURE OF CLOSED SESSION AGENDA**

(Government Code Section 54957.7)

Legal Counsel Attebery – The Board is now adjourning into closed session regarding item O-1.

### **O. CLOSED SESSION**

1. Conference with Legal Counsel—Anticipated Litigation Pursuant to Government Code Section 54956.9(b)  
One potential Case

### **P. RETURN TO OPEN SESSION; REPORT ON CLOSED SESSION**

(Government Code Section 54957.1)

Legal Counsel Attebery – Reporting from Closed Session on item O-1, there is no reportable action.

### **Q. ADJOURNMENT**

1. The meeting adjourned at 8:20 p.m. to the regular meeting on December 6, 2017 beginning at 7:00 a.m. at the Community Center located at 1601 Discovery Bay Boulevard.

//cmc – 11-17-17

<http://www.todb.ca.gov/agendas-minutes>



# Town of Discovery Bay

*"A Community Services District"*

## STAFF REPORT

Meeting Date

December 06, 2017

**Prepared By:** Dina Breitstein, Finance Manager & Lesley Marable, Accountant  
**Submitted By:** Michael R. Davies, General Manager

MRD

### Agenda Title

Approve Register of District Invoices.

### Recommended Action

Staff recommends that the Board approve the listed invoices for payment

### Executive Summary

District invoices are paid on a regular basis, and must obtain Board authorization prior to payment. Staff recommends Board authorization in order that the District can continue to pay warrants in a timely manner.

### Fiscal Impact:

**Amount Requested** \$ 286,233.15

**Sufficient Budgeted Funds Available?:** Yes (If no, see attached fiscal analysis)

**Prog/Fund #** See listing of invoices. **Category:** Operating Expenses and Capital Improvements

### Previous Relevant Board Actions for This Item

### Attachments

Request For Authorization to Pay Invoices for the Town of Discovery Bay CSD 2017/2018  
Request For Authorization to Pay Invoices for the Discovery Bay Lighting & Landscape District # 8 2017/2018  
Request For Authorization to Pay Invoices for the Discovery Bay Lighting & Landscape District # 9 2017/2018

AGENDA ITEM: C-2

**Request For Authorization To Pay Invoices (RFA)  
For The Meeting On December 06, 2017  
Town of Discovery Bay CSD  
For Fiscal Year's 7/17 - 6/18**

<u>Vendor Name</u>	<u>Invoice Number</u>	<u>Description</u>	<u>Invoice Date</u>	<u>Amount</u>
<b>Contra Costa County Reimbursement</b>				
Tee Janitorial & Maintenance	9052	Janitorial Service Nov 2017 (Z57,Z61)	11/20/17	\$80.00
U.S. Bank Corporate Payment System	4246044555703473/017	Landscape Reimb (Z35,Z57,Z61)	10/25/17	\$425.66
			<b>Contra Costa County</b>	
			<b>Sub-Total</b>	<b>\$505.66</b>
<b>Water</b>				
Aflac	203953	Supplemental Insurance Nov 2017	11/27/17	\$331.30
ASPIRE	13145 113017	457(b) 11/16/17-11/30/17	11/30/17	\$287.02
Big Dog Computer	BDC33345	IT Support, New System Set-up	11/17/17	\$256.90
Bill Pease	NOV 2017	Expense Report Nov 2017	11/20/17	\$92.00
CaliforniaChoice Benefit Admin	2812629/53040	Health Insurance Jan 2018	11/28/17	\$5,366.94
Chris Steele	NOV 2017	Expense Report Nov 2017	11/20/17	\$138.00
Cintas	185631186	Mats, Etc.	11/08/17	\$13.59
Cintas	185632178	Mats, Etc.	11/15/17	\$12.30
Cintas	185633239	Mats, Etc.	11/22/17	\$12.30
Digital Deployment, Inc.	95189	Town Of Discovery Bay Website Changes	05/19/17	\$540.00
Digital Deployment, Inc.	95390	Town Of Discovery Bay Website Changes	06/30/17	\$300.00
Discovery Pest Control	226271	Pest Control	11/15/17	\$27.20
Du-All Safety	19295	Safety Training And Support	10/31/17	\$204.00
Freedom Mailing Service, Inc	32458	Water Bill Processing Oct 2017	11/14/17	\$2,125.64
Hanford ARC	1	Hydrant Meter Deposit Refund	11/21/17	\$915.00
Helen Ward	LAGUNA COURT	Property Tax Adjustment FY16/17, FY 17/18	12/06/17	\$564.54
J.W. Backhoe & Construction, Inc.	2880	Install Service Discovery Bay Blvd	11/06/17	\$9,456.95
J.W. Backhoe & Construction, Inc.	2882	Replace AMS Cherry Hills	11/07/17	\$4,221.57
J.W. Backhoe & Construction, Inc.	2889	Water Leak Beaver Lane	11/09/17	\$2,383.46
J.W. Backhoe & Construction, Inc.	2890	Hauled Cutback to WWTP#1	11/09/17	\$807.80
J.W. Backhoe & Construction, Inc.	2894	Replace Meter Setters And Pour Concrete Double Pt & South Pt	11/14/17	\$5,570.15
J.W. Backhoe & Construction, Inc.	2895	Locate AMS Sand Point Road	11/14/17	\$2,404.24
J.W. Backhoe & Construction, Inc.	2896	Water Leak Discovery Point	11/14/17	\$3,991.81
J.W. Backhoe & Construction, Inc.	2897	Replace Manifold Willow Lake Road	11/14/17	\$3,896.60
J.W. Backhoe & Construction, Inc.	2898	Water Leak Cabrillo Point	11/14/17	\$3,842.12
J.W. Backhoe & Construction, Inc.	2899	Water Leak Drake Drive	11/14/17	\$1,916.10
Kevin Graves	NOV 2017	Expense Report Nov 2017	11/20/17	\$138.00
Lesley Marable	NOV 2017	Expense Report Nov 2017	11/22/17	\$37.36
Luhdorff & Scalmanini	33323	Water Meter Installation Project	10/29/17	\$30,386.11
Luhdorff & Scalmanini	33323	General Services	10/29/17	\$5,085.15
Luhdorff & Scalmanini	33335	Bi-Annual Well Testing	10/29/17	\$8,831.50
Luhdorff & Scalmanini	33336	SCADA Upgrades Newport	10/29/17	\$9,688.10
Luhdorff & Scalmanini	33382	Groundwater Sustainability Plan	10/29/17	\$747.00
National Meter & Automation, Inc.	S1090287.001	Water Meter Project, Meters	10/31/17	\$5,539.42
National Meter & Automation, Inc.	S1090287.002	Water Meter Project, Meters	10/31/17	\$924.90
Neopost	7900044908384658/711	Postage	11/14/17	\$15.60
Office Depot	977848414001	Office Supplies	11/07/17	\$7.26
Office Depot	977848670001	Office Supplies	11/07/17	\$29.83
Office Depot	977848671001	Office Supplies	11/07/17	\$7.79
Pacific Gas & Electric	1521433231-2/110917	Electric & Gas Bill	11/09/17	\$7,671.18
Pacific Gas & Electric	2943721807-5/110817	Electric & Gas Bill	11/08/17	\$32,985.36
Pacific Surfacing, Inc.	1	Hydrant Meter Deposit Refund	11/09/17	\$915.00
Physio-Control, Inc.	417167050	AED Annual Maintenance	11/04/17	\$102.57
R & B Company	S1699793.001	Meter Gaskets	11/15/17	\$54.13
ReliaStar Life Insurance Company	#JRS2 457(B) 113017	457(b) 11/16/17-11/30/17	11/30/17	\$172.00
Robert Leete	NOV 2017	Expense Report Nov 2017	11/20/17	\$184.00
SDRMA	25048	Ancillary Benefits Dec 2017	11/22/17	\$571.75
Shred-It USA-Concord	8123505259	Shredding Service	11/07/17	\$23.54
TASC	450775312003/121517	IRS Section 125 Health Spending Plan Dec 2017	12/01/17	\$290.13
TASC	IN1160125	Annual Administration Fees 2018	11/18/17	\$395.76
Tee Janitorial & Maintenance	9052	Janitorial Service Nov 2017	11/20/17	\$285.60
U.S. Bank Corporate Payment System	4246044555703473/017	Travel & Meetings	10/25/17	\$284.38
U.S. Bank Corporate Payment System	4246044555703473/017	Telephone General	10/25/17	\$355.82
U.S. Bank Corporate Payment System	4246044555703473/017	Telecom Networking	10/25/17	\$401.78
U.S. Bank Corporate Payment System	4246044555703473/017	Vehicle & Equipment Fuel	10/25/17	\$521.44
U.S. Bank Corporate Payment System	4246044555703473/017	Info System	10/25/17	\$339.20
U.S. Bank Corporate Payment System	4246044555703473/017	Postage	10/25/17	\$6.65
U.S. Bank Corporate Payment System	4246044555703473/017	Office Supplies	10/25/17	\$77.32



U.S. Bank Corporate Payment System	4246044555703473/017	Special Expense	10/25/17	\$31.98
Univar	SJ849318	Chemicals Delivered 11/06/17	11/10/17	\$269.70
Univar	SJ849319	Chemicals Delivered 11/06/17	11/06/17	\$316.20
Univar	SJ851066	Chemicals Delivered 11/20/17	11/21/17	\$188.33
Univar	SJ851067	Chemicals Delivered 11/20/17	11/21/17	\$267.38
Water Utility Customer	Pardee Court	Refund Overpayment	11/09/17	\$150.99
William Mayer	NOV 2017	Expense Report Nov 2017	11/20/17	\$184.00

**Water Sub-Total \$158,161.74**

**Wastewater**

Aflac	203953	Supplemental Insurance Nov 2017	11/27/17	\$496.96
ASPIRE	13145 113017	457(b) 11/16/17-11/30/17	11/30/17	\$430.54
Big Dog Computer	BDC33345	IT Support, New System Set-up	11/17/17	\$385.36
Bill Pease	NOV 2017	Expense Report Nov 2017	11/20/17	\$138.00
CaliforniaChoice Benefit Admin	2812629/53040	Health Insurance Jan 2018	11/28/17	\$8,050.41
Chris Steele	NOV 2017	Expense Report Nov 2017	11/20/17	\$207.00
Cintas	185631186	Mats, Etc.	11/08/17	\$20.35
Cintas	185631186	Uniforms	11/08/17	\$10.31
Cintas	185632178	Mats, Etc.	11/15/17	\$18.45
Cintas	185632178	Uniforms	11/15/17	\$5.56
Cintas	185633239	Mats, Etc.	11/22/17	\$18.45
Cintas	185633239	Uniforms	11/22/17	\$5.56
Comcast	8155400350232938/711	WWTP#2 Internet Service	11/03/17	\$109.95
Comcast	8155400350232946/711	WWTP#1 Internet Service	11/03/17	\$101.08
Digital Deployment, Inc.	95189	Town Of Discovery Bay Website Changes	05/19/17	\$810.00
Digital Deployment, Inc.	95390	Town Of Discovery Bay Website Changes	06/30/17	\$450.00
Discovery Pest Control	226136	Pest Control WWTP#1	11/03/17	\$70.00
Discovery Pest Control	226271	Pest Control	11/15/17	\$40.80
Du-All Safety	19295	Safety Training And Support	10/31/17	\$306.00
Helen Ward	LAGUNA COURT	Property Tax Adjustment FY16/17, FY 17/18	12/06/17	\$1,293.02
Kevin Graves	NOV 2017	Expense Report Nov 2017	11/20/17	\$207.00
Lesley Marable	NOV 2017	Expense Report Nov 2017	11/22/17	\$56.05
Neopost	7900044908384658/711	Postage	11/14/17	\$23.40
Office Depot	977848414001	Office Supplies	11/07/17	\$10.88
Office Depot	977848670001	Office Supplies	11/07/17	\$44.74
Office Depot	977848671001	Office Supplies	11/07/17	\$11.68
Pacific Gas & Electric	1181942262-4/110717	Electric & Gas Bill	11/07/17	\$3,890.77
Pacific Gas & Electric	7312115758-7/111317	Electric & Gas Bill	11/13/17	\$34,552.84
Physio-Control, Inc.	417167050	AED Annual Maintenance	11/04/17	\$153.87
ReliaStar Life Insurance Company	#JRS2 457(B) 113017	457(b) 11/16/17-11/30/17	11/30/17	\$258.00
Robert Leete	NOV 2017	Expense Report Nov 2017	11/20/17	\$276.00
SDRMA	25048	Ancillary Benefits Dec 2017	11/22/17	\$857.63
Shred-It USA-Concord	8123505259	Shredding Service	11/07/17	\$35.31
TASC	450775312003/121517	IRS Section 125 Health Spending Plan Dec 2017	12/01/17	\$435.20
TASC	IN1160125	Annual Administration Fees 2018	11/18/17	\$593.64
Tee Janitorial & Maintenance	9052	Janitorial Service Nov 2017	11/20/17	\$428.40
U.S. Bank Corporate Payment System	4246044555703473/017	Travel & Meeting	10/25/17	\$324.01
U.S. Bank Corporate Payment System	4246044555703473/017	Telephone General	10/25/17	\$1,098.56
U.S. Bank Corporate Payment System	4246044555703473/017	Telecom Networking	10/25/17	\$602.66
U.S. Bank Corporate Payment System	4246044555703473/017	Vehicle & Equipment Fuel	10/25/17	\$234.63
U.S. Bank Corporate Payment System	4246044555703473/017	General Repairs	10/25/17	\$6.49
U.S. Bank Corporate Payment System	4246044555703473/017	Info System	10/25/17	\$508.79
U.S. Bank Corporate Payment System	4246044555703473/017	Office Supplies	10/25/17	\$115.97
U.S. Bank Corporate Payment System	4246044555703473/017	Special Expense	10/25/17	\$47.97
William Mayer	NOV 2017	Expense Report Nov 2017	11/20/17	\$276.00

**Wastewater Sub-Total \$58,018.29**

**Grand Total \$216,685.69**

**Request For Authorization To Pay Invoices (RFA)  
For The Meeting On December 06, 2017  
Town of Discovery Bay, D.Bay L&L Park #8  
For Fiscal Year's 7/17 - 6/18**

<u>Vendor Name</u>	<u>Invoice Number</u>	<u>Description</u>	<u>Invoice Date</u>	<u>Amount</u>
<b>Zone 8</b>				
Cintas	185631186	Uniforms	11/08/17	\$53.11
Cintas	185632179	Uniforms	11/15/17	\$56.25
Comcast	8155400350357156/711	Internet Service	11/15/17	\$172.63
Du-All Safety	19295	Safety Training And Support	10/31/17	\$680.00
Mt. Diablo Resource Recovery	17-0001966/110217	Com 2 Yd Bin	11/02/17	\$318.35
Pacific Gas & Electric	0869258994-1/110817	Electric & Gas Bill	11/08/17	\$503.37
Pacific Gas & Electric	5939734421-5/11417	Electric & Gas Bill	11/14/17	\$8,268.32
Tee Janitorial & Maintenance	9052	Janitorial Service Nov 2017	11/20/17	\$720.00
Town of Discovery Bay, CSD	9-900-000-002-7.02	Water Bill 10/01/17-10/31/17	10/31/17	\$83.65
Town of Discovery Bay, CSD	9-900-000-004-2.01	Water Bill 10/01/17-10/31/17	10/31/17	\$2,083.23
Town of Discovery Bay, CSD	9-900-000-004-2.02	Water Bill 10/01/17-10/31/17	10/31/17	\$830.16
Town of Discovery Bay, CSD	9-900-000-004-2.03	Water Bill 10/01/17-10/31/17	10/31/17	\$293.22
Town of Discovery Bay, CSD	9-900-000-004-2.04	Water Bill 10/01/17-10/31/17	10/31/17	\$223.89
Town of Discovery Bay, CSD	9-900-000-004-2.05	Water Bill 10/01/17-10/31/17	10/31/17	\$69.18
Town of Discovery Bay, CSD	9-900-000-004-2.06	Water Bill 10/01/17-10/31/17	10/31/17	\$272.47
Town of Discovery Bay, CSD	9-900-000-004-2.07	Water Bill 10/01/17-10/31/17	10/31/17	\$46.76
Town of Discovery Bay, CSD	9-900-000-004-2.08	Water Bill 10/01/17-10/31/17	10/31/17	\$46.76
Town of Discovery Bay, CSD	9-900-000-004-2.09	Water Bill 10/01/17-10/31/17	10/31/17	\$107.93
Town of Discovery Bay, CSD	9-900-000-004-2.10	Water Bill 10/01/17-10/31/17	10/31/17	\$145.71
Town of Discovery Bay, CSD	9-900-000-004-4.01	Water Bill 10/01/17-10/31/17	10/31/17	\$44.07
Town of Discovery Bay, CSD	9-900-000-004-4.02	Water Bill 10/01/17-10/31/17	10/31/17	\$115.12
Town of Discovery Bay, CSD	9-900-000-004-4.03	Water Bill 10/01/17-10/31/17	10/31/17	\$415.56
Town of Discovery Bay, CSD	9-900-000-004-4.04	Water Bill 10/01/17-10/31/17	10/31/17	\$15.29
Town of Discovery Bay, CSD	9-900-000-004-4.05	Water Bill 10/01/17-10/31/17	10/31/17	\$29.60
Town of Discovery Bay, CSD	9-900-000-012-0.01	Water Bill 10/01/17-10/31/17	10/31/17	\$29.60
Town of Discovery Bay, CSD	565	Payroll Reimbursement Oct 2017	11/22/17	\$14,322.99
U.S. Bank Corporate Payment System	4246044555703473/017	Vehicle & Equipment Fuel	10/25/17	\$379.42
U.S. Bank Corporate Payment System	4246044555703473/017	Equipment Maintenance	10/25/17	\$311.59
U.S. Bank Corporate Payment System	4246044555703473/017	Misc. Small Tools	10/25/17	\$25.97
U.S. Bank Corporate Payment System	4246044555703473/017	Landscape Maintenance	10/25/17	\$313.48
U.S. Bank Corporate Payment System	4246044555703473/017	Building Maintenance	10/25/17	\$3,557.02
U.S. Bank Corporate Payment System	4246044555703473/017	Personal Protective Equipment	10/25/17	\$248.95
U.S. HealthWorks	3218926-CA	Safety Supplies & Services	10/27/17	\$188.00
United Site Services	114-5972158	Portable Restroom Rental	10/30/17	\$95.83
<b>Total</b>				<b>\$35,067.48</b>
<b>Community Center</b>				
Cintas	185631186	Community Center-Mats, Etc.	11/08/17	\$52.90
Cintas	185632179	Community Center-Mats, Etc.	11/15/17	\$54.28
Comcast	8155400350238372/711	Community Center-Internet Service	11/22/17	\$206.30
Leslie's Pool Supplies, Inc.	27-003-383	Community Center-Pool Chemicals	11/14/17	\$544.22
Lucia Peters	17	Community Center-Program Fees	11/28/17	\$756.00
Monica Gallo	NOV 2017	Community Center-Expense Report Nov 2017	11/03/17	\$79.04
Mt. Diablo Resource Recovery	17-0013218/110217	Community Center-Com 3 Yd Bin	11/02/17	\$444.66
Pacific Gas & Electric	5702839598-6/110817	Community Center-Electric & Gas Bill	11/08/17	\$758.78
Sheredan Hart	NOV 2017	Community Center-Expense Report Nov 2017	11/10/17	\$114.49
Smearad Paint	101317-06	Community Center-Program Fees	07/12/17	\$292.50
Tee Janitorial & Maintenance	9052	Community Center-Janitorial Service Nov 2017	11/20/17	\$260.00
Town of Discovery Bay, CSD	9-900-000-002-6.02	Community Center-Water Bill 10/01/17-10/31/17	10/31/17	\$44.61
Town of Discovery Bay, CSD	9-900-000-002-6.03	Community Center-Water Bill 10/01/17-10/31/17	10/31/17	\$925.44
Town of Discovery Bay, CSD	565	Community Center-Payroll Reimbursement Oct 2017	11/22/17	\$18,617.33
U.S. Bank Corporate Payment System	4246044555703473/017	Community Center-Travel & Meetings	10/25/17	\$65.99
U.S. Bank Corporate Payment System	4246044555703473/017	Community Center-Events	10/25/17	\$402.43
U.S. Bank Corporate Payment System	4246044555703473/017	Community Center-Telephone General	10/25/17	\$397.56
U.S. Bank Corporate Payment System	4246044555703473/017	Community Center-Info System	10/25/17	\$758.88
U.S. Bank Corporate Payment System	4246044555703473/017	Community Center-Monthly Software	10/25/17	\$463.38
U.S. Bank Corporate Payment System	4246044555703473/017	Community Center-Office Supplies	10/25/17	\$43.20
U.S. Bank Corporate Payment System	4246044555703473/017	Community Center-Building Maintenance	10/25/17	\$258.90
United Site Services	114-5972157	Community Center-Portable Restroom Rental	10/30/17	\$266.65
United States Postal Services	2017	Community Center-Postage Activity Guide	11/08/17	\$980.00
Watersavers Irrigation Inc.	1916231-00	Community Center-Landscape Maintenance	11/15/17	\$86.44
<b>Total</b>				<b>\$26,873.98</b>
<b>Grand Total</b>				<b>\$61,941.46</b>

**Request For Authorization To Pay Invoices (RFA)**  
**For The Meeting On December 06, 2017**  
**Town of Discovery Bay, D.Bay L&L Park #9 (Ravenswood)**  
**For Fiscal Year's 7/17 - 6/18**

<u>Vendor Name</u>	<u>Invoice Number</u>	<u>Description</u>	<u>Invoice Date</u>	<u>Amount</u>
Cintas	185631186	Uniforms	11/08/17	\$53.13
Cintas	185632179	Uniforms	11/15/17	\$56.26
Pacific Gas & Electric	0403377952-3/110717	Electric & Gas Bill	11/07/17	\$63.45
Town of Discovery Bay, CSD	9-900-000-004-3.01	Water Bill 10/01/17-10/31/17	10/31/17	\$178.92
Town of Discovery Bay, CSD	9-900-000-004-3.02	Water Bill 10/01/17-10/31/17	10/31/17	\$1,020.02
Town of Discovery Bay, CSD	9-900-000-004-3.03	Water Bill 10/01/17-10/31/17	10/31/17	\$46.76
Town of Discovery Bay, CSD	566	Payroll Reimbursement Oct 2017	11/22/17	\$5,333.04
Tee Janitorial & Maintenance	9052	Janitorial Service Nov 2017	11/20/17	\$280.00
U.S. Bank Corporate Payment System	4246044555703473/017	Telephone General	10/25/17	\$7.65
U.S. Bank Corporate Payment System	4246044555703473/017	Vehicle & Equipment Fuel	10/25/17	\$467.85
U.S. Bank Corporate Payment System	4246044555703473/017	Vehicle Repair & Maintenance	10/25/17	\$30.11
U.S. Bank Corporate Payment System	4246044555703473/017	Landscape Maintenance	10/25/17	\$68.81
			<b>Total</b>	<b>\$7,606.00</b>



# Town of Discovery Bay

*"A Community Services District"*

## STAFF REPORT

**Meeting Date**

December 6, 2017

**Prepared By:** Michael R. Davies, General Manager  
**Submitted By:** Michael R. Davies, General Manager

MRD

**Agenda Title:**

Approve Board and Management Attendance at the 2018 Annual State of the Town Event.

**Recommended Action**

Authorize attendance and payment for the Board of Directors and Town Management to attend the annual "State of the Town Gala" event on Saturday, January 27, 2018.

**Executive Summary**

Each year, the Discovery Bay Chamber of Commerce hosts its annual "State of the Town Gala" Banquet. This year's event will take place at the Discovery Bay Yacht Club on January 27, 2018 at 6:00 P.M.

As in past years, it is customary and appropriate for the Board of Directors and Management staff to attend these types of community/public events. Participation in this event provides a venue for delivering a State of the Town Address, demonstrates community involvement and outreach, allows opportunities for gaining direct feedback, puts faces to names, and gives honor to the Business, Citizen and Teacher of the Year.

The cost to attend is \$85.00 per person. If all five members of the Board and all five Managers attend the total cost will not exceed \$850.00.

**Previous Relevant Board Actions for This Item**

Annual Board attendance since at least 2011.

**Attachments**

2018 State of the Town Gala Invitation.

**AGENDA ITEM: C-3**

*SECRET PASSWORD  
GIVEN UPON REGISTRATION*

*ENJOY SPECIAL DRINKS  
OF THE PERIOD*

# THE BOOTLEGGERS BALL

*A SPEAKEASY STATE OF THE TOWN GALA*

PRESENTED BY THE DISCOVERY BAY CHAMBER OF COMMERCE

JOIN US AS WE HONOR

*BUSINESS OF THE YEAR*

*CITIZEN OF THE YEAR*

*TEACHER OF YEAR*

HELP US CELEBRATE THE CURRENT AND FUTURE  
STATE OF OUR COMMUNITY

*DINNER ● DANCING ● GAMING*

*6PM ● 1.27.18 ● \$85 PER PERSON*

*DRESS OF THE PERIOD OR FORMAL ATTIRE ENCOURAGED*

*DISCOVERY BAY YACHT CLUB*

*A PORTION OF THE PROCEEDS WILL BE DONATED TO*

*BUSD MUSIC & LIBERTY HIGHSCHOOL BAND*

*BEST KEPT SECRET IN THE BAY*

*DISCOVERYBAYCHAMBER.ORG OR CALL 925.240.4144*





# Town of Discovery Bay

*"A Community Services District"*

## STAFF REPORT

Meeting Date

December 6, 2017

**Prepared By:** Michael R. Davies, General Manager  
**Submitted By:** Michael R. Davies, General Manager

MRD

**Agenda Title:**

Approve Board Officers for Calendar Year 2018.

**Recommended Action**

Elect the Board Officers for Calendar Year 2018 consistent with Board Policy 004: Board President - Kevin Graves; Board Vice-President - Bill Mayer; and President Pro-Tempore – Robert Leete.

**Executive Summary**

Yearly the Board of Directors elects a President, Vice-President and President Pro-Tempore. Board Policy 004 (amended February 18, 2015) designates the procedure for electing Board officers for the upcoming 2018 calendar year.

According to Policy 004, the following Directors will serve in calendar year 2018:

Board President: Kevin Graves  
Board Vice-President: Bill Mayer  
President Pro-Tempore: Robert Leete

**Previous Relevant Board Actions for This Item**

January 4, 2017 - Board Officers for Calendar Year 2017

**Attachments**

Board Policy 004 (Amended 2/18/15)

AGENDA ITEM: C-4



# Town of Discovery Bay

<b>Program Area:</b> Board	<b>Policy Name:</b> Board Policy	<b>Policy Number:</b> 004
<b>Date Established:</b> June 19, 2002	<b>Date Amended:</b> February 18, 2015	<b>Resolution:</b> 2015-03

## PURPOSE

The purpose of the elected Board of Directors of the Town of Discovery Bay, a multipurpose independent special district, is to represent the residents within its boundaries in any and all matters covered under the California Government Code relating to a Community Services District.

In addition to the purposes listed in the Government Code, the District has been ordered by LAFCO and the Board of Supervisors to perform an advisory role for the residents of Discovery Bay. This role includes, but is not limited to, advising the County in matters of land use planning, zoning, compliance, roads and streets, lighting, landscaping, parks and public safety services.

### I. BOARD OF DIRECTORS

The governing body of the Town of Discovery Bay is a Board of Directors comprised of five (5) Board members elected by the registered voters of the District to serve four (4) year staggered terms. During the elections every two (2) years, either two (2) or three (3) Directors are elected to serve the District for the next four (4) years.

Yearly the Board of Directors elects a President, Vice-President and President Pro-Tempore. The President of the Board chairs the meeting, performs such duties as prescribed by State or Federal law and such other duties as prescribed by Board Policy or the established Bylaws of the Town of Discovery Bay. In the event of the President's absence, the Vice-President performs said duties. In the event of the President and Vice-President's absence, the President Pro-Tempore performs said duties.

The appointment of Board officers shall be established based upon the following schedule and shall become effective in January 2016:

#### **Board President**

In order to be considered to serve as President of the Board, the Board member must have served on the Board for a minimum 24 months prior to being considered for rotation into the Board President position. The Board Presidency shall be assigned to the Board member who has not served as President and who has met the 24 month requirement.

If more than one Board member has met the 24 month requirement and not served as President, the member with the longest tenure on the Board of Directors shall be the first person appointed to the position of President.

In the event each member of the Board has previously served as President at one point in their respective office, the Board member to serve as Board President shall be the member who has not served as President for the longest period time.

In the event seniority cannot be determined due to the date of assumption of office, the Board member with the highest vote count in their most recent election shall prevail as the senior member for purposes of this selection procedure.

### **Vice President**

The Vice President shall be the Director next in line to be President based on the then current service time. In order for a Board member to be considered for the position of Vice President, the Board member must have served on the Board for a minimum of 12 months prior to being considered for rotation into the Board Vice President position. The Board Vice President shall be assigned to the Board member who has not served as Vice President and who has met the minimum 12 month service requirement.

In the event seniority cannot be determined due to the date of assumption of office, the Board member with the highest vote count in their most recent election shall prevail as the senior member for purposes of this selection procedure.

### **President Pro-Tempore**

The President Pro-Tempore shall be the Director next in line to be Vice President based on the then current service time. In order for a Board member to be considered for the position of President Pro Tempore, the Board member must have served on the Board for a minimum of 12 months prior to being considered for rotation into the Board President Pro Tempore position. The Board President Pro Tempore shall be assigned to the Board member who has not served as President Pro Tempore and who has met the minimum 12 month service requirement.

In the event seniority cannot be determined due to the date of assumption of office, the Board member with the highest vote count in their most recent election shall prevail as the senior member for purposes of this selection procedure.

## **II. POWER OF THE BOARD**

The Board of Directors recognizes its duty to formulate and approve the policy program for the operation, control, administration and planning of the District's facilities and activities of the District.

Board meetings shall be noticed and shall take place pursuant to the Ralph M Brown Act of 1953, as amended (hereafter, Brown Act).

The parliamentary procedure for conducting all meetings will be Rosenberg's Rules of Order.



The Board meets its obligations to the electorate by performing as a legislative, administrative and control body.

The Board may have standing committees and may appoint ad hoc committees as the need arises. The District's General Manager or Designee may serve as staff support to those committees.

In the discharge of their duties, Directors shall comply with all applicable local, state and federal laws, including ethics trainings as required by AB1234.

### **III. RESPONSIBILITIES**

#### **A. Responsibilities of the Board of Directors:**

1. To select a General Manager as the Board's chief administrative officer and professional advisor and properly delegate to him or her the authority and responsibility to execute its' policies, enforce its rules and regulations, and administer the facilities, programs, and services of the District. Provide the General Manager with the necessary personnel and resources to carry out his or her responsibilities.
2. To adopt a District budget that provides the best possible facilities, programs, and services, within the limits of fiscal responsibility, to the people of the District.
3. To adopt a comprehensive set of Board policies and administrative procedures to govern the operation of the District. These policies and procedures shall be amended and revised as appropriate and shall be compiled and published in a Board Policies Manual. The District shall keep at its offices a master copy of such manual, which shall be kept for all purposes the official record of the Board policies of the District.
4. By motion, resolution, or ordinance conduct the business of the District, taking those actions that ensure that satisfactory services are provided throughout the community.
5. Keep informed on agenda items and on-going business of the Board.
6. Be well informed on the provisions of laws, ordinances and resolutions as they affect conduct of the District and the Board.
7. Attend meetings with promptness and regularity.
8. Elect officers and confirm standing and ad hoc committee members and District representatives to external agencies.
9. Initiate, review and approve plans that will satisfy future requirements, including a long-range plan (five (5) to ten (10) years).
10. Review and act upon plans and recommendations submitted by the Board committees and the General Manager. This action includes adoption, rejection, amendment or return to committee.

11. Single Board members will not represent the whole of the Board in other open or closed meetings without prior sanction by the majority direction of the Board.

**B. GENERAL CONDUCT OF BOARD OF DIRECTORS AND OFFICERS**

**1. No member of the Board or Officers of the District shall:**

- a. Represent his or her position as that of the Board unless the Board has acted upon that position.
- b. Make unsolicited statements to anyone other than the Board during Board deliberations.
- c. Issue any writings or statements to the press or public without clearly distinguishing which statements are his or her own and which are established Board positions.

**2. Preparation and Commitment:**

- a. Shall respect the Board's commitment to work through the General Manager by requesting desired information about the District's programs/activities directly from him/her, by referring to him/her suggestions for new policies, for his/her professional advice, by refraining from acting on any complaint until after the General Manager has had an opportunity to investigate fully and report to the Board, and by wholeheartedly supporting Board approved actions of the General Manager and his/her staff.
- b. Accept the principle of Board unity or consensus by supporting majority decisions of the Board.
- c. Shall make decisions involving the welfare of the District based on factual information and evidence recognizing that personal feelings, opinions and other such factors are not conducive to sound decision making.
- d. Come prepared, ready to ask questions and make decisions.
- e. Do what is agreed upon.
- f. Respect confidentiality of Closed Session agenda items.
- g. Contact the General Manager prior to meeting for more information, if needed.

**C. ADDITIONAL RESPONSIBILITIES OF THE BOARD MEMBERS**

**1. Orientation of Board Members**

- a. The Board of Directors recognizes its responsibility in helping and assisting a newly elected or appointed Board member to understand the operation of the District as well as the roles and responsibilities of a member of the Board. The Board and General Manager shall assist each new member-elect to understand the Board functions, policies, procedures, roles, duties and responsibilities of members of the Board. The following methods shall be employed:

- b. The new member shall be given selected material on the duties and responsibilities associated with Board membership. These materials shall include, but are not limited to: The Government Code dealing with Community Services Districts, the Ralph M. Brown Act, the California Public Records Act, Board Policies, and any pertinent publications issued by the California Special Districts Association, the California Parks and Recreation Society and other agencies, as needed.
- c. As soon as practical after the new Board member assumes office, an orientation meeting with General Manager will be held prior to the first Board meeting to acquaint the new member with details of District operations.
- d. The incoming member may meet with the General Manager and members of his staff to discuss services they perform for the Board and the District.

## **2. Policy Violations**

- a. Board Members who intentionally or repeatedly do not comply with this Policy may be reprimanded or formally censured by the Board of Directors.

## **D. Responsibilities of a Committee Chairperson**

1. Undertake the specific tasks or assignments as established by the Board or Board President together with the participation of the other members of the committee.
2. Plan and schedule the necessary activities and obtain commitments for the necessary resources to complete the assignment.
3. Present a report on status and progress to the Board at appropriate times as designated by the President.
4. Prepare recommendations and justification for any proposed action and submit to the Board for decision and implementation when approved.
5. Provide overall leadership of the committee.
6. Perform the duties of a Board member if appropriate.



# Town of Discovery Bay

*"A Community Services District"*

## STAFF REPORT

**Meeting Date**

December 6, 2017

**Prepared By:** Michael R. Davies, General Manager  
**Submitted By:** Michael R. Davies, General Manager

MRD

**Agenda Title:**

Discussion and possible action regarding cancellation of Regular Board Meeting.

**Recommended Action**

Approve the recommendation from the Internal Operations Committee to cancel the Regular Board Meeting of January 3, 2018.

**Executive Summary**

Each year the Town of Discovery Bay offices are closed for the Holiday Season. This year, the closure is Friday, December 22, 2017 through January 1, 2018. If the January 3, 2018 Regular Board Meeting takes place, staff will not have returned to work in time to prepare and post the Agenda 72 hours prior to the meeting. The alternative is to prepare and post the Agenda on Thursday, December 21, 2017, which is the next day after the Board Meeting of December 20, 2017. It is not likely that significant Board business would develop the day after a Board Meeting.

Refer chart below for dates TODB offices are open and closed.

DECEMBER 2017 / JANUARY 2018						
Sunday	Monday	Tuesday	Wednesday	Thursday	Friday	Saturday
17	18 OPEN	19 OPEN	20 Board Meeting	21 OPEN	22 CLOSED	23 CLOSED
24 CLOSED	25 CLOSED	26 CLOSED	27 CLOSED	28 CLOSED	29 CLOSED	30 CLOSED
31 CLOSED	1 CLOSED	2 OPEN	3 Board Meeting	4 OPEN	5 OPEN	6

This matter was considered at the Internal Operations Committee Meeting on November 16, 2017. The recommendation from the Internal Operations Committee is to CANCEL the Regular Board Meeting of January 3, 2018. The next Regular Board Meeting would take place on January 17, 2018.

**Previous Relevant Board Actions for This Item**

**Attachments**

None

**AGENDA ITEM: G-1**



# Town of Discovery Bay

*"A Community Services District"*

## STAFF REPORT

Meeting Date

December 6, 2017

**Prepared By:** Dina Breitstein, Finance Manager  
**Submitted By:** Michael R. Davies, General Manager

MRD

### Agenda Title

Discussion and possible action regarding the Electronic Check Signature Process.

### Recommended Action

Authorize staff to implement automated check signing and approval process.

### Executive Summary

Our current Financial Software, Caselle has the ability to add signatures to checks being printed to pay for invoices. This eliminates the need for the Board Members to hand sign individual checks to pay for invoices at each board meeting.

The automated signatures would be the current Board President and the current Board Vice President. Concurrently, with this new automated check signing system staff has implemented a new approval procedure.

The approval procedure includes:

- The Five Board Members will approve the Request For Approval (RFA) provided in the board packet,
- Two Board Members will review the Check Register Form (this form lists all checks being approved on the RFA) and attached are the associated check stubs,
- The Check Register Form requires the signature approval of two Board Members,
- The signed Check Register Form is returned back to the District office and given to staff who will then review the register and the checks before mailing them out.

The planned start date for this process is January 2018.

### Fiscal Impact:

Amount Requested \$0  
Sufficient Budgeted Funds Available?  
Prog/Fund #

### Previous Relevant Board Actions for This Item -

### Attachments

None

AGENDA ITEM: G-2



# Town of Discovery Bay

*"A Community Services District"*

## STAFF REPORT

**Meeting Date**

December 6, 2017

**Prepared By:** Michael R. Davies, General Manager  
**Submitted By:** Michael R. Davies, General Manager

MRD

**Agenda Title:**

Discussion and possible action regarding the Annual Board Workshop for 2018.

**Recommended Action**

Set date and time for 2018 Annual Board Workshop. Staff recommendation is March 1, 2018 at 4:00 P.M.

**Executive Summary**

Each year the Board schedules an interactive workshop with staff to review Town accomplishments and future direction.

In 2017, the annual Board Workshop was held Thursday evening, February 2, 2017 at 6:30 P.M. The workshop lasted two (2) hours.

Attached are calendars for February and March 2018 for your reference.

Staff recommends Thursday, March 1, 2018 at 4:00 P.M. as there are no Board or Committee Meetings scheduled during that week.

**Previous Relevant Board Actions for This Item**

February 2, 2017 Annual Board Workshop for 2017

**Attachments**

Reference calendars for February and March 2018.

**AGENDA ITEM: G-3**

# February 2018

February 2018						
Su	Mo	Tu	We	Th	Fr	Sa
				1	2	3
4	5	6	7	8	9	10
11	12	13	14	15	16	17
18	19	20	21	22	23	24
25	26	27	28			

March 2018						
Su	Mo	Tu	We	Th	Fr	Sa
				1	2	3
4	5	6	7	8	9	10
11	12	13	14	15	16	17
18	19	20	21	22	23	24
25	26	27	28	29	30	31

SUNDAY	MONDAY	TUESDAY	WEDNESDAY	THURSDAY	FRIDAY	SATURDAY
Jan 28	29	30	31	Feb 1	2	3
4	5 Mike Davies Teaching	6	7 5:30pm Communications Committee Meeting 7:00pm TODB Regular Board Meeting	8 4:00pm Internal Operations Committee Meeting (Community Center)	9	10
11	12	13	14	15 4:00pm Copy: Water and Wastewater Standing Committee Meeting (1601 Discovery Bay)	16	17
18	19	20	21 3:30pm Copy: Parks and Recreation Standing Committee Meeting 7:00pm TODB Regular Board Meeting	22	23	24
25	26	27	28	Mar 1	2	3

# March 2018

March 2018						
Su	Mo	Tu	We	Th	Fr	Sa
4	5	6	7	8	9	10
11	12	13	14	15	16	17
18	19	20	21	22	23	24
25	26	27	28	29	30	31

April 2018						
Su	Mo	Tu	We	Th	Fr	Sa
1	2	3	4	5	6	7
8	9	10	11	12	13	14
15	16	17	18	19	20	21
22	23	24	25	26	27	28
29	30					

SUNDAY	MONDAY	TUESDAY	WEDNESDAY	THURSDAY	FRIDAY	SATURDAY
Feb 25	26	27	28	Mar 1	2	3
4	5	6	7 7:00pm TODB Regular Board Meeting (Community Center)	8	9	10
11	12	13	14	15 4:00pm Copy: Water and Wastewater Standing Committee Meeting (1601 Discovery Bay)	16	17
18	19	20	21 7:00pm TODB Regular Board Meeting (Community Center)	22	23	24
25	26	27	28	29	30	31





# Town of Discovery Bay

*"A Community Services District"*

## STAFF REPORT

Meeting Date

December 6, 2017

**Prepared By:** Carol McCool, Administrative Assistant  
**Submitted By:** Michael R. Davies, General Manager

MRD

### Agenda Title

Discussion and possible action regarding the Agency Comment Request – Land Use Permit/Development Plan Application LP17-2027 – Upgrades to the Existing McDonald's.

### Recommended Action

Authorize the General Manager to complete and sign the "Agency Comment Request" indicating no comments to the plan.

### Executive Summary

The Contra Costa County Department of Conservation and Development has requested input regarding the proposed Development Plan Application LP17-2027 for the Existing McDonald's. The applicant is requesting to make improvements to the existing McDonald's located at 14896 Highway 4 in Discovery Bay.

Those improvements will include upgrading the interior and exterior lighting and signage; replacement of metal canopies, new interior dining room finishes, ADA upgrades to the restroom and parking lot, along with new Drive-Through equipment.

Staff has reviewed the plans and noted what appears to be a change in roof line and color scheme that would be different than the surrounding buildings in the shopping center. Staff considers the proposed exterior change to be a modernization, even though it contrasts with the other buildings.

Staff has no significant concerns with the project.

### Fiscal Impact:

Amount Requested \$ N/A

Sufficient Budgeted Funds Available?: (If no, see attached fiscal analysis)

Prog/Fund # Category: Pers. Optg. Cap. -or- CIP# Fund#

### Previous Relevant Board Actions for This Item

### Attachments

Agency Comment Request – Development Plan Application LP17-2027

AGENDA ITEM: G-4



TownOfDiscoveryBay CSD  
 Received  
 NOV 20 2017

11/16/17  
 (7) (SW)

**AGENCY COMMENT REQUEST**

Date 11/15/17

We request your comments regarding the attached application currently under review.

*DISTRIBUTION*

Internal

Building Inspection      \_\_\_ Grading Inspection  
 \_\_\_ Advance Planning      \_\_\_ Housing Programs  
 \_\_\_ Trans. Planning      \_\_\_ Telecom Planner  
 \_\_\_ ALUC Staff      \_\_\_ HCP/NCCP Staff  
 \_\_\_ APC Floodplain Tech      \_\_\_ County Geologist

Health Services Department

Environmental Health      \_\_\_ Hazardous Materials

Public Works Department

Engineering Services (Full-size)      \_\_\_ Traffic  
 \_\_\_ Flood Control (Full-size)      \_\_\_ Special Districts

Local

Fire District EAST CONTRA COSTA  
 \_\_\_ Consolidated - (email) fire@cccfd.org

\_\_\_ Sanitary District \_\_\_\_\_  
 \_\_\_ Water District \_\_\_\_\_  
 \_\_\_ City of \_\_\_\_\_  
 \_\_\_ School District(s) \_\_\_\_\_  
 \_\_\_ LAFCO \_\_\_\_\_  
 \_\_\_ Reclamation District # \_\_\_\_\_  
 \_\_\_ East Bay Regional Park District \_\_\_\_\_  
 Diablo/Discovery Bay/Crockett CSD  
 \_\_\_ MAC/TAC \_\_\_\_\_  
 \_\_\_ Improvement/Community Association \_\_\_\_\_  
 CC Mosquito & Vector Control Dist (email)

Others/Non-local

\_\_\_ CHRIS - Sonoma State \_\_\_\_\_  
 \_\_\_ CA Fish and Wildlife, Region 3 - Bay Delta \_\_\_\_\_  
 \_\_\_ Native American Tribes \_\_\_\_\_

Additional Recipients

District 3

Please submit your comments to:

Project Planner Sean Tully  
 Phone # 925-674-7800  
 E-mail Sean.Tully@dcd.cccounty.us  
 County File # 1817-2027

Prior to December 13, 2017

\*\*\*\*\*

We have found the following special programs apply to this application:

\_\_\_ Active Fault Zone (Alquist-Priolo)  
 \_\_\_ Flood Hazard Area, Panel # \_\_\_\_\_  
 \_\_\_ 60-dBA Noise Control  
 \_\_\_ CA EPA Hazardous Waste Site

\*\*\*\*\*

**AGENCIES:** Please indicate the applicable code section for any recommendation required by law or ordinance. Please send copies of your response to the Applicant and Owner.

Comments: \_\_\_ None \_\_\_ Below \_\_\_ Attached

\_\_\_\_\_  
 \_\_\_\_\_  
 \_\_\_\_\_  
 \_\_\_\_\_  
 \_\_\_\_\_  
 \_\_\_\_\_  
 \_\_\_\_\_  
 \_\_\_\_\_  
 \_\_\_\_\_  
 \_\_\_\_\_

Print Name \_\_\_\_\_

Signature \_\_\_\_\_ DATE \_\_\_\_\_

Agency phone # \_\_\_\_\_



**CONTRA COSTA COUNTY**  
 Department of Conservation & Development  
 Community Development Division

PLANNER ASSIGNED

DEVELOPMENT PLAN APPLICATION				
TO BE COMPLETED BY OWNER OR APPLICANT				
<b>PROPERTY OWNER(S)</b>		<b>APPLICANT</b>		
Name <u>PACIFIC DEVELOPMENT GROUP (PDG)</u>		Name <u>BILL GORYL (AECOM)</u>		
Address <u>P.O. Box 3060</u>		Address <u>300 CALIFORNIA ST., SUITE 600</u>		
City, State/Zip <u>NEWPORT BEACH, CA 92658</u>		City, State/Zip <u>SAN FRANCISCO, CA 94104</u>		
Phone <u>(949) 760-8591</u> email		Phone <u>415-908-6104</u> email <u>bill.goryl@aecom.com</u>		
By signing below, owner agrees to pay all costs, including any accrued interest, if the applicant does not pay costs. <input type="checkbox"/> Check here if billings are to be sent to applicant rather than owner. Owner's Signature _____		By signing below, applicant agrees to pay all costs for processing this application plus any accrued interest if the costs are not paid within 30 days of invoicing.  Applicant's Signature <u>Bill Goryl</u>		
<b>CONTACT PERSON (optional)</b>		<b>PROJECT DATA</b>		
Name _____		Total Parcel Size: <u>34846 SF - PART OF SHOPPING CENTER</u>		
Address _____		Proposed Number of Units: <u>—</u>		
City, State/Zip _____		Proposed Square Footage: <u>3696 SF (EXISTING)</u>		
Phone _____ email _____		Estimated Project Value: <u>\$ 757,000</u>		
Project description (attach supplemental statement if necessary): <u>INTERIOR &amp; EXTERIOR LIGHTING &amp; SIGNAGE UPGRADES. REPLACEMENT OF EXISTING METAL CANOPIES. NEW INTERIOR (DINING RM) FINISHES &amp; RESTROOM ADA UPGRADES. - EXISTING MCDONALDS RESTAURANT.</u>				
↓ FOR OFFICE USE ONLY ↓				
Project description: <u>THE APPLICANT REQUESTS APPROVAL OF A LAND USE PERMIT/DEVELOPMENT PLAN COMBINATION PERMIT TO MODIFY COUNTY FILE # LP02-2039 TO ALLOW INTERIOR AND EXTERIOR LIGHTING AND SIGNAGE UPGRADES, REPLACEMENT OF EXISTING METAL CANOPIES, NEW INTERIOR DINING ROOM FINISHES, NEW ADA UPGRADES IN RESTROOM AND PARKING LOT, AND NEW DRIVE-THROUGH EQUIPMENT FOR AN EXISTING MCDONALDS IN THE SANDY LOVE SHOPPING CENTER.</u>				
Property description: <u>LOT-6 OF TRACT 8456</u>				
Ordinance Ref.:	<b>TYPE OF FEE</b>	<b>FEE</b>	<b>CODE</b>	Assessor's #: <u>011-470-006</u>
Area: <u>Discovery Bay</u>	*Base Fee/Deposit	<u>\$4,900.00</u>		Site Address: <u>14896 Highway 4</u>
Fire District: <u>EAST CONTRA COSTA FIRE</u>	Late Filing Penalty (+50% of above if applicable)		S-066	Zoning District: <u>P-1</u>
Sphere of Influence: <u>N/A</u>	#Units _____ x \$195.00		S-014	Census Tract:
Flood Zone: <u>A</u>	Sq. Ft. x \$0.20			Atlas Page: <u>P-28</u>
Panel Number:	Notification Fee	<u>15.00 / 30.00</u>	S-052	General Plan: <u>C0</u>
x-ref Files: <u>LP02-2039</u>	Fish & Game Posting (if not CEQA exempt)	<u>75.00</u>	S-048	Substandard Lot: YES <input type="checkbox"/> NO <input checked="" type="checkbox"/>
<u>DP01-3032</u>	Environmental Health Dept.	<u>57.00</u>	5884	Supervisory District: <u>3</u>
	Other:			Received by: <u>Syd Wayman</u>
Concurrent Files:	<b>TOTAL</b>	<u>\$4,987.00</u>		Date Filed: <u>10/31/2017</u>
	<b>Receipt</b>	<u># 170014869</u> <u># 170014867</u>		File # <u>LP17-2027</u>
*Additional fees based on time and materials will be charged if staff costs exceed base fee.				

**INSTRUCTIONS ON REVERSE**

2003 ROLL-TRACT 8456 M.B. 446-43 (SANDY COVE)

22



BIXLER RD

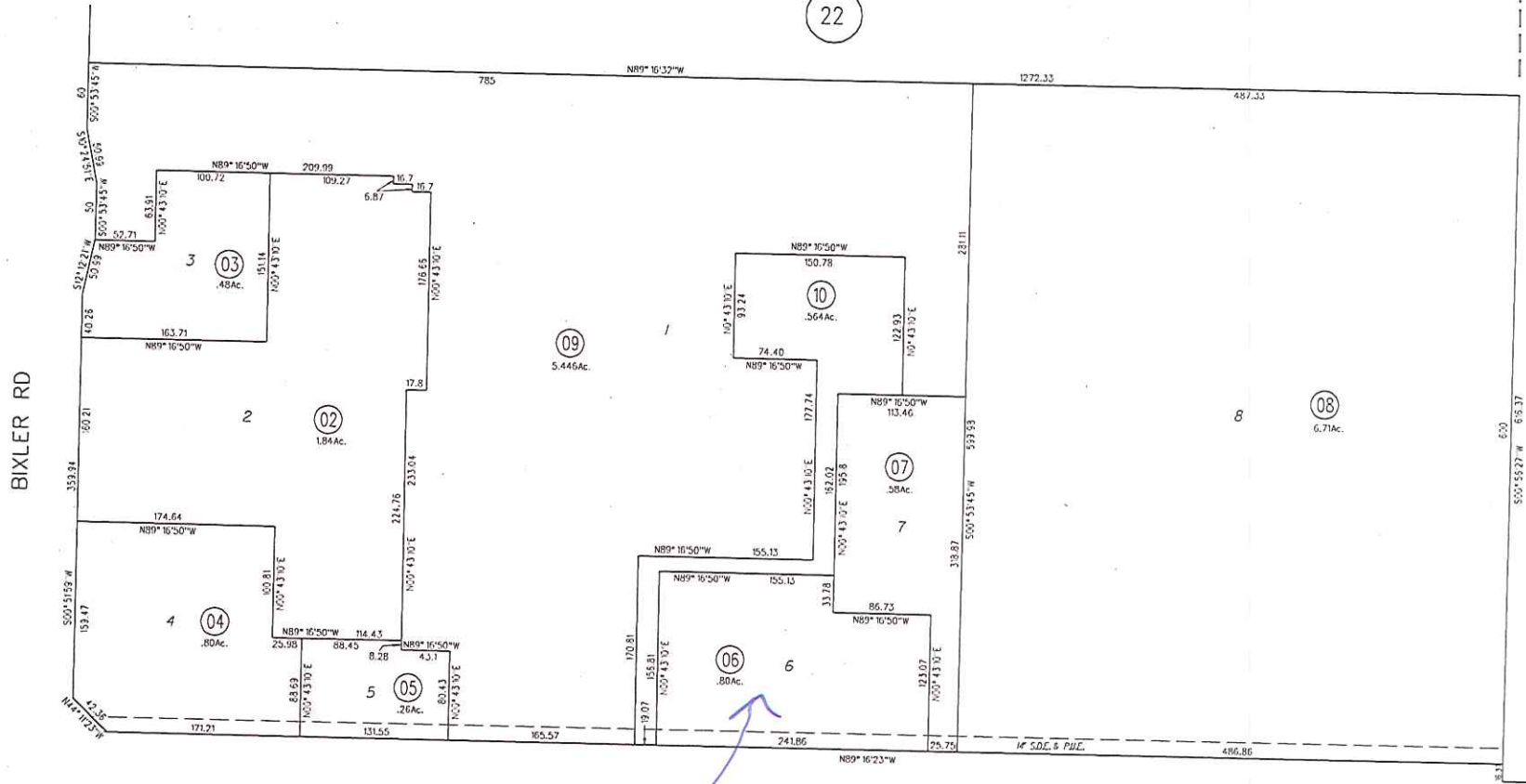

SITE  
HWY 4

BK  
09

470

10

8/18/03

21

NOTE: THIS MAP WAS PREPARED FOR ASSESSMENT PURPOSES ONLY. NO LIABILITY IS ASSUMED FOR THE ACCURACY OF THE INFORMATION DELINEATED HEREON. ASSESSOR'S PARCELS MAY NOT COMPLY WITH LOCAL LOT SPLIT OR BUILDING SITE ORDINANCES.

Map Title

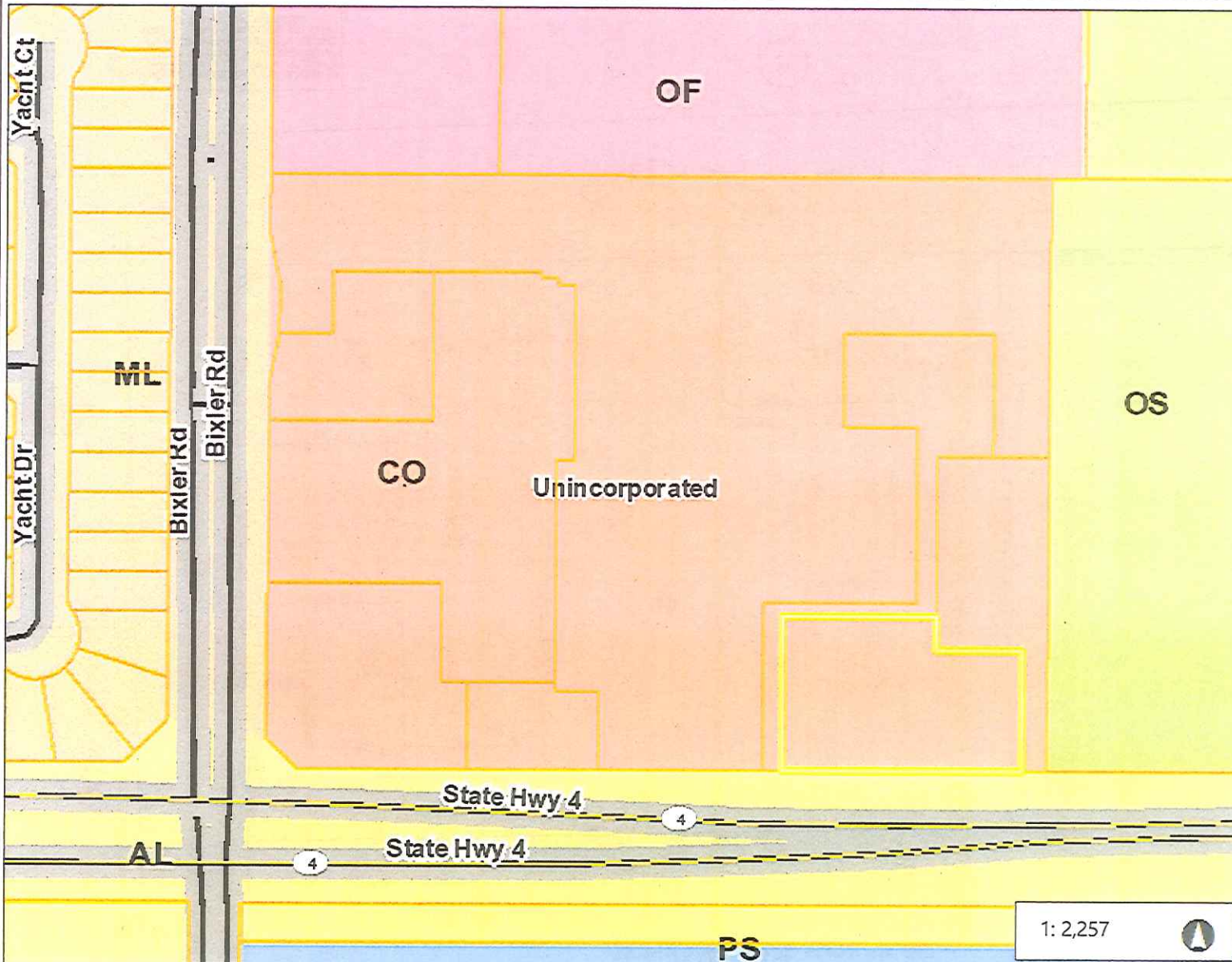

Legend

- Assessor Parcels
- City Limits
- Unincorporated
- Highways
- Highways Bay Area
- Streets
- General Plan
  - SV (Single Family Residential - Ver
  - SL (Single Family Residential - Low
  - SM (Single Family Residential - Me
  - SH (Single Family Residential - Hig
  - ML (Multiple Family Residential - Lc
  - MM (Multiple Family Residential - M
  - MH (Multiple Family Residential - H
  - MV (Multiple Family Residential - V
  - MS (Multiple Family Residential - V
  - CC (Congregate Care/Senior Housi
  - MO (Mobile Home)
  - M-1 (Parker Avenue Mixed Use)
  - M-2 (Downtown/Waterfront Rodeo I
  - M-3 (Pleasant Hill BART Mixed Use
  - M-4 (Willow Pass Road Mixed Use)
  - M-5 (Willow Pass Road Commerci
  - M-6 (Bay Point Residential Mixed L
  - M-7 (Pittsburg/Bay Point BART Sta
  - M-8 (Dougherty Vallejo Villace Cent

Notes

Contra Costa County -DOIT GIS

0.1 0 0.04 0.1 Miles

WGS\_1984\_Web\_Mercator\_Auxiliary\_Sphere

This map is a user generated static output from an Internet mapping site and is for reference only. Data layers that appear on this map may or may not be accurate, current, or otherwise reliable.

THIS MAP IS NOT TO BE USED FOR NAVIGATION

Map Title

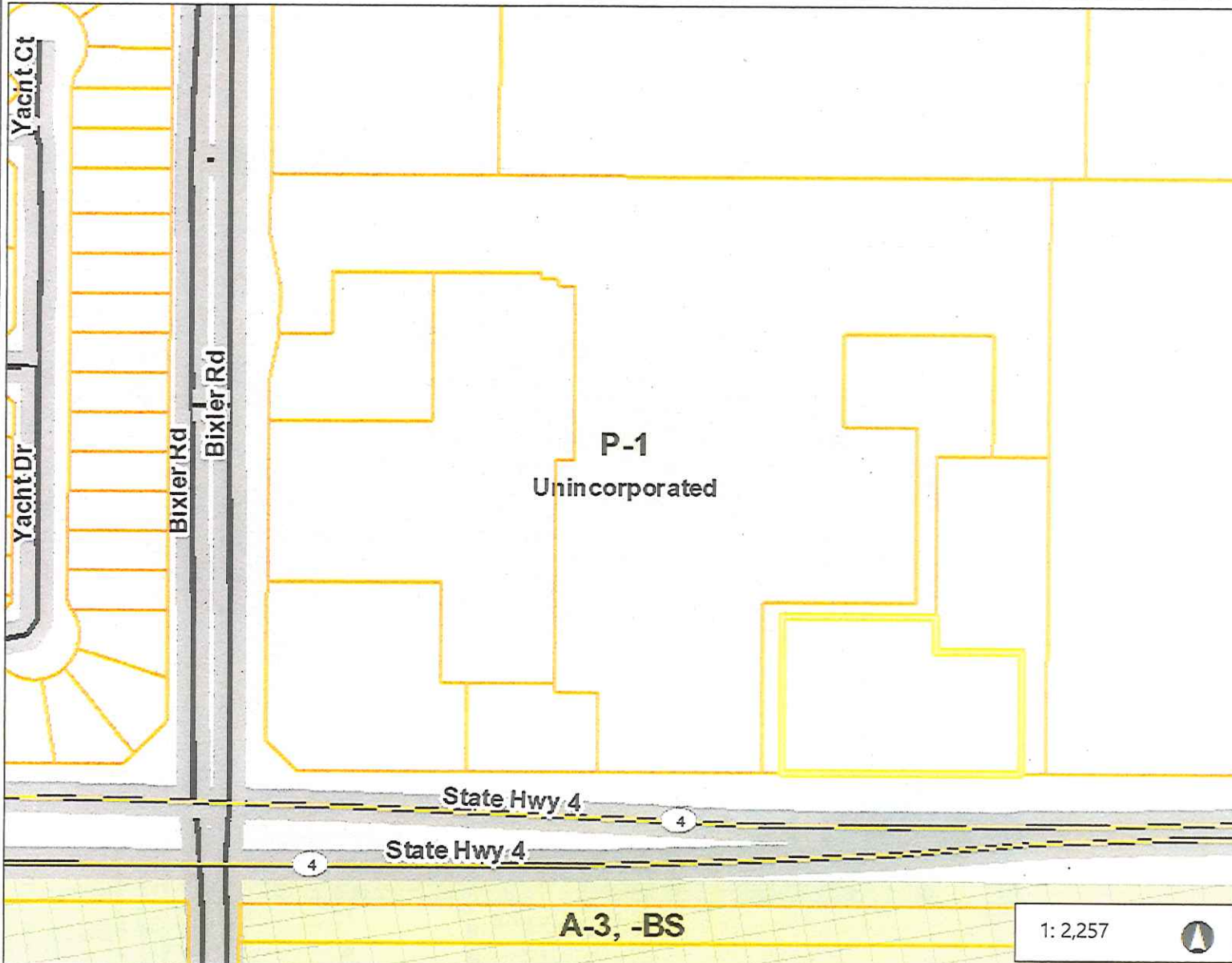

Legend

- Assessor Parcels
- City Limits
- Unincorporated
- Highways
- Highways Bay Area
- Streets
- Zoning
  - R-6
  - R-6 -FH
  - R-6 -SD-1
  - R-6 -TOV -K
  - R-6 -X
  - R-7
  - R-7 -X
  - R-10
  - R-12
  - R-15
  - R-20
  - R-40
  - R-40 -FH
  - R-65
  - R-100
  - D-1
  - D-1 -T
  - M-12
  - M-12 -FH

Notes

Contra Costa County -DOIT GIS

0.1 0 0.04 0.1 Miles

WGS\_1984\_Web\_Mercator\_Auxiliary\_Sphere

This map is a user generated static output from an Internet mapping site and is for reference only. Data layers that appear on this map may or may not be accurate, current, or otherwise reliable.

THIS MAP IS NOT TO BE USED FOR NAVIGATION

1:2,257



Map Title

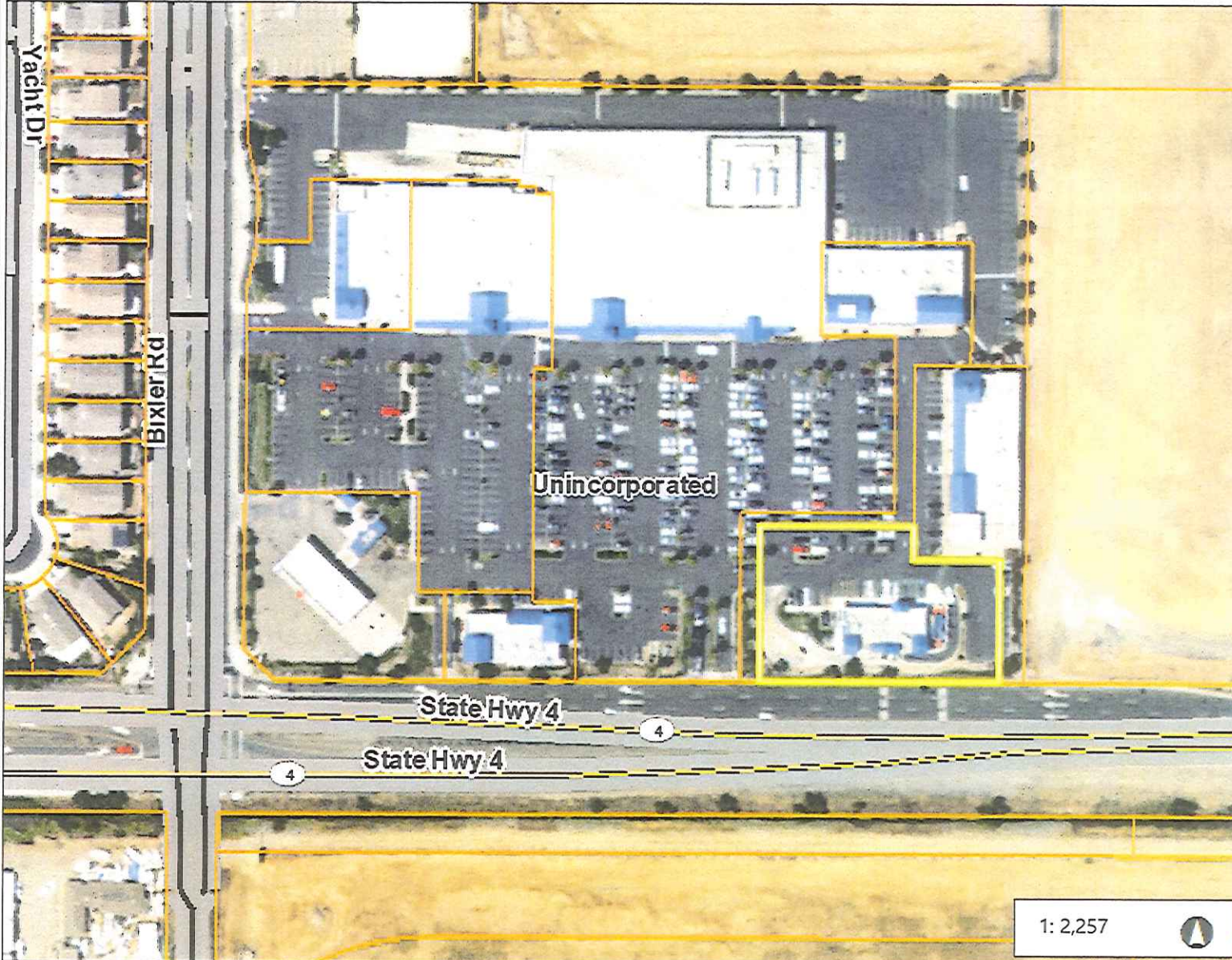

Legend

- Assessor Parcels
- City Limits
- Unincorporated
- Highways
- Highways Bay Area
- Streets
- Water Bodies
- County Boundary
- Bay Area Counties
- World Imagery
- Low Resolution 15m Imagery
- High Resolution 60cm Imagery
- High Resolution 30cm Imagery
- Citations

Notes

Contra Costa County -DOIT GIS

0.1 0 0.04 0.1 Miles

WGS\_1984\_Web\_Mercator\_Auxiliary\_Sphere

This map is a user generated static output from an Internet mapping site and is for reference only. Data layers that appear on this map may or may not be accurate, current, or otherwise reliable.

THIS MAP IS NOT TO BE USED FOR NAVIGATION

**GENERAL NOTES**

- A. DIMENSIONS AND RADI SHOWN ARE TO FLOWLINE UNLESS OTHERWISE STATED.
- B. ALL CURBS ARE 6" AND SHALL BE POURED MONOLITHICALLY WITH CONCRETE PAVEMENT.
- C. VERIFY IN FIELD ALL LOCATIONS AND DIMENSIONS AND RESOLVE ANY DISCREPANCIES WITH MCDONALD'S PROJECT MANAGER PRIOR TO COMMENCING WORK.
- D. COORDINATE ALL DRIVE-THRU STRIPING AND MARKINGS WITH THE MCDONALD'S PROJECT MANAGER.
- E. CONCRETE SHALL BE 6" MIN THICKNESS AND 4000 PSI STRENGTH AT 28 DAYS. PROVIDE #4 REINFORCEMENT AT 12" O.C. AND SAUCUT JOINTS IN CONCRETE PAVEMENT IN ACCORDANCE WITH ACI STANDARDS.
- F. COORDINATE GROUND COVER OF NEW ISLANDS WITH MCDONALD'S PROJECT MANAGER.
- G. ALL SITE WORK INCLUDING BUT NOT LIMITED TO ASPHALT OVERLAY, SUBGRADE PREPARATION AND CAST IN PLACE CONCRETE SHALL BE IN ACCORDANCE WITH MCDONALD'S CONSTRUCTION SPECIFICATIONS.
- H. MAINTAIN EXISTING DRAINAGE PATTERNS WITH NEW CONSTRUCTION.

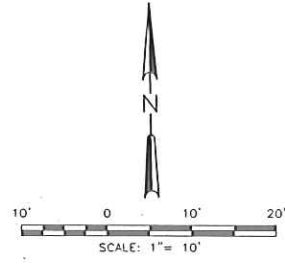

**SCHEDULE #**

- NOTE: NOT ALL NOTES ARE USED ON PLAN
1. EXISTING MCDONALD'S BUILDING, 3,290 SQ. FT.
  2. RESTRIPE PARKING SPACES WITH 4" WIDE PARKING STALL STRIPING
  3. INSTALL 6" CONCRETE SLAB REINFORCED W/ FIBERWESH WITH A 2% MAX SLOPE IN ALL DIRECTIONS. IDEAL SLOPE IS 1.5%. RESTRIPE ADA ACCESS BLUE BORDERS WITH WHITE DIAGONALS. PLACE WALL-MOUNTED HANDICAP SIGNS, STRIPING, AND WHEEL STOPS PER DETAILS (1, 2, 3, 4, 5, 6, 7, 8, 9, 10, 11, 12, 13, 14, 15, 16, 17, 18, 19, 20, 21, 22, 23, 24, 25, 26, 27, 28)
  4. WIDEN CURB RAMP LANDING AREA TO 5' AND INSTALL TRUNCATED DOMES. VERIFY EX. CURB RAMP MEETS ADA SLOPE AND WIDTH REQUIREMENTS (2, 3, 4, 5, 6, 7, 8, 9, 10, 11, 12, 13, 14, 15, 16, 17, 18, 19, 20, 21, 22, 23, 24, 25, 26, 27, 28)
  5. STRIPING AND PAVEMENT MARKINGS TO BE INSTALLED AS SHOWN ON THE PLAN PER DETAILS (1, 2, 3, 4, 5, 6, 7, 8, 9, 10, 11, 12, 13, 14, 15, 16, 17, 18, 19, 20, 21, 22, 23, 24, 25, 26, 27, 28)
  6. LOOP DETECTORS PER DETAILS. CENTERLINE OF PRIMARY COO IS TO BE 15' BEHIND THE TIP OF THE CURB ISLAND. SECONDARY COO IS TO BE MIN. 14' BEHIND THE TIP OF THE CURB ISLAND. (1, 2, 3, 4, 5, 6, 7, 8, 9, 10, 11, 12, 13, 14, 15, 16, 17, 18, 19, 20, 21, 22, 23, 24, 25, 26, 27, 28)
  7. PRIMARY DIGITAL MENUBOARD. THE ENDS OF THE MENU BOARDS SHALL BE 18"-24" FROM THE FACE OF CURB. ANGLE RANGE SHALL BE 25°-35° FOR MAXIMUM VISIBILITY TO DRIVER. THE CENTER OF THE MENU BOARD FOUNDATION IS TO BE 5'-3" (5'-0" MIN AND 6'-0" MAX) FROM THE CENTER OF THE COO FOUNDATION. (1, 2, 3, 4, 5, 6, 7, 8, 9, 10, 11, 12, 13, 14, 15, 16, 17, 18, 19, 20, 21, 22, 23, 24, 25, 26, 27, 28)
  8. SECONDARY DIGITAL MENUBOARD. THE ENDS OF MENU BOARDS SHALL BE 18"-24" FROM THE FACE OF CURB. ANGLE RANGE SHALL BE MIN 25° FOR MAXIMUM VISIBILITY TO DRIVER. THE CENTER OF THE MENU BOARD FOUNDATION IS TO BE 5'-3" (5'-0" MIN AND 6'-0" MAX) FROM THE CENTER OF THE COO FOUNDATION. (1, 2, 3, 4, 5, 6, 7, 8, 9, 10, 11, 12, 13, 14, 15, 16, 17, 18, 19, 20, 21, 22, 23, 24, 25, 26, 27, 28)
  9. APPROX DRIVE PATH DISTANCE FROM NEW PRIMARY COO TO PAY WINDOW IS 60'
  10. DEMO. EX. COO AND MENU BOARD
  11. EX. PAY/PICKUP WINDOWS

**SCHEDULE #**

12. OUTDOOR FENCED PLAY AREA
13. APPROXIMATE EX. PROPERTY LINE
14. REPLACE EX. TRASH ENCLOSURE WITH 16'X16' TRASH ENCLOSURE AND INSTALL ROOF. SEE STRUCTURAL DRAWINGS.
15. EX. CONDITION DISTANCE FROM PAY WINDOW TO PICKUP WINDOW IS 43'
16. "THANK YOU" STRIPE IS TO BE 40'-0" FROM THE CENTER LINE OF THE PICKUP WINDOW (1, 2, 3, 4, 5, 6, 7, 8, 9, 10, 11, 12, 13, 14, 15, 16, 17, 18, 19, 20, 21, 22, 23, 24, 25, 26, 27, 28)
17. WIDEN CONCRETE PAD TO 14' x 15'
18. REPLACE EX. GATEWAY SIGN WITH NEW GATEWAY SIGN PER DETAILS (2, 3, 4, 5, 6, 7, 8, 9, 10, 11, 12, 13, 14, 15, 16, 17, 18, 19, 20, 21, 22, 23, 24, 25, 26, 27, 28)
19. INSTALL NEW COO PER DETAILS (1, 2, 3, 4, 5, 6, 7, 8, 9, 10, 11, 12, 13, 14, 15, 16, 17, 18, 19, 20, 21, 22, 23, 24, 25, 26, 27, 28)
20. INSTALL SECONDARY MENU BOARD 18" FROM FACE OF CURB (2, 3, 4, 5, 6, 7, 8, 9, 10, 11, 12, 13, 14, 15, 16, 17, 18, 19, 20, 21, 22, 23, 24, 25, 26, 27, 28)
21. RESTRIPE TYP. CROSSWALK. VERIFY SLOPE MEETS ADA SLOPE REQUIREMENT OF 1:20
22. INSTALL 6" THICK REINFORCED CONCRETE PER GENERAL NOTE E
23. NEW PULL FORWARD PARKING AND SIGNAGE
24. INSTALL 6" CONCRETE VERTICAL CURB PER DETAIL. MATCH EX. CURB. (1, 2, 3, 4, 5, 6, 7, 8, 9, 10, 11, 12, 13, 14, 15, 16, 17, 18, 19, 20, 21, 22, 23, 24, 25, 26, 27, 28)
25. PROTECT IN PLACE EX. UTILITY
26. RELOCATE EX. UTILITY TO LOCATION TBD ON SITE.
27. STENCIL "NO DUMPING" DRAINS TO BAY"
28. VERIFY EX. CURB RAMP MEETS ADA REQUIREMENTS. MAXIMUM 1:12 SLOPE.

**LEGEND**

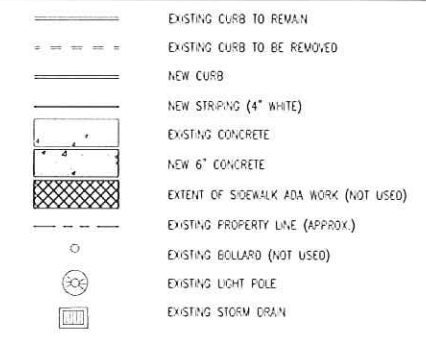

PARKING	
EX. BLDG	3,290 SQ FT
EX SPACES	24
PROPOSED SPACES	24
EX ADA	2 (1 VAN)
PROPOSED ADA	2 (1 VAN)
NET SPACES	0
REQ. PARKING @ 1 SPACE/200 SQ FT	17

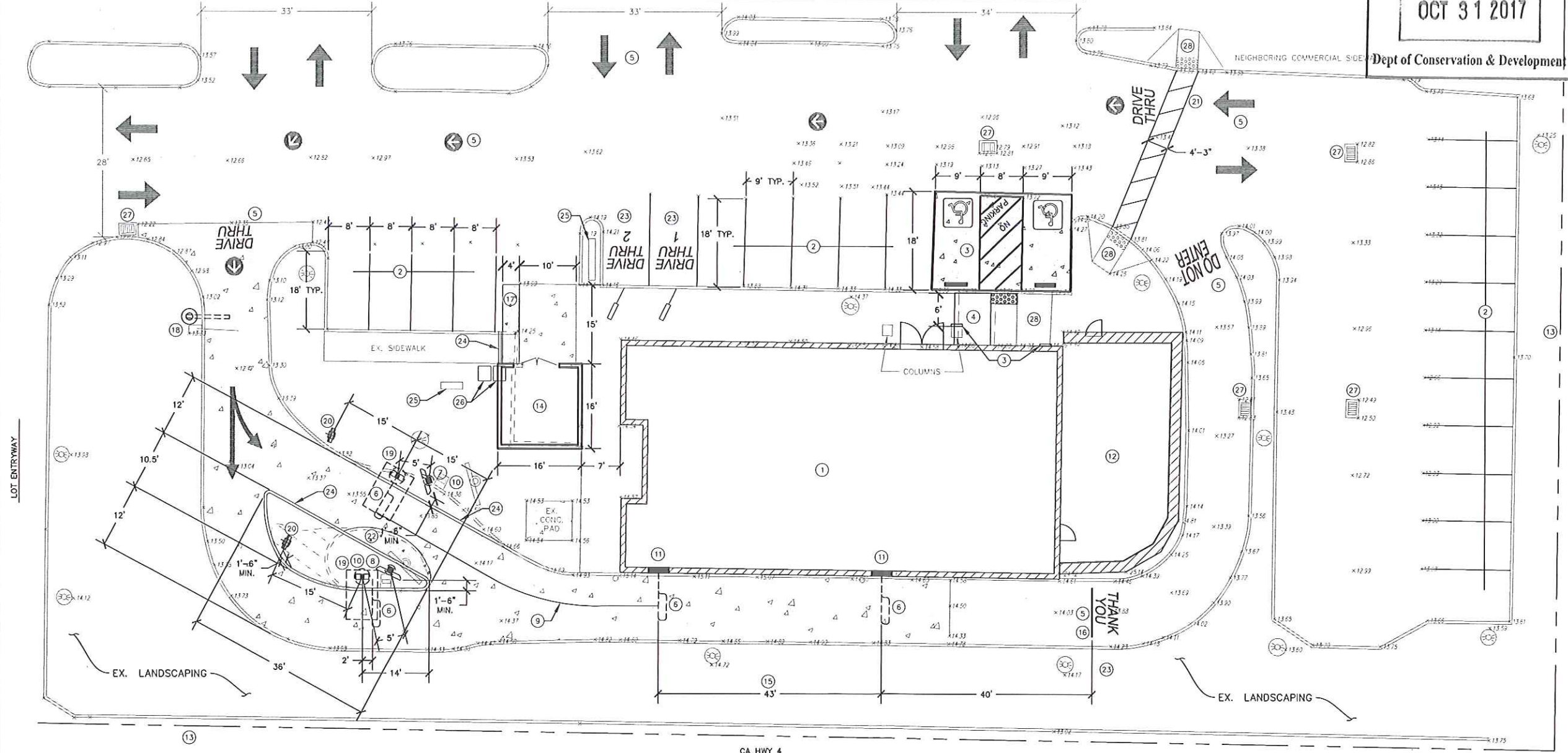

1917-2027

RECEIVED  
CONTRA COSTA COUNTY  
OCT 31 2017  
Dept of Conservation & Development

<p>PROFESSIONAL ENGINEER MILAN B. BERMAN No. 52920 State of California EXPIRES 06/30/18</p>	<p>DATE: 10/30/17</p>
<p>PREPARED BY: URS Corporation architects - engineers - planners 300 California St, Suite 600 San Francisco, CA 94104 973.883.8590 fax 973.883.8501 http://www.urscorp.com</p>	
<p>PREPARED FOR: M. McDonald's USA, LLC These drawings and specifications are the confidential and proprietary property of McDonald's USA, LLC and shall not be copied or reproduced without written authorization. The contract documents were prepared not suitable for use on a different site or at a later time. Use of the services of property licensed architects and engineers in preparation of the contract documents for reuse on another project is not authorized.</p>	
<p>DRWN BY: TI STD ISSUE DATE: REVIEWED BY: AECOM TEAM DATE ISSUED:</p>	<p>SHEET NO. 26085 SITE # 004-3772 DESCRIPTION: SITE PLAN 1 SITE ADDRESS: 1488 CH-1, DISCOVERY BAY, CA 94023 SITE ID: 004-3772</p>
<p>SP.1 CML SITE PLAN 1</p>	

AECOM PROJECT No. 60547138 Task No. 004-3772





Oct 30, 2017 -- 2:31pm  
 L:\Projects\McDonalds\60547138\_Civil\Sites\900-CAD-GIS\McD's\8-#26085 Discovery Bay SD Details Rev1.dwg

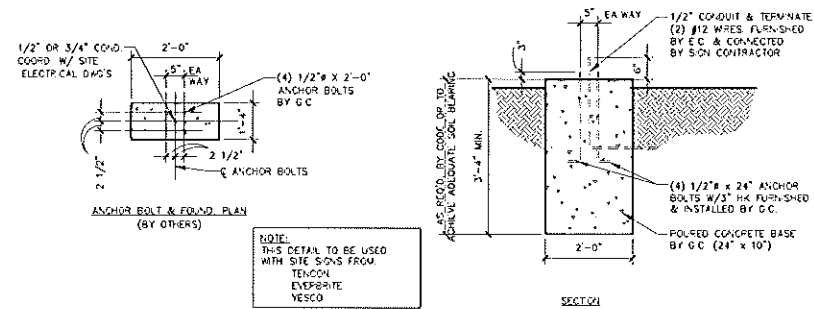

1 DIRECTIONAL SIGN FTG. (NOT USED)  
SD2 1/4"=1'-0"

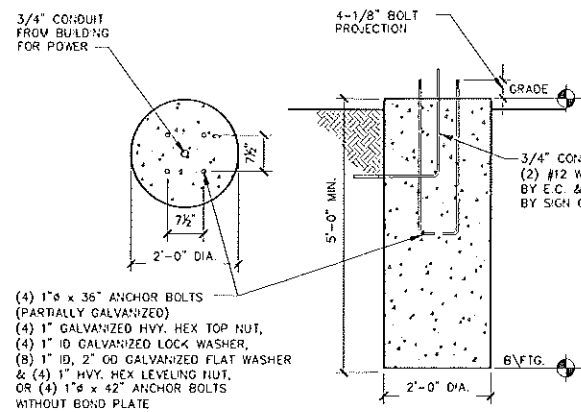

2 GATEWAY SIGN FTG. (NOT USED)  
SD2 1/4"=1'-0"

- NOTES:**
- G.C. TO COORDINATE THE RESPONSIBILITIES OF THE ELECTRICAL CONTRACTOR AND THE SIGN SUPPLIER.
  - GENERAL CONTRACTOR TO INSTALL PRE-FORMED, PRE-WIRED VEHICLE DETECTOR LOOP.
  - #12 GREEN GROUNDING CONDUCTOR MUST BE RUN WITH CIRCUIT CONDUCTORS FROM GROUND BUS IN PANEL UP TO ALL MENU BOARDS AND REFERENCE BOARDS.
  - ALL UNDERGROUND CONDUIT FOR AUDIO TO BE P.V.C. NO METAL ALLOWED.
  - DIRECTIONAL SIGN FOOTING DETAIL TO BE USED FOR ALL ENTER/EXIT/AELGIVE SIGNS AND DRIVE THRU DIRECTIONAL SIGNAGE. COORDINATE WITH THE SITE PLANS AND MCDONALD'S PROJECT MANAGER FOR THE EXACT LOCATION, ORIENTATION AND NUMBER OF SIGNS TO BE INSTALLED AT THIS SITE. ALL WORK TO BE COORDINATED WITH THE OTHER TRADES.
  - ALL GALVANIZED ANCHOR BOLTS TO BE SUPPLIED BY THE CONTRACTOR.
  - MAINTAIN 2 1/2" MIN. CONCRETE COVER OF ALL CONDUIT, REBAR, ETC.
  - SLOPED 1:48 TOP FROM CENTER TO EDGES & USE NON-SHRINK GROUT UNDER BASE.

3 GENERAL NOTES  
SD2

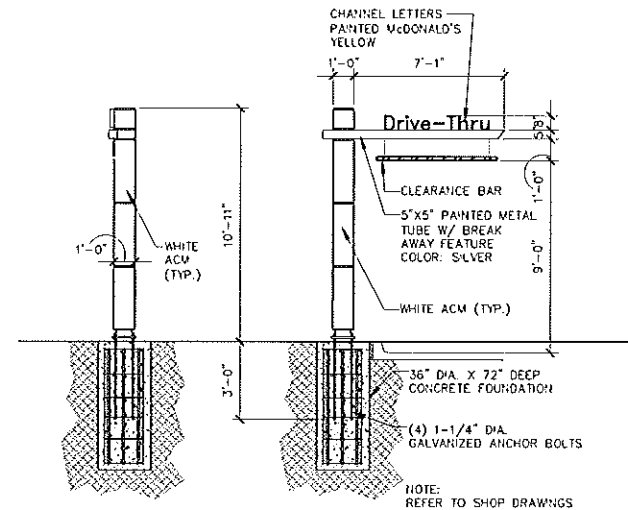

4 GATEWAY SIGN  
SD2 1/4"=1'-0"

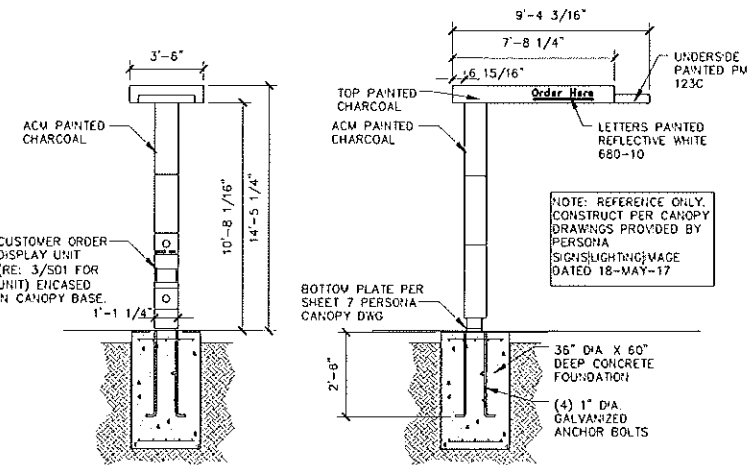

5 ORDER HERE CANOPY  
SD2 1/4"=1'-0"

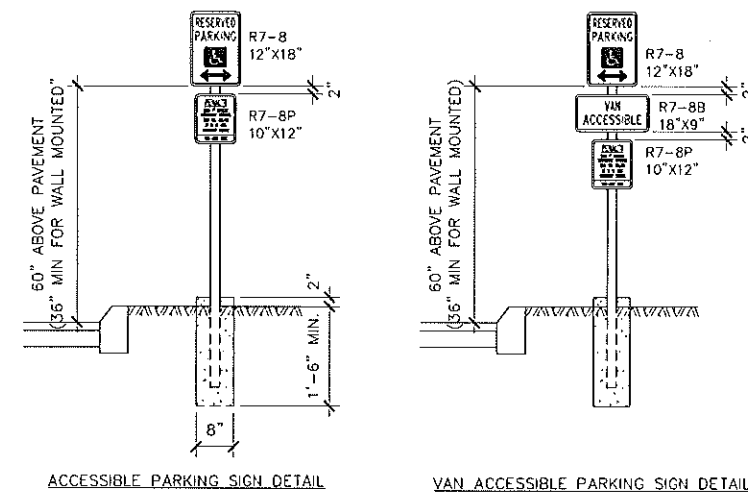

8 ACCESSIBLE SIGN DESIGNATIONS  
SD2 1/2"=1'-0"

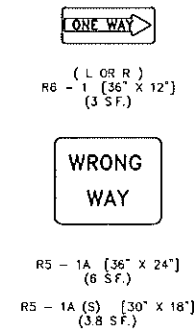

6 ONE WAY SIGNAGE (NOT USED)  
SD2 NOT TO SCALE

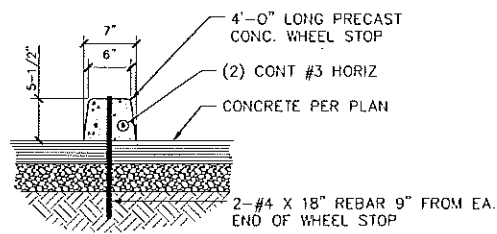

7 WHEEL STOP  
SD2 NOT TO SCALE

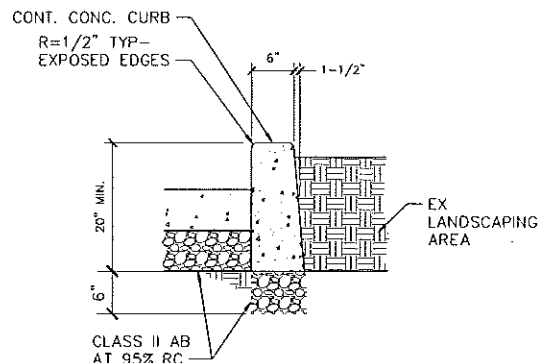

9 VERTICAL CURB  
SD2 NOT TO SCALE

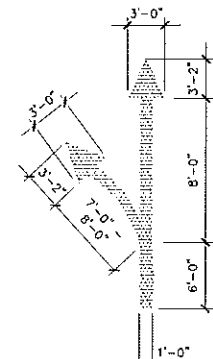

10 DOUBLE ARROW  
SD2 NOT TO SCALE

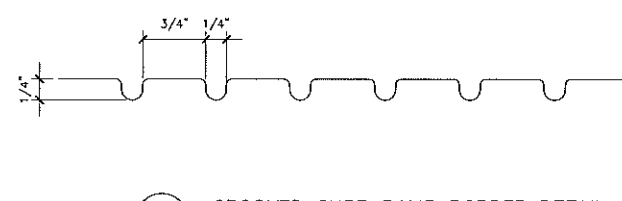

11 GROOVED CURB RAMP BORDER DETAIL  
SD2 NOT TO SCALE

		DATE: 10/30/17
PREPARED BY: <b>URS Corporation</b> architects - engineers - planners 300 California St, Suite 600 San Francisco, CA 94104 973.883.8590 fax 973.883.8501 <a href="http://www.urscorp.com">http://www.urscorp.com</a>	PROJECT NO: <b>McDonald's USA, LLC</b> 60547138	SHEET NO: <b>SD.2</b> CIVIL SITE DETAILS
DRAWN BY: DATE ISSUED: CHECKED BY: DATE CHECKED:	TITLE: Site # 004-3772	DESCRIPTION: CIVIL SITE DETAILS 2
PROJECT ADDRESS: 14850 Highway 4, Discovery Bay, CA 94924	SHEET NO: <b>SD.2</b> CIVIL SITE DETAILS	REVISIONS: NO.   DATE   DESCRIPTION

Oct 30, 2017 - 2:36pm L:\Projects\McDonalds\60547138\_Civil\Sites\900-CAD-CIS\McD\B-#26085 Discovery Bay SD Details Rev1.dwg

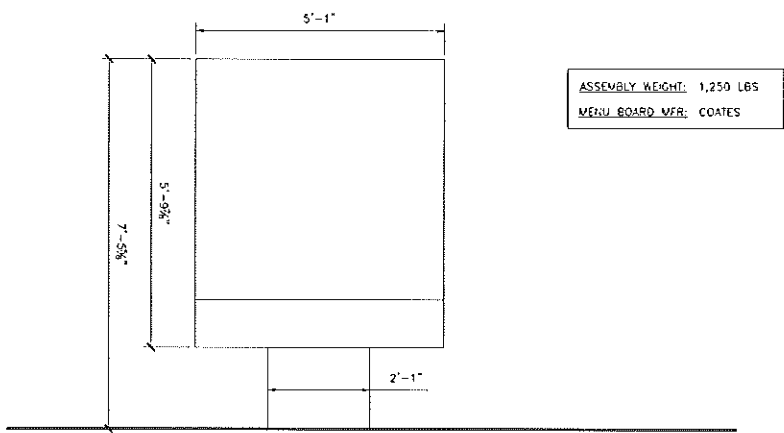

**ASSEMBLY WEIGHT: 1,250 LBS**  
**MENU BOARD MFR: COATES**

**GENERAL NOTES**  
-THE FOLLOWING CODES WERE USED IN DESIGN:  
-CBC 2016  
-ASCE 7-10  
-ACI 318-14  
-ASCE 350-10 & ASCE 341-10  
-AS 01.1  
-WIND SPEED: 130 MPH (ULTIMATE WIND SPEED)  
-EXPOSURE C  
-SEISMIC PARAMETERS: S<sub>s</sub> = 2.509; S<sub>ds</sub> = 2.007g  
S<sub>1</sub> = 1.013; S<sub>1</sub> = 1.148g  
-NOTE: DESIGN PARAMETERS LISTED ARE BASED ON WORST-CASE CRITERIA FOR WHICH THE DESIGN WAS PERFORMED AND MAY EXCEED SITE-SPECIFIC DESIGN PARAMETERS.  
-DESIGN LOADS DERIVED FROM THESE CODES  
-ANUL- 1,250 LB  
-SHEAR- 1,291 LB (STRENGTH-LEVEL)  
775 LB (ASD-LEVEL)  
-MOMENT- 5,933 LB-FT (STRENGTH-LEVEL)  
3,553 LB-FT (ASD-LEVEL)  
-ALL FOOTING EXCAVATIONS ARE TO BE CLEAR OF WATER AND FOREIGN MATTER BEFORE PLACING CONCRETE.  
-MINIMUM ALLOWABLE LATERAL SOIL BEARING PRESSURE OF 100 PSF/FT (x2)  
-TOP 12" OF SOIL NEGLECTED IN EMBEDMENT DEPTH CALCULATIONS (EMBEDMENT DEPTHS SHOWN ARE FROM GRADE)  
-ELECTRICAL CONTRACTOR TO PROVIDE INFORMATION ON CONDUIT AND ELECTRICAL REQUIREMENTS

**CONCRETE:**  
-ALL FOOTINGS SHALL BEAR ON FIRM UNDISTURBED RESIDUAL SOIL AND/OR ENGINEERED EARTH FILL COMPACTED TO 98% OF ITS MAXIMUM DRY DENSITY AS PER ASTM D 698-70 (STANDARD PROCTOR) UNLESS NOTED OTHERWISE  
-ALL PIERS TO EXTEND TO FROST DEPTH AS DETERMINED BY LOCAL JURISDICTION  
-TOP OF PIERS SHALL BE SLOPED SUCH THAT MOISTURE CANNOT ACCUMULATE  
-MINIMUM CONCRETE STRENGTH (FC=3,000 PSI) SHALL CONFORM WITH MCDONALD'S CAST-IN-PLACE CONCRETE SPECIFICATIONS SECTION 2.13-A  
-USE OF ADMIXTURES SHALL CONFORM TO MCDONALD'S CAST-IN-PLACE CONCRETE SPECIFICATION SECTION 2.8  
-AR ENTERTAINMENT SHALL CONFORM WITH MCDONALD'S CAST-IN-PLACE CONCRETE SPECIFICATIONS 2.6-A AND 2.13-A  
-WATER CONTENT RATIO SHALL CONFORM TO MCDONALD'S CAST-IN-PLACE CONCRETE SPECIFICATIONS SECTION 2.13-A  
-FOUNDATION CONCRETE TO BE TESTED PER MCDONALD'S CAST-IN-PLACE CONCRETE SPECIFICATIONS SECTION 3.14  
-PROVIDE A MINIMUM 3" OF CONCRETE COVER OVER ALL EMBEDDED STEEL  
-REINFORCEMENT PLACEMENT SHALL CONFORM TO MCDONALD'S CAST-IN-PLACE CONCRETE SPECIFICATIONS SECTIONS 3.2 & 3.5 PERFORMED BY GENERAL CONTRACTOR  
-ANCHOR RODS TO BE SET IN ACCORDANCE WITH AISC CODE OF STANDARD PRACTICE  
-DO NOT PLACE POLES ON CONCRETE UNTIL CONCRETE HAS CURED PER MCDONALD'S CAST-IN-PLACE CONCRETE SPECIFICATION SECTION 3.11-E

**STEEL:**  
-STEEL PIPE SECTION: ASTM A53 OR A252 TYPE E GRADE B (F<sub>y</sub>=35 KSI)  
-HSS ROUND SECTION: ASTM A500 GRADE B (F<sub>y</sub>=42 KSI)  
-HSS SQUARE/RECTANGULAR SECTIONS: ASTM A500 GRADE B (F<sub>y</sub>=42 KSI)  
-HEADED ANCHOR RODS: ASTM F1554 GR 55, S1 WHEN AN ACCEPTABLE ALTERNATIVE IS ASTM F1554 GR 55, S1  
-STEEL ANGLES, CHANNELS, STRUCTURAL SHAPES AND PLATES: ASTM A36  
-REINFORCEMENT: ASTM A615 GRADE 60 - BY GENERAL CONTRACTOR  
-NUTS: ASTM A563A, HEAVY HEX  
-WASHERS: ASTM F844 A36  
-USE ASTM A193 CLASS C HOT-DIPPED GALVANIZED BOLTS AND FASTENERS  
-ANCHOR RODS, NUTS, AND WASHERS SHALL BE SHIPPED AS AN ASSEMBLY FROM THE SIGN/LIGHTING MANUFACTURER  
-NO FIELD HEATING TO BEND STEEL SHALL BE ALLOWED WITHOUT ENGINEER'S APPROVAL  
-DO NOT CUT ANCHOR RODS AFTER INSTALLATION OF POLE  
-AFTER INSTALLATION, ALL EXPOSED STEEL SHALL BE PAINTED WITH AN ENAMEL PAINT TO INHIBIT CORROSION  
-ANY FIELD WELDING SHALL FIRST BE VERIFIED BY ENGINEER AND PERFORMED IN ACCORDANCE WITH AAS 01.1  
-REFER TO SIGN MANUFACTURER DRAWINGS AND INSTRUCTIONS FOR ADDITIONAL INFORMATION

**1 DIGITAL MENU BOARD**  
SD3 NOT TO SCALE

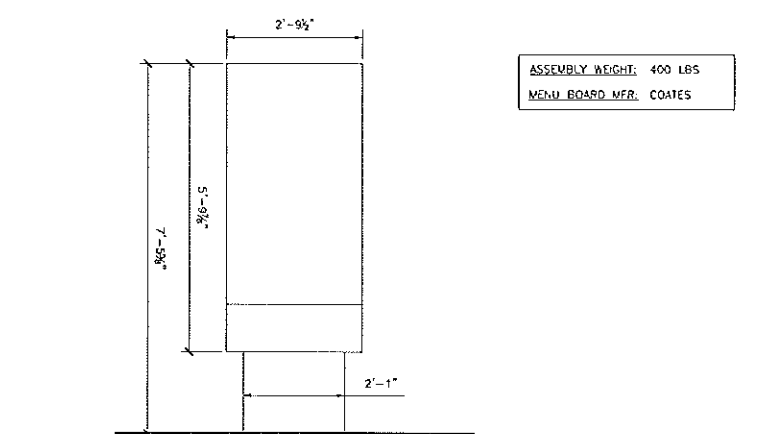

**ASSEMBLY WEIGHT: 400 LBS**  
**MENU BOARD MFR: COATES**

**GENERAL NOTES**  
-THE FOLLOWING CODES WERE USED IN DESIGN:  
-CBC 2016  
-ASCE 7-10  
-ACI 318-14  
-ASCE 350-10 & ASCE 341-10  
-AS 01.1  
-WIND SPEED: 130 MPH (ULTIMATE WIND SPEED)  
-EXPOSURE C  
-SEISMIC PARAMETERS: S<sub>s</sub> = 2.509; S<sub>ds</sub> = 2.007g  
S<sub>1</sub> = 1.013; S<sub>1</sub> = 1.148g  
-NOTE: DESIGN PARAMETERS LISTED ARE BASED ON WORST-CASE CRITERIA FOR WHICH THE DESIGN WAS PERFORMED AND MAY EXCEED SITE-SPECIFIC DESIGN PARAMETERS.  
-DESIGN LOADS DERIVED FROM THESE CODES  
-ANUL- 400 LB  
-SHEAR- 922 LB (STRENGTH-LEVEL)  
553 LB (ASD-LEVEL)  
-MOMENT- 3,780 LB-FT (STRENGTH-LEVEL)  
2,267 LB-FT (ASD-LEVEL)  
-ALL FOOTING EXCAVATIONS ARE TO BE CLEAR OF WATER AND FOREIGN MATTER BEFORE PLACING CONCRETE.  
-MINIMUM ALLOWABLE LATERAL SOIL BEARING PRESSURE OF 100 PSF/FT (x2)  
-TOP 12" OF SOIL NEGLECTED IN EMBEDMENT DEPTH CALCULATIONS (EMBEDMENT DEPTHS SHOWN ARE FROM GRADE)  
-ELECTRICAL CONTRACTOR TO PROVIDE INFORMATION ON CONDUIT AND ELECTRICAL REQUIREMENTS

**CONCRETE:**  
-ALL FOOTINGS SHALL BEAR ON FIRM UNDISTURBED RESIDUAL SOIL AND/OR ENGINEERED EARTH FILL COMPACTED TO 98% OF ITS MAXIMUM DRY DENSITY AS PER ASTM D 698-70 (STANDARD PROCTOR) UNLESS NOTED OTHERWISE  
-ALL PIERS TO EXTEND TO FROST DEPTH AS DETERMINED BY LOCAL JURISDICTION  
-TOP OF PIERS SHALL BE SLOPED SUCH THAT MOISTURE CANNOT ACCUMULATE  
-MINIMUM CONCRETE STRENGTH (FC=3,000 PSI) SHALL CONFORM WITH MCDONALD'S CAST-IN-PLACE CONCRETE SPECIFICATIONS SECTION 2.13-A  
-USE OF ADMIXTURES SHALL CONFORM TO MCDONALD'S CAST-IN-PLACE CONCRETE SPECIFICATION SECTION 2.8  
-AR ENTERTAINMENT SHALL CONFORM WITH MCDONALD'S CAST-IN-PLACE CONCRETE SPECIFICATIONS 2.6-A AND 2.13-A  
-WATER CONTENT RATIO SHALL CONFORM TO MCDONALD'S CAST-IN-PLACE CONCRETE SPECIFICATIONS SECTION 2.13-A  
-FOUNDATION CONCRETE TO BE TESTED PER MCDONALD'S CAST-IN-PLACE CONCRETE SPECIFICATIONS SECTION 3.14  
-PROVIDE A MINIMUM 3" OF CONCRETE COVER OVER ALL EMBEDDED STEEL  
-REINFORCEMENT PLACEMENT SHALL CONFORM TO MCDONALD'S CAST-IN-PLACE CONCRETE SPECIFICATIONS SECTIONS 3.2 & 3.5 PERFORMED BY GENERAL CONTRACTOR  
-ANCHOR RODS TO BE SET IN ACCORDANCE WITH AISC CODE OF STANDARD PRACTICE  
-DO NOT PLACE POLES ON CONCRETE UNTIL CONCRETE HAS CURED PER MCDONALD'S CAST-IN-PLACE CONCRETE SPECIFICATION SECTION 3.11-E

**STEEL:**  
-STEEL PIPE SECTION: ASTM A53 OR A252 TYPE E GRADE B (F<sub>y</sub>=35 KSI)  
-HSS ROUND SECTION: ASTM A500 GRADE B (F<sub>y</sub>=42 KSI)  
-HSS SQUARE/RECTANGULAR SECTIONS: ASTM A500 GRADE B (F<sub>y</sub>=42 KSI)  
-HEADED ANCHOR RODS: ASTM F1554 GR 55, S1 WHEN AN ACCEPTABLE ALTERNATIVE IS ASTM F1554 GR 55, S1  
-STEEL ANGLES, CHANNELS, STRUCTURAL SHAPES AND PLATES: ASTM A36  
-REINFORCEMENT: ASTM A615 GRADE 60 - BY GENERAL CONTRACTOR  
-NUTS: ASTM A563A, HEAVY HEX  
-WASHERS: ASTM F844 A36  
-USE ASTM A193 CLASS C HOT-DIPPED GALVANIZED BOLTS AND FASTENERS  
-ANCHOR RODS, NUTS, AND WASHERS SHALL BE SHIPPED AS AN ASSEMBLY FROM THE SIGN/LIGHTING MANUFACTURER  
-NO FIELD HEATING TO BEND STEEL SHALL BE ALLOWED WITHOUT ENGINEER'S APPROVAL  
-DO NOT CUT ANCHOR RODS AFTER INSTALLATION OF POLE  
-AFTER INSTALLATION, ALL EXPOSED STEEL SHALL BE PAINTED WITH AN ENAMEL PAINT TO INHIBIT CORROSION  
-ANY FIELD WELDING SHALL FIRST BE VERIFIED BY ENGINEER AND PERFORMED IN ACCORDANCE WITH AAS 01.1  
-REFER TO SIGN MANUFACTURER DRAWINGS AND INSTRUCTIONS FOR ADDITIONAL INFORMATION

**2 DIGITAL PRE-BROWSE BOARD**  
SD3 NOT TO SCALE

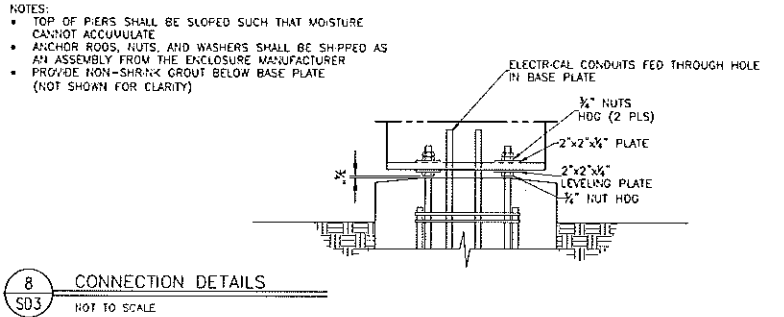
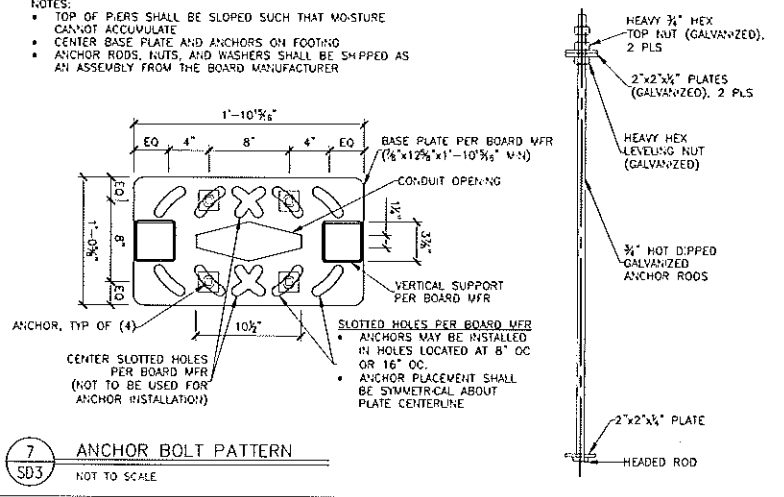
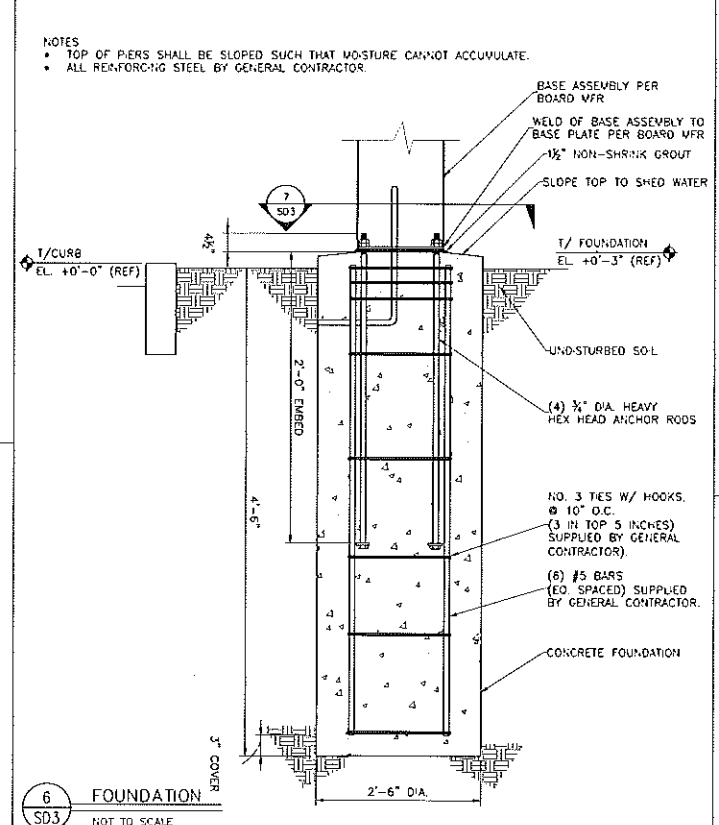
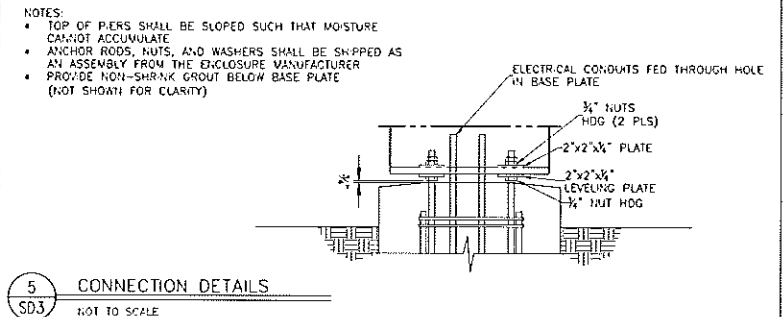
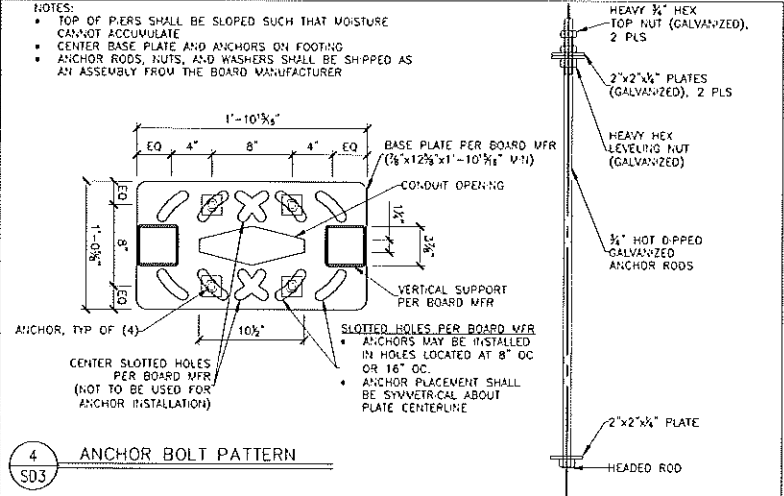
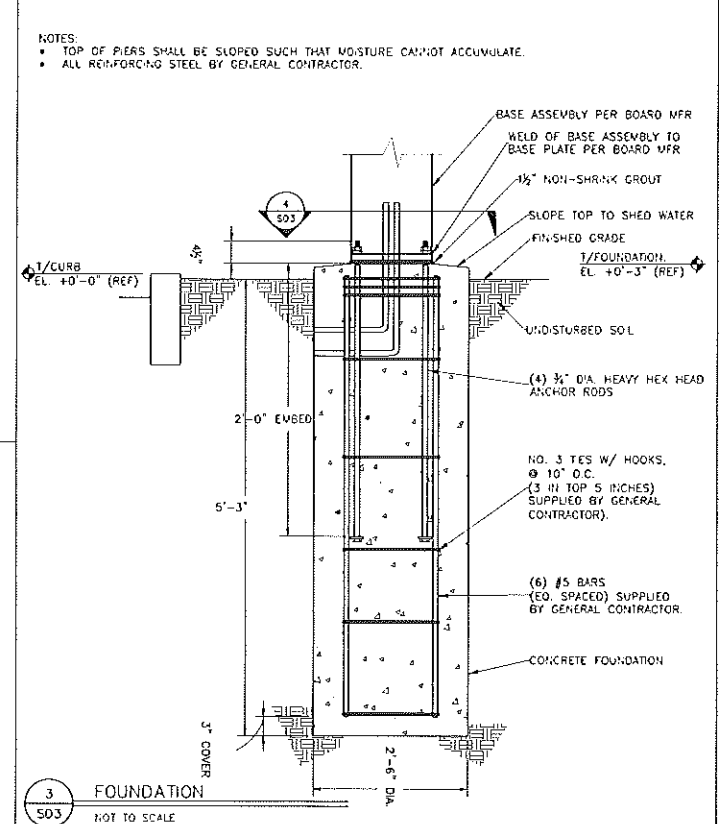

NO.	REV.	DATE	DESCRIPTION

DATE: 10/30/17

**McDonald's USA, LLC**  
Architects - engineers - planners  
300 California St., Suite 600  
San Francisco, CA 94104  
973.883.8590 fax: 973.883.8501  
http://www.usacorp.com

**McDonald's USA, LLC**  
CIVIL SITE DETAILS 3

SHEET NO. **SD.3**  
CIVIL SITE DETAILS



**KEY NOTES**

- BW** BRAND WALL
- C** ALUMINUM CANOPY SYSTEM ABOVE
- SF** EXISTING STOREFRONT/ GLAZING TO REMAIN
- T** NEW TRELLIS SYSTEM ABOVE
- T2** ALUMINUM TRELLIS TE-BACK SYSTEM

**SYMBOL LEGEND**

- EXISTING PARTITION/ WALL TO REMAIN
- NEW WALL/ PARTITION
- AREA NOT IN SCOPE

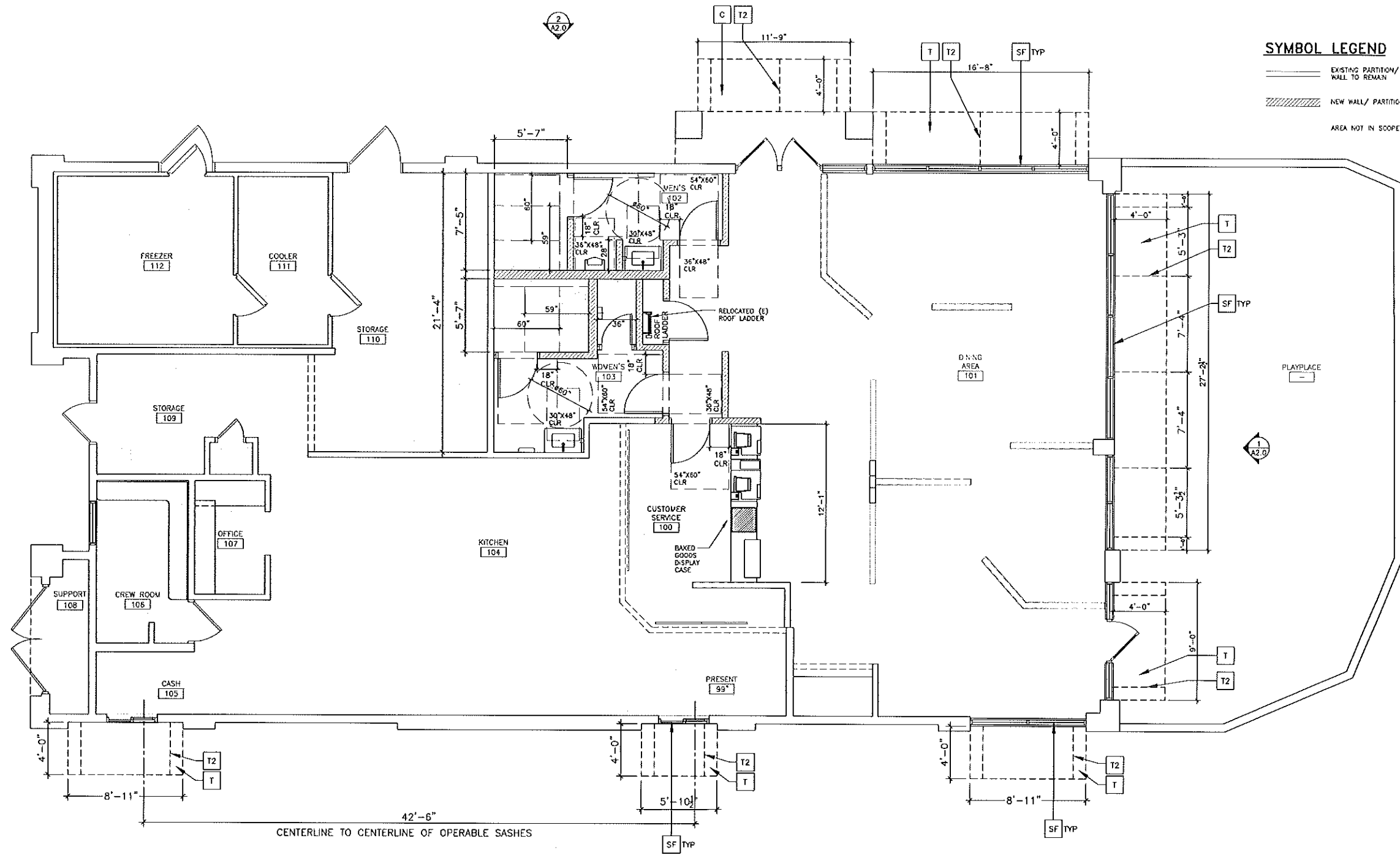

**1 PROPOSED FLOOR PLAN**  
A1.0 SCALE: 1/4" = 1'-0"

SHEET NO.	004-3772.00.0	TITLE	2017 MRP CORE 16 2.0	OWNER BY	STD. ISSUE DATE	PREPARED FOR:	M. McDonald's USA, LLC	PREPARED BY:	URS Corporation	DATE ISSUED	10.11.2017	DISCOVERY BAY, CA 94514
	DESCRIPTION		COMMERCIAL INTERIOR AND EXTERIOR RENOVATION		REVIEWED BY				ARCHITECT		URS Corporation - Planners	
SITE ADDRESS			004-3772	14806 HWY 4			DATE: 10/27/2017			REV	DATE	DESCRIPTION
<p><b>McDonald's USA, LLC</b>  <small>The drawings and specifications are the confidential and proprietary property of McDonald's USA, LLC. The contract documents were prepared without written authorization. The contractor shall be held responsible for any errors or omissions in the drawings and specifications. No part of these drawings shall be used for any other project without the written consent of McDonald's USA, LLC.</small></p> <p><b>URS Corporation</b>  <small>architects - engineers - planners</small>      300 California Street, Suite 600      Francisco, CA 94104      415.795.8100  <a href="http://www.urscorp.com">http://www.urscorp.com</a></p>												

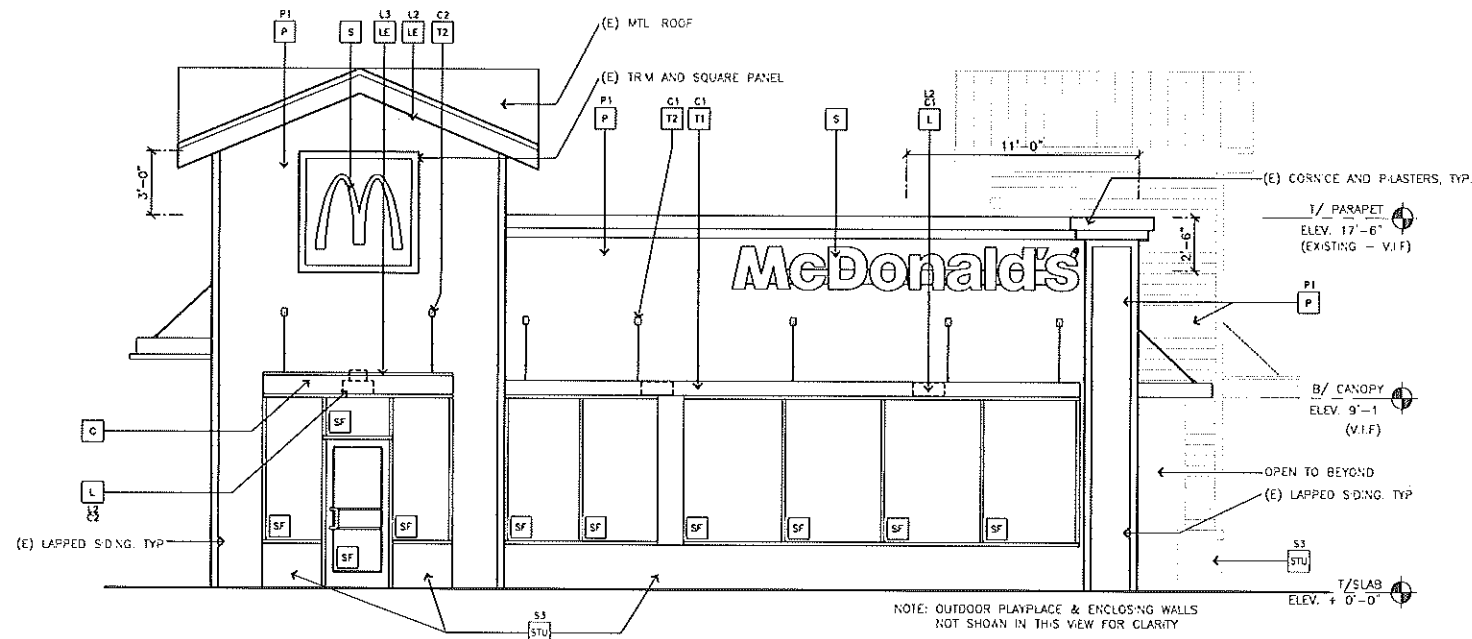

**1 PROPOSED FRONT ELEVATION**  
A2.0 SCALE: 1/4" = 1'-0"

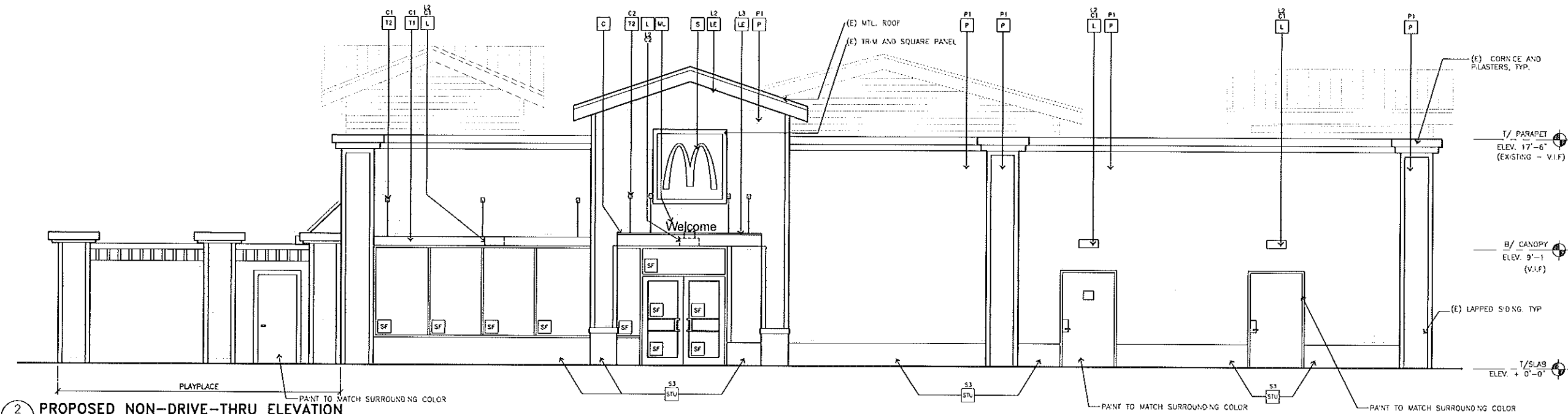

**2 PROPOSED NON-DRIVE-THRU ELEVATION**  
A2.0 SCALE: 1/4" = 1'-0"

**KEY NOTES:**

- BR** FACE BRICK
- EX** EXISTING
- EW** EXPANSION JOINT, SEE DETAIL
- GR** GUARD RAIL - SEE SITE PLAN FOR EXACT LOCATION AND LENGTH
- BR** BRAND WALL
- C** ALUMINUM CANOPY FASCIA SYSTEM COLOR: WHITE
- CD** COMPOSITE DECKING PRIVACY SCREEN PAINTED TO MATCH BUILDING
- CM** CORRUGATED METAL PANEL COLOR 1: 'CITYSCAPE' BY METAL-ERA COLOR 2: 'CHARCOAL GRAY' BY METAL-ERA
- D** HOLLOW METAL DOOR - PAINT TO MATCH COLOR OF SURROUNDING MATERIAL
- DS** DOWNSPOUT - PAINT TO MATCH
- EV** EXPANSION JOINT, SEE DETAIL
- GR** GUARD RAIL - SEE SITE PLAN FOR EXACT LOCATION AND LENGTH
- L** LIGHT FIXTURE - SEE ELECTRICAL
- LE** ACCENT LIGHTING - SEE ELECTRICAL
- MF** METAL FASCIA - COLOR TO MATCH CORRUGATED METAL PANEL
- P** PAINT FINISH
- PB** PIPE BOLLARD - EXISTING - PAINTED YELLOW
- PT** (RWHC) CON. COLLECTOR UNIT #API D12000 STD CALL 1-888-743-7435 TO ORDER
- RL** ROOF LADDER (EXISTING); PAINT TO MATCH ADJACENT SURROUNDING FACADE
- RO** ROOF DRAIN LEADER PAINT TO MATCH SURROUNDING MATERIAL
- S** MCDONALD'S SIGNAGE BY OTHERS - UNDER SEPARATE PERMIT
- SF** EXISTING STOREFRONT AND GLAZING TO REMAIN
- NT** REPLACE (E) TILE WITH NEW TILE
- SG** SPANDREL GLAZING TO REMAIN
- STU** STUCCO
- T1** ALUMINUM TRELLIS SYSTEM
- T2** ALUMINUM TRELLIS TIE-BACK SYSTEM
- T3** ALUMINUM TRELLIS 2" x 8" WALL FASCIA SYSTEM COLOR: CITYSCAPE
- W1** NEW EXTERIOR WINDOW ASSEMBLY - TEMPERED GLASS - SEE ASSEMBLY NOTES
- W2** DRIVE-THRU WINDOW BY READY ACCESS 600 SERIES, 36" SERVICE HEIGHT WITH TRANSOM - MANUAL OPEN, ELECTRONIC RELEASE

- C1** CITYSCAPE
- C2** WHITE
- C3** CHARCOAL
- C4** GOLD
- L1** NOT USED
- L2** DOWN ONLY SCIENCE
- L3** RECESSED DOWN FIXTURE
- L4** FLOOD LIGHT
- P1** PAINTED COLOR BASE BUILDING
- P2** PAINTED COLOR BRAND WALL
- P3** PAINTED COLOR BRAND WALL
- S1** TYPE (COLOR-SEE COLOR LEGEND)
- S2** NOT USED
- S3** PAINTED COLOR BRAND WALL/DT SURROUND
- T1** ALUMINUM TRELLIS SYSTEM
- XX** COLOR:
- T2** ALUMINUM TRELLIS TIE-BACK SYSTEM
- XX** COLOR:
- T3** ALUMINUM TRELLIS 2" x 8" WALL FASCIA SYSTEM
- XX** COLOR:
- W1** NEW EXTERIOR WINDOW ASSEMBLY - TEMPERED GLASS - SEE ASSEMBLY NOTES
- W2** DRIVE-THRU WINDOW BY READY ACCESS 600 SERIES, 36" SERVICE HEIGHT WITH TRANSOM - MANUAL OPEN, ELECTRONIC RELEASE
- XX** SLIDE DIRECTION: RL = RIGHT TO LEFT, LR = LEFT TO RIGHT

**COLOR LEGEND** (ALL COLORS ARE PER BENJAMIN MOORE PAINTS, U.S.A.)

MODERN SCHEME	BRAND WALLS	IRON MOUNTAIN BW# 2134-30
	BASE BUILDING	CHELSEA GRAY BW# HC-168
	DT SURROUND	IRON MOUNTAIN BW# 2134-30

**NOTE:**  
ALL GLAZING, DOORS, AND WINDOWS ARE EXISTING AND SHALL REMAIN, UNLESS NOTED OTHERWISE.

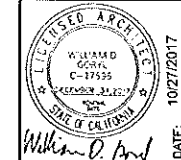

WILLIAM D. GRAY  
ARCHITECT  
300 CALIFORNIA STREET, SUITE 600  
SAN FRANCISCO, CA 94104  
415.795.8100  
http://www.williamgray.com

PREPARED FOR: **McDonald's USA, LLC**  
PREPARED BY: **URS Corporation**  
dba URS Corporation - planners  
architects - engineers - planners  
300 California Street, Suite 600  
San Francisco, CA 94104  
415.795.8100  
http://www.urscorp.com

DATE: 10/27/2017

TITLE	2017 MRP CORE 16 2.0
DESCRIPTION	COMMERCIAL INTERIOR AND EXTERIOR RENOVATION
SHEET NO.	A2.0
ELEVATION	

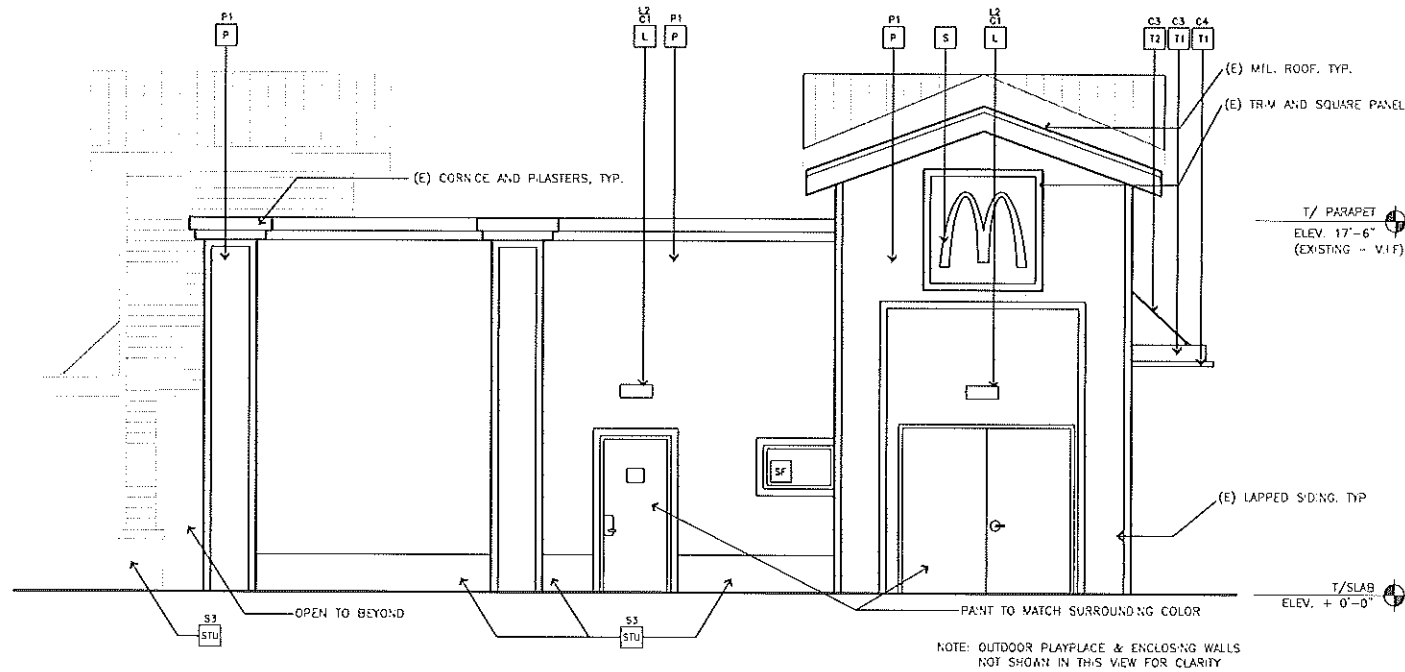

**1 PROPOSED REAR ELEVATION**  
A2.1 SCALE: 1/4" = 1'-0"

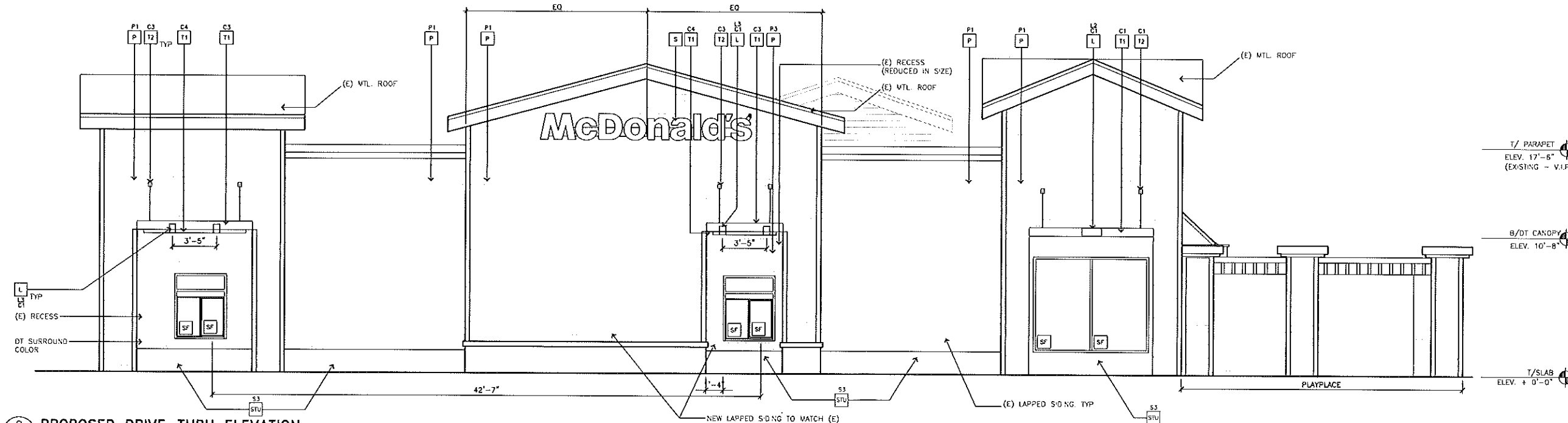

**2 PROPOSED DRIVE-THRU ELEVATION**  
A2.1 SCALE: 1/4" = 1'-0"

**KEY NOTES:**

- BR** FACE BRICK
- EX-TYPE**  
EX = EXISTING TO REMAIN  
MATCH = MATCH EXISTING BRICK
- EN** BRAND WALL
- C** ALUMINUM CANOPY FASCIA SYSTEM  
COLOR: WHITE
- EO** COMPOSITE DECKING PRIVACY SCREEN  
PAINTED TO MATCH BUILDING
- CM** CORRUGATED METAL PANEL  
COLOR 1: "CITYSCAPE" BY METAL-ERA  
COLOR 2: "CHARCOAL GRAY" BY METAL-ERA
- D** HOLLOW METAL DOOR - PAINT TO MATCH  
COLOR OF SURROUNDING MATERIAL
- DS** DOWNSPOUT - PAINT TO MATCH
- EJ** EXPANSION JOINT, SEE DETAIL
- GR** GUARD RAIL - SEE SITE PLAN  
FOR EXACT LOCATION AND LENGTH
- L** LIGHT FIXTURE - SEE ELECTRICAL  
XX-TYPE  
L1 = NOT USED  
L2 = DOWN ONLY SCENE  
L3 = RECESSED DOWN FIXTURE  
COLORS  
C1 = SILVER  
C2 = WHITE
- LE** ACCENT LIGHTING - SEE ELECTRICAL  
LED LIGHT  
XX-TYPE  
L1 = NOT USED  
L2 = DOWN ONLY FIXTURE  
L3 = INTEGRAL CANOPY FIXTURE  
L4 = FLOOD LIGHT
- ML** METAL LETTERING - BY OTHERS (COLOR:  
SILVER)
- MF** METAL FASCIA - COLOR TO MATCH CORRUGATED  
METAL PANEL  
T-TYPE  
1 = PRE-FAB ANCHOR-TITE FASCIA  
2 = PRE-FAB CUSTOM ARCADE FASCIA
- P** PAINT FINISH  
P1-TYPE: (COLOR-SEE COLOR LEGEND)  
P1 = PAINTED COLOR BASE BUILDING  
P3 = PAINTED COLOR BRAND WALL
- PB** PIPE BOLLARD - EXISTING - PAINTED YELLOW
- PT** (RWHC) CON COLLECTOR  
UNIT #PAPT D12000 STD  
CALL 1-888-743-7453 TO ORDER
- RL** ROOF LADDER (EXISTING); PAINT TO  
MATCH ADJACENT SURROUNDING FACADE
- RD** ROOF DRAIN LEADER  
PAINT TO MATCH SURROUNDING MATERIAL
- S** MCDONALD'S SIGNAGE BY OTHERS -  
UNDER SEPARATE PERMIT.
- SF** EXISTING STOREFRONT AND GLAZING TO  
REMAIN
- NT** REPLACE (E) TILE WITH NEW TILE
- SG** SPANDREL GLAZING TO REMAIN
- STU** STUCCO  
S1-TYPE: (COLOR-SEE COLOR LEGEND)  
S1 = PAINTED COLOR BASE BUILDING  
S2 = NOT USED  
S3 = PAINTED COLOR BRAND WALL/DT SURROUND
- T1** ALUMINUM TRELLIS SYSTEM  
XX - COLOR:  
C1 = CITYSCAPE  
C2 = WHITE  
C3 = CHARCOAL  
C4 = GOLD
- T2** ALUMINUM TRELLIS TIE-BACK SYSTEM  
XX - COLOR:  
C1 = CITYSCAPE  
C2 = WHITE  
C3 = CHARCOAL  
C4 = GOLD
- T3** ALUMINUM TRELLIS 2" x 8" WALL FASCIA SYSTEM  
COLOR: CITYSCAPE
- W1** NEW EXTERIOR WINDOW ASSEMBLY - TEMPERED GLASS  
-SEE ASSEMBLY NOTES
- W2** DRIVE-THRU WINDOW BY READY ACCESS 600 SERIES, 35" SERVICE  
HEIGHT WITH TRANSOM - MANUAL OPEN, ELECTRONIC RELEASE  
XX  
SLIDE DIRECTION RL = RIGHT TO LEFT  
LR = LEFT TO RIGHT

**COLOR LEGEND (ALL COLORS ARE PER BENJAMIN MOORE PAINTS, U.S.A.)**

MODERN SCHEME	BRAND WALLS	IRON MOUNTAIN BM# 2134-30
	BASE BUILDING	CHELSEA GRAY BW# HC-168
	DT SURROUND	IRON MOUNTAIN BM# 2134-30

**NOTE:**  
ALL GLAZING, DOORS, AND WINDOWS ARE EXISTING AND SHALL REMAIN, UNLESS NOTED OTHERWISE.



Prepared by:  
**URS Corporation**  
dba URS Corporation Americas  
architects - engineers - planners  
300 California Street, Suite 600  
San Francisco, CA 94104  
415.795.8100  
http://www.urscorp.com

Prepared for:  
**McDonald's USA, LLC**  
© 2012 McDonald's USA, LLC  
These drawings and specifications are the confidential and proprietary information of McDonald's USA, LLC. The contractor shall not use, copy, or reproduce these drawings or specifications for any other project without the written authorization of McDonald's USA, LLC. The contractor shall indemnify and hold McDonald's USA, LLC harmless from and against all claims, damages, and expenses, including reasonable attorneys' fees, arising from the use of these drawings or specifications for any other project without the written authorization of McDonald's USA, LLC. Reproduction of these drawings or specifications for any other project without the written authorization of McDonald's USA, LLC is prohibited.

DATE ISSUED 10.11.2017	DISCOVERY BAY, CA 94914
DATE REVISION 10.11.2017	
2017 MRP CORE 16 2.0	
DESCRIPTION COMMERCIAL INTERIOR AND EXTERIOR RENOVATION	
SHEET NO. A2.1 ELEVATION	

NOTE: THE PLAYPLACE IS NOT DEPICTED HERE FOR BETTER CLARITY.



Front Elevation

T/ PARAPET  
ELEV. 17'-6"  
(EXISTING - V.I.F.)

B/ CANOPY  
ELEV. 9'-1"  
(V.I.F.)

T/SLAB  
ELEV. 1'-0"

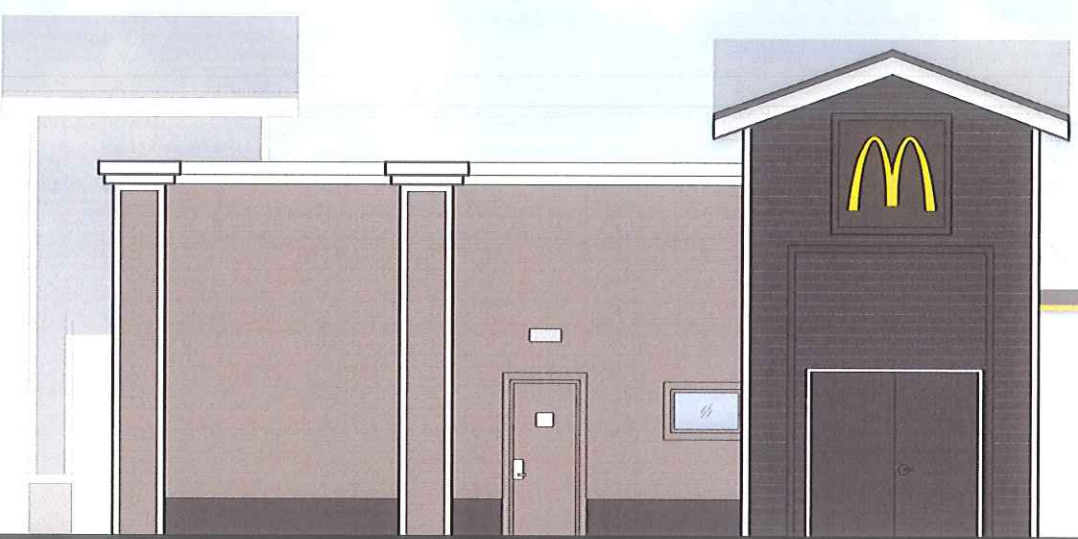

Rear Elevation

T/ PARAPET  
ELEV. 17'-6"  
(EXISTING - V.I.F.)

T/SLAB  
ELEV. 1'-0"



Non-Drive-Thru Side Elevation

T/ PARAPET  
ELEV. 17'-6"  
(EXISTING - V.I.F.)

B/DT CANOPY  
ELEV. 10'-8"

T/SLAB  
ELEV. 1'-0"



Drive-Thru Side Elevation

T/ PARAPET  
ELEV. 17'-6"  
(EXISTING - V.I.F.)

B/ CANOPY  
ELEV. 9'-1"  
(V.I.F.)

T/SLAB  
ELEV. 1'-0"

- SCHEME: MODERN**
- Materials Legend:**
- Base Color: Chelsea Gray BM-RC-168
  - Brand Walls/DT-Accent: Iron Mountain BM-2134-30
  - Aluminum Canopy (Metal)
  - Glazing (Windows + Storefront)
  - Aluminum Trellis
  - Metal (Coping)
  - Corrugated Metal

REVISIONS		
NO.	DATE	DESCRIPTION
-	-	-
-	-	-
-	-	-
-	-	-
-	-	-
-	-	-
-	-	-
-	-	-

SEAL

SEAL NOTE

PREPARED FOR  
**McDonald's USA LLC**

These drawings and specifications are the confidential and proprietary property of McDonald's USA, LLC and shall not be copied or reproduced without written authorization. The contract documents were prepared for use on this specific site in conjunction with its issue date and are not suitable for use on a different site or at a later time. Use of these drawings for reference or example on another project requires the services of properly licensed architects and engineers. Reproduction of the contract documents for reuse on another project is not authorized.

PROJECT DESCRIPTION  
**EXISTING CONDITIONS**

PROJECT LOCATION  
**McDonald's  
14896 HWY 4  
DISCOVERY BAY, CA  
94514**

SHEET TITLE  
**FLOOR PLAN**

SHEET MANAGEMENT  
PROJECT NO.: **004-3772**  
DATE ISSUED: 01-23-2017  
DRAWN BY: V.B.  
REVIEWED BY: T.C.

NATIONAL STORE #  
**26085**

SHEET NUMBER  
**A1.0**  
EX. FLOOR PLAN

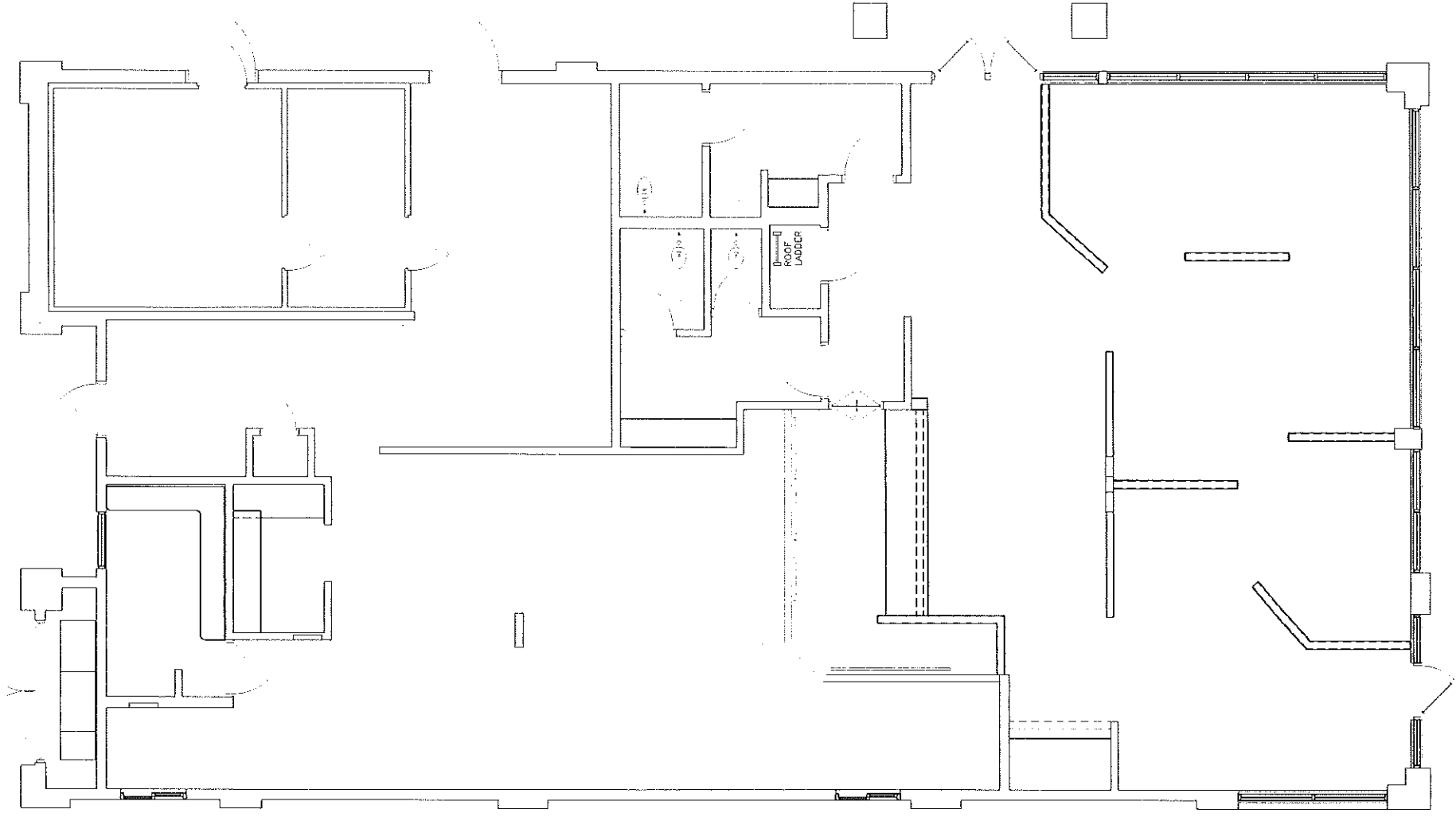

**1** EXISTING FLOOR PLAN  
A1.0 SCALE: 1/4" = 1'-0"  
TOTAL SQ. FT. = 3,290

**EXISTING PLAN**  
FOR REFERENCE USE ONLY



SAFETY - INTEGRITY - SUSTAINABILITY

REVISIONS		
NO	DATE	DESCRIPTION

SEAL

SEAL NOTE

PREPARED FOR  
**McDonald's USA LLC**  
 These drawings and specifications are the confidential and proprietary property of McDonald's USA, LLC and shall not be copied or reproduced without written authorization. The contract documents were prepared for use on this specific site in conjunction with its issue date and are not suitable for use on a different site or at a later time. Use of these drawings for reference or reuse on another project requires the services of properly licensed architects and engineers. Reproduction of the contract documents for reuse on another project is not authorized.

PROJECT DESCRIPTION  
**EXISTING CONDITIONS**

PROJECT LOCATION  
**McDonald's**  
 14896 HWY 4  
 DISCOVERY BAY, CA  
 94514

SHEET TITLE  
**EXTERIOR ELEVATIONS**

SHEET MANAGEMENT  
 PROJECT NO: **004-3772**  
 DATE ISSUED: 01-23-2017  
 DRAWN BY: UB  
 REVIEWED BY: TC  
 NATIONAL STORE #  
**26085**

SHEET NUMBER  
**A2.1**  
 EX. EXTERIOR ELEVATIONS

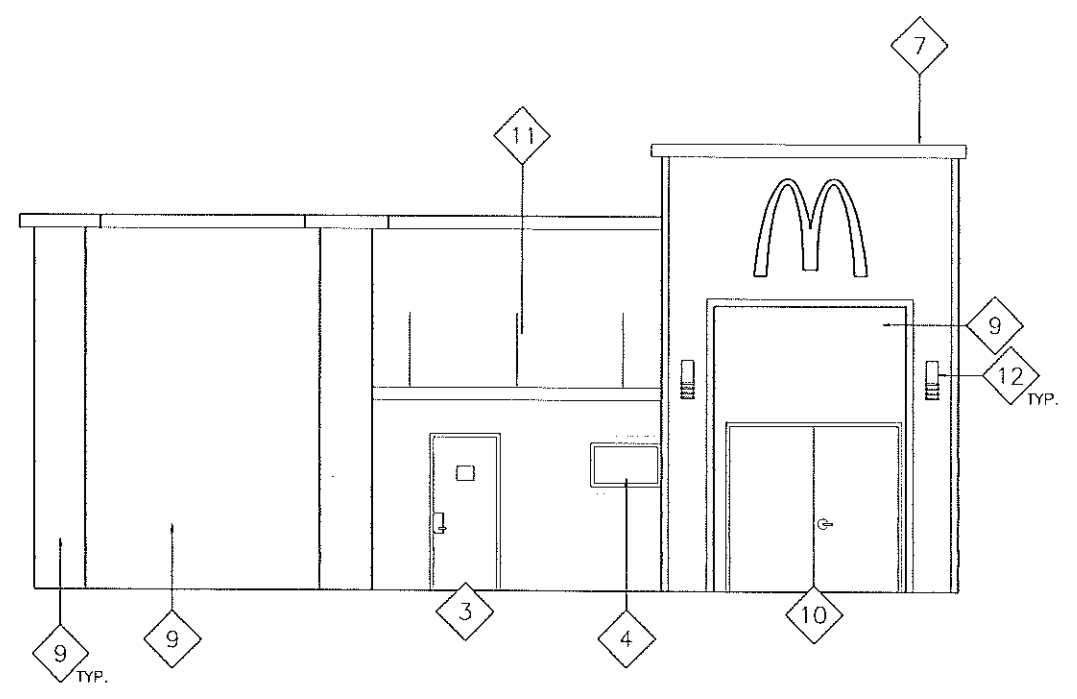

**1 EXISTING REAR ELEVATION**  
 A2.1 SCALE: 1/4" = 1'-0"

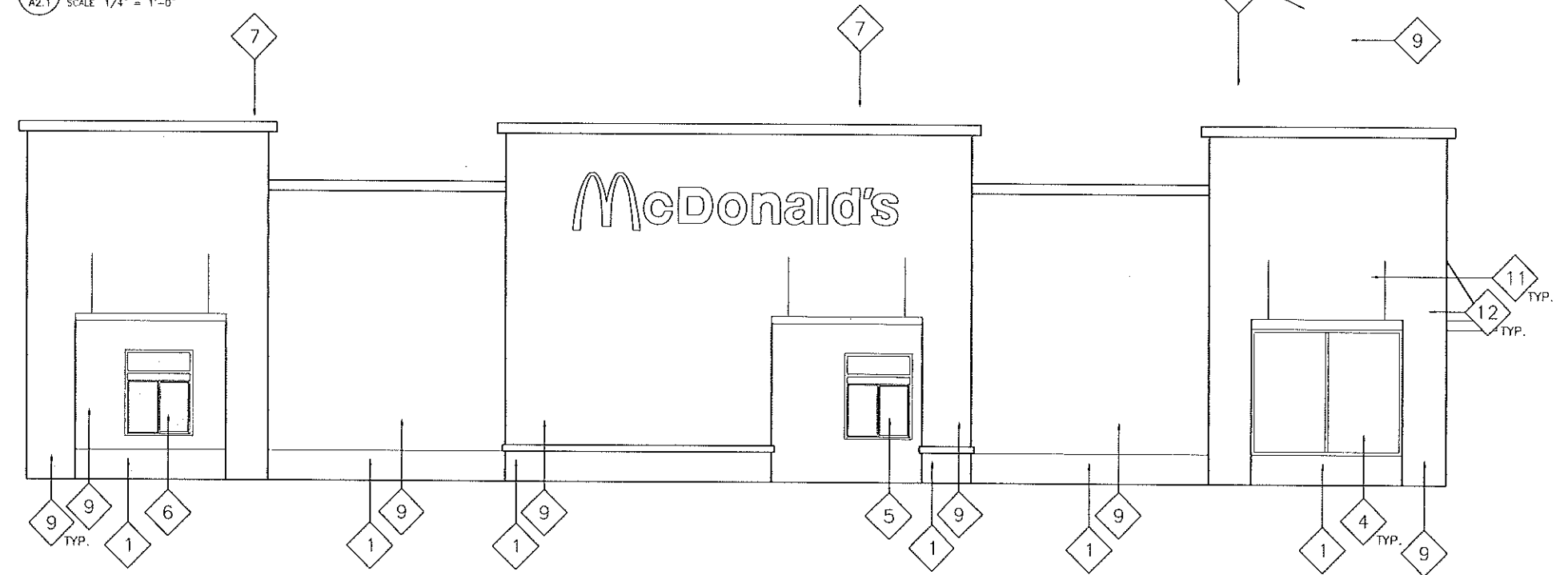

**2 EXISTING DRIVE-THRU ELEVATION**  
 A2.1 SCALE: 1/4" = 1'-0"

- |                  |                  |                  |                      |
|------------------|------------------|------------------|----------------------|
| 1 STUCCO         | 4 GLAZING        | 7 METAL ROOF     | 10 ELECTRICAL CLOSET |
| 2 CUSTOMER ENTRY | 5 SERVICE WINDOW | 8 FREEZER ACCESS | 11 METAL OVERHANG    |
| 3 EMPLOYEE ENTRY | 6 CASH WINDOW    | 9 LAP SIDING     | 12 EXTERIOR LIGHTING |

**EXISTING ELEVATIONS**  
 FOR REFERENCE USE ONLY



# Town of Discovery Bay

*"A Community Services District"*

## STAFF REPORT

Meeting Date

December 6, 2017

**Prepared By:** Gregory Harris, HERWIT Engineering  
**Submitted By:** Michael Davies, General Manager

MPD

### Agenda Title

Discussion and possible action regarding the approval of Notice of Completion for Plant No. 2 - Effluent Filtration Project (Master Plan Projects No. 5, 7, 10, 12).

### Recommended Action

Consider approval of the Notice of Completion and authorize the General Manager to release all retention for this project to Auburn Construction.

### Executive Summary

The Effluent Filtration project is now completed (see attached pictures) the only outstanding issue are some items currently being replaced under warranty form the manufacturers.

Current project retention is \$313,707.54 Staff recommends releasing 100% of this retention.

Bid cost for this project was **\$6,401,300.00**,

Final contract cost was **\$6,274,150.75**.

HERIWT Engineering design cost were \$428,377

HERWIT Engineering construction services costs to date are \$349,931

HERWIT Engineering record drawings costs will be approximately \$15,000

Other Miscellaneous Costs for Pilot, Klienfelder, Veolia, Geotech approximately \$184,750

Total Project Costs \$7,237,000

Original Project CIP Cost \$7,400,000

Project under budget approximately **\$163,000**

### Fiscal Impact:

**Amount Requested none**

**Sufficient Budgeted Funds Available?: Yes**

**Prog/Fund # 21-1155-73 Category: CIP Wastewater**

### Previous Relevant Board Actions for This Item

Approved the 2016/2017 CIP Approved Award of Construction.

### Attachments:

Notice of Completion

Filtration Equipment Pictures

AGENDA ITEM: G-5

RECORDING REQUESTED BY AND  
WHEN RECORDED RETURN TO:

TOWN OF DISCOVERY BAY COMMUNITY  
SERVICES DISTRICT  
1800 Willow Lake Road  
Discovery Bay, CA 94505-9376

**NOTICE OF COMPLETION**

NOTICE IS HEREBY GIVEN THAT:

1. The undersigned is the Owner who contracted for the work of improvement hereinafter described.
2. The full name of the undersigned is:  

TOWN OF DISCOVERY BAY COMMUNITY SERVICES DISTRICT, a Political Subdivision of  
the State of California.
3. The full address of the undersigned is:  

1800 Willow Lake Road  
Discovery Bay, CA 94505-9376
4. The nature of the title of the undersigned is that of a fee holder.
5. A work of improvement on the property hereinafter described was completed on 10/10/2017.
6. The name of the contractor for such work of improvement is Auburn Constructors, Inc.
7. The property on which said work of improvement was completed is in the unincorporated portion of the County of Contra Costa, State of California, and is described as follows:  

Wastewater Treatment Plant No. 2  
17501 Highway 4  
Discovery Bay, CA 94505
8. The work of improvement consists generally of:
  - A. Effluent Filtration Project.

MICHAEL R. DAVIES, GENERAL MANAGER  
FOR TOWN OF DISCOVERY BAY COMMUNITY SERVICES  
DISTRICT

---



**Figure 1 - New Filter System at the Town of Discovery Bay**



**Figure 2 - EcoWash ACP NEMA 4X Air Control Panels, 3 Per Side, Total of 6.**



**Figure 3 - Filter Control Panel and Air Compressors**



**Figure 4 - Air Compressors for Filter System**



Figure 5 - Filter Control Panel



Figure 6 - Filter Control Panel Controls Operation of the EcoWash Feature Which is Selectable From the Main Control Screen.



# EAST CONTRA COSTA FIRE PROTECTION DISTRICT

## Meeting Minutes Board of Directors Regular Meeting

**Monday November 06, 2017 6:30 P.M.**

***Meeting Location: Brentwood City Council Chambers,  
150 City Park Way, Brentwood***

<b>BOARD OF DIRECTORS</b>		
Joy Benson	Joel Bryant-President	Erick Stonebarger
Robert Kenny	Brian Oftedal -Vice President	Adam Langro
Cheryl Morgan	Joe Young	Susan Morgan

**6:30PM – Call to Order:** (6:37 P.M.)

**PLEDGE OF ALLEGIANCE:** (6:37 P.M.)

**ROLL CALL:** (6:37 P.M.)

Directors Present: Benson, Bryant, Kenny, Langro, Oftedal, C. Morgan, S. Morgan, Young  
Directors Absent: Stonebarger

**PUBLIC COMMENTS:** (6:38 P.M.)

There were three (3) Public Speakers – Gil Guerrero, Hal Bray, and Mark Whitlock

**Presentation:** (6:45 P.M.)

**P.1 Administration of Oath of Office for Interim Battalion Chief Craig Auzenne**

**CONSENT CALENDAR:** (6:50 P.M.)

**C.1 Approve Minutes from October 02, 2017 Board of Directors Meeting**

**C.2 Approve Purchase Card and District Corporate Account Policy**

**Motion by: Director Oftedal to approve consent items C.1 & C.2**

**Second by: Director Young**

**Vote Carried: 8:0:0**

**Ayes: Benson, Bryant, Kenny, Langro, C. Morgan, S. Morgan, Oftedal, Young**

**Noes:**

**Abstained:**

**Absent: Stonebarger**

Minutes November 06, 2017  
Page 1 of 4

**C.3 Board Meeting Schedule for Calendar Year 2018**

C-3 was pulled to discuss scheduled dates for 2018. The Board meeting schedule for 2018 was amended to read:

January 8, 2018 (second Monday due to New Year's Day holiday)  
February 5, 2018  
March 5, 2018  
April 9, 2018  
May 7, 2018  
June 4, 2018  
July 2, 2018  
August 6, 2018  
September 10, 2018 (second Monday due to Labor Day holiday)  
October 1, 2018  
November 5, 2018  
December 3, 2018

**Motion by: Director Oftedal to approve consent item C.3, as amended**

**Second by: Director C. Morgan**

**Vote Carried: 8:0:0**

**Ayes: Benson, Bryant, Kenny, Langro, C. Morgan, S. Morgan, Oftedal, Young**

**Noes:**

**Abstained:**

**Absent: Stonebarger**

**PUBLIC HEARING: (6:55P.M.)**

**PH.1. Hold Public Hearing on and Adopt Ordinance Adopting Modified 2016 California Fire Code**

There were no (0) Public Speakers

**Motion by: Director Young to adopt Ordinance Adopting Modified  
2016 California Fire Code**

**Second by: Director Kenny**

**Vote Carried: 7:0:1**

**Ayes: Benson, Bryant, Kenny, Langro, S. Morgan, Oftedal, Young**

**Noes:**

**Abstained: C. Morgan**

**Absent: Stonebarger**

**DISCUSSION ITEMS**

(7:02 P.M.)

**D.1 Discuss Cost Recovery Billing for Certain District Services**

Mike Rivera from Fire Recovery USA made a presentation.

There were no (0) Public Speakers.



Direction was given to staff to takes the administrative steps necessary to present a cost recovery program to the Board for approval.

(7:33 P.M.)

**D.2** Resolution calling all-mail ballot election on March 6, 2018 to reduce board to 5 members

There wa one (1) Public Speakers – Bill Merit

**Motion by: Director Young to adopt a resolution calling an all-mail ballot election to reduce the Board to 5 members**

**Second by: Director Benson**

**Vote Carried: 6:0:2**

**Ayes: Benson, Bryant, Kenny, Langro, Oftedal, Young**

**Noes: C. Morgan, S.Morgan**

**Abstained:**

**Absent: Stonebarger**

(8:13 P.M.)

**D.3** Announce ad hoc committee for strategic planning proposal evaluation

There was one (1) Public Speaker – Hal Bray

Director Young and Director Langro volunteered to serve on this ad hoc committee, with appointments to be made at the discrction of the Board President.

(8:24 P.M.)

**D.4** Announce ad hoc committee for legislative services

Director Benson, Director Oftedal and Director Susan Morgan volunteered to serve on this ad hoc committee, with appointments to be made at the discrction of the Board President.

(8:28 P.M.)

**D.6** Receive Operational Update for October 2017

Director Auzenne reported on the Operational Update for October 2017. Director Langro requested for the report include Response Time for the calls that are being covered by an outside agency when no District resources are available.

**INFORMATIONAL STAFF REPORTS: (8:47P.M.)**

1. Receive Update on the District's October Public Outreach & Education Activities

**DIRECTORS' COMMENTS: (8:47 P.M.)**

**INFORMATIONAL REPORTS AND REQUESTS FOR FUTURE AGENDA ITEMS FROM BOARD MEMBERS: (8:49 P.M.)**

None

**RECESS TO CLOSED SESSION ON THE FOLLOWING MATTERS: (8:49P.M.)**

1. Conference With Labor Negotiator Pursuant to Government Code Section 54957.6  
Agency Designated Representative: Glenn Berkheimer  
Employee Organization: International Association of Fire Fighters, Local 1230
2. Conference With Legal Counsel – Anticipated Litigation  
Initiation of litigation pursuant to Government Code Section 54956.9(d)(4): 1 potential case
3. Closed session: Public Employee Performance Evaluation Pursuant to Government Code Section 54957(b)(1)  
Title: Fire Chief

**REPORT ON CLOSED SESSION: (11:21 P.M.)**

No actions were reported out on Closed Session on Items 1, 2 & 3.

**ADJOURN TO THE REGULAR BOARD MEETING SCHEDULED: December 04, 2017:  
(11:21 P.M.)**