



TOWN OF DISCOVERY BAY
COMMUNITY SERVICES DISTRICT
AGENDA PACKET

For the Meeting of Wednesday
November 6, 2013

7:00 P.M. Regular Meeting

District Office
1800 Willow Lake Road



TOWN OF DISCOVERY BAY

A COMMUNITY SERVICES DISTRICT

President – Mark Simon • Vice-President – Kevin Graves • Director – Bill Pease • Director – Chris Steele • Director – Marianne Wiesen

**NOTICE OF THE REGULAR MEETING
OF THE BOARD OF DIRECTORS
OF THE TOWN OF DISCOVERY BAY
Wednesday November 6, 2013
REGULAR MEETING 7:00 P.M.
1800 Willow Lake Road, Discovery Bay, California
Website address: www.todb.ca.gov**

REGULAR MEETING 7:00 P.M.

A. ROLL CALL AND PLEDGE OF ALLEGIANCE

1. Call business meeting to order 7:00 p.m.
2. Pledge of Allegiance
3. Roll Call

B. PUBLIC COMMENTS (Individual Public Comments will be limited to a 3-minute time limit)

During Public Comments, the public may address the Board on any issue within the District's jurisdiction which is not on the agenda. The public may comment on any item on the Agenda at the time the item is before the Board for consideration. Any person wishing to speak must come up and speak from the podium. There will be no dialog between the Board and the commenter. Any clarifying questions from the Board must go through the Chair.

C. PRESENTATIONS

D. AREA AGENCIES REPORTS / PRESENTATION

1. Sheriff's Office Report
2. CHP Report
3. Fire District Report
4. East Contra Costa Fire Protection District Report
5. Supervisor Mary Piepho, District III Report

E. COMMITTEE/LIAISON REPORTS

1. Trans-Plan Report
2. County Planning Commission Report
3. Code Enforcement Report
4. Special Districts Report**

***These meetings are held Quarterly*

F. CONSENT CALENDAR

All matters listed under the CONSENT CALENDAR are considered by the District to be routine and will be enacted by one motion.

1. DRAFT minutes of previous annual Public Financing Authority meeting dated October 16, 2013
2. DRAFT minutes of previous regular meeting dated October 16, 2013
3. DRAFT minutes of previous joint meeting of the Board of Directors and Community Center Committee dated October 23, 2013
4. Approve Register of District Invoices

G. NEW BUSINESS AND ACTION ITEMS

1. Purchase video surveillance system for the Discovery Bay Community Center
2. Update on Investigation of low wastewater flows at the WWTPs

H. PRESIDENT REPORT AND DIRECTORS' COMMENTS

I. MANAGER'S REPORT

J. GENERAL MANAGER'S REPORT

K. DISTRICT LEGAL COUNSEL REPORT

L. COMMITTEE UPDATES – Discussion and Possible Action

1. Community Center Status Report (No written report)

M. CORRESPONDENCE – Discussion and Possible Action

1. R – Discovery Bay P-6 Zone Citizen Advisory Committee meeting minutes dated July 17, 2013
2. R – Byron Municipal Advisory Council meeting minutes dated August 15, 2013

N. PUBLIC RECORD REQUESTS RECEIVED

1. Public Record Request Received on 10-23-13 – Mr. Gutierrez, California Taxpayers Association

O. FUTURE AGENDA ITEMS

P. ADJOURNMENT

1. Adjourn to the next regular meeting dated November 20, 2013 starting at 7:00 p.m. on 1800 Willow Lake Rd – Located behind the Delta Community Presbyterian Church.

"This agenda shall be made available upon request in alternative formats to persons with a disability, as required by the American with Disabilities Act of 1990 (42 U.S.C. § 12132) and the Ralph M. Brown Act (California Government Code § 54954.2). Persons requesting a disability related modification or accommodation in order to participate in the meeting should contact the Town of Discovery Bay, at (925)634-1131, during regular business hours, at least twenty-four hours prior to the time of the meeting."

"Materials related to an item on the Agenda submitted to the Town of Discovery Bay after distribution of the agenda packet are available for public inspection in the District Office located at 1800 Willow Lake Road during normal business hours."



No Back Up
Documentation
For Agenda Item # C



No Back Up
Documentation
For Agenda Item # D



No Back Up
Documentation
For Agenda Item # E



DISCOVERY BAY PUBLIC FINANCING AUTHORITY

Chair – Mark Simon • Vice-Chair – Kevin Graves • Member – Bill Pease • Member – Chris Steele • Member – Marianne Wiesen

**MINUTES OF THE ANNUAL MEETING
OF THE MEMBERS OF THE
DISCOVERY BAY PUBLIC FINANCING AUTHORITY
Wednesday October 16, 2013
ANNUAL MEETING 7:00 P.M.
1800 Willow Lake Road, Discovery Bay, California
Website address: www.todb.ca.gov**

ANNUAL MEETING 7:00 P.M.

A. ROLL CALL AND PLEDGE OF ALLEGIANCE

Call business meeting to order – 7:00 p.m. by Chair Simon

Pledge of Allegiance – N/A

Roll Call – All Present

B. PUBLIC COMMENTS (Individual Public Comments will be limited to a 3-minute time limit)

None

C. NEW BUSINESS AND ACTION ITEMS

1. Status Report and Update of the Discovery Bay Public Financing Authority

General Manager Howard – Provided details of item C-1. There was discussion between the General Manager and the Board.

D. CHAIR'S REPORT AND MEMBER'S COMMENTS

None

E. ADJOURNMENT

The Public Financing Authority Annual Meeting adjourned at 7:03 p.m. at 1800 Willow Lake Road.

//cmc – 10.18.13

<http://www.todb.ca.gov/content/agenda-and-minutes/>



TOWN OF DISCOVERY BAY

A COMMUNITY SERVICES DISTRICT

President – Mark Simon • Vice-President – Kevin Graves • Director – Bill Pease • Director – Chris Steele • Director – Marianne Wiesen

**MINUTES OF THE REGULAR MEETING
OF THE BOARD OF DIRECTORS
OF THE TOWN OF DISCOVERY BAY
Wednesday October 16, 2013
REGULAR MEETING 7:00 P.M.
1800 Willow Lake Road, Discovery Bay, California
Website address: www.todb.ca.gov**

REGULAR MEETING 7:00 P.M.

A. ROLL CALL AND PLEDGE OF ALLEGIANCE

Call business meeting to order – 7:03 p.m. by President Simon
Pledge of Allegiance – Led by President Simon
Roll Call – All Present

B. PUBLIC COMMENTS (Individual Public Comments will be limited to a 3-minute time limit)

None

C. PRESENTATIONS

1. Brief Report Regarding the Wetlands

Doctoral Student Samantha Beardsley, University California Berkeley – Provided details of item C-1. There was discussion between the Board, the Water and Wastewater Manager, and Miss Beardsley.

D. PRESIDENT REPORT AND DIRECTORS' COMMENTS

The Board Members stated positive comments regarding the Rocktoberfest held at the Discovery Bay Community Center.

Director Pease – Provided his verbal report and the details of the Discovery Bay P6 Zone Citizen Advisory Committee meeting dated October 14, 2013

E. CONSENT CALENDAR

All matters listed under the CONSENT CALENDAR are considered by the District to be routine and will be enacted by one motion.

1. DRAFT minutes of previous regular meeting dated October 2, 2013

2. DRAFT minutes of previous special meeting dated October 9, 2013

3. Approve Register of District Invoices

Motion by: Vice-President Graves to approve the Consent Calendar with the exception of item E-3

Second by: Director Pease

Vote: Motion Carried – AYES: 5, NOES: 0

There was discussion between the Board and the General Manager regarding Agenda item E-3.

Motion by: Vice-President Graves to approve item E-3 of the Consent Calendar

Second by: Director Pease

Vote: Motion Carried – AYES: 5, NOES: 0

F. NEW BUSINESS AND ACTION ITEMS

1. Agency Comment Request – Development Plan Application – DP13-333 – Pacific/Bowie – Tracy II

General Manager Howard – Provided details of item F-1. There was discussion between the Board and the General Manager.

Motion by: Director Pease to send a letter to the County with no negative comments

Second by: Vice-President Graves

Vote: Motion Carried – AYES: 5, NOES: 0

2. Draft Request for Proposal regarding future consideration of the formation of a Town of Discovery Bay Strategic Plan

General Manager Howard – Provided details of item F-2. There was discussion between the General Manager and the Board.

There was no action taken by the Board on item F-2.

G. VEOLIA REPORT

1. Veolia Report for the Month of September 2013

Project Manager Fermin Garcia – Provided the details of the September 2013 Monthly Operations Report. There was discussion between the Project Manager and the Board.

H. MANAGER'S REPORTS

Water and Wastewater Manager Koehne – Provided an update on several Projects. There was discussion between the Board, the General Manager, and the Water and Wastewater Manager.

I. GENERAL MANAGER'S REPORT – Discussion and Possible Action

1. January 2014 Board of Directors Calendar

General Manager Howard – Provided details of item I-1 – The Board approved the change of the Board meetings to be the 2nd and 4th Wednesday for the month of January – Wednesday, January 8, 2014 and Wednesday, January 22, 2014.

J. DISTRICT LEGAL COUNSEL REPORT

None

K. COMMITTEE UPDATES – Discussion and Possible Action

1. Community Center Status Report (No written report)

None

L. CORRESPONDENCE – Discussion and Possible Action

1. R – East Contra Costa County Fire Protection District meeting minutes dated September 9, 2013
2. R – Contra Costa County Aviation Advisory meeting minutes dated September 12, 2013

M. PUBLIC RECORD REQUESTS RECEIVED

None

N. FUTURE AGENDA ITEMS

None

O. ADJOURNMENT

The meeting adjourned at 8:07 p.m. to the next Regular meeting dated November 6, 2013 starting at 7:00 p.m. on 1800 Willow Lake Road.

//cmc – 10.21.13

<http://www.todb.ca.gov/content/agenda-and-minutes/>



TOWN OF DISCOVERY BAY

A COMMUNITY SERVICES DISTRICT



President – Mark Simon • Vice-President – Kevin Graves • Director – Bill Pease • Director – Chris Steele • Director – Marianne Wiesen

**MINUTES OF THE JOINT MEETING OF THE
BOARD OF DIRECTORS AND COMMUNITY CENTER ADVISORY COMMITTEE
OF THE TOWN OF DISCOVERY BAY**

Wednesday, October 23, 2013

JOINT MEETING 6:30 p.m.

1800 Willow Lake Road, Discovery Bay, California

Website address: www.todb.ca.gov

Board of Directors

Mark Simon, President; Kevin Graves, Vice-President;
Bill Pease, Director; Chris Steele, Director; Marianne Wiesen, Director

Community Center Advisory Committee Members

Kevin Graves, Chair; Chris Steele, Vice-Chair; Diane Alexander, Paul Emmett, Kris Farro

JOINT MEETING OF THE BOARD OF DIRECTORS AND COMMUNITY CENTER ADVISORY COMMITTEE

A. ROLL CALL

Call business meeting to order – 6:30 p.m. by President Simon

Pledge of Allegiance – Led by Director Pease

Roll Call – All present with the exception of Director Steele and Member Farro

Director/Vice-Chair Steele – Arrived at 6:36 p.m.

Community Center Member Farro – Arrived at 6:41 p.m.

B. PUBLIC COMMENTS (Individual Public Comments will be limited to a 3-minute time limit)

None

C. PRESENTATIONS

1. Catherine Kutsuris, Director, Contra Costa County Department of Conservation and Development
 - Ms. Kutsuris will update the Board and Committee on the terms and conditions relative to the Contra Costa County, Hofmann Company, and Town of Discovery Bay Community Center Deal Points and related matters

General Manager Howard – Introduced Catherine Kutsuris, Director, Contra Costa County Department of Conservation and Development

Catherine Kutsuris, Director, Contra Costa County Department of Conservation and Development – Provided the details of item C-1. There was discussion between the Director, Contra Costa County Department of Conservation and Development, the Board, and the Community Center Committee.

D. PRESIDENT REPORT AND DIRECTORS' COMMENTS

Vice-President Graves – Provided his report for the East Contra Costa County Fire Protection District meeting dated October 7, 2013

Vice-President Graves – Provided his report for the Contra Costa County Aviation Advisory Committee meeting dated October 10, 2013

E. CONSENT CALENDAR

All matters listed under the CONSENT CALENDAR are considered by the District to be routine and will be enacted by one motion. This is an action of the Community Center Committee Only.

1. **DRAFT minutes of previous Community Center meeting dated September 10, 2013**

Motion by: Chair Graves to approve the Consent Calendar

Second by: Director Pease

Vote: AYES: 5, NOES: 0

F. NEW BUSINESS AND ACTION ITEMS

1. Summary of Community Center Building Considerations

General Manager Howard – Provided details of item F-1. There was discussion between the General Manager, the Community Center Committee, and the Board.

Motion by: Vice-President Graves to move forward with a not to exceed \$80,000.00 for the renovation and furnishing of the Community Center in order to operate as a Community Center

Second by: Director Wiesen

Vote: Motion Carried – AYES: 8, NOES: 0

2. Community Center Site Demand and Use Opportunities

General Manager Howard – Provided details of item F-2. There was discussion between the General Manager, the Parks and Landscape Manager, the Community Center Committee, and the Board.

3. Community Center Five-Year Financial Forecast for FY 2014/15 through FY 2018/19

General Manager Howard – Provided details of item F-3. Parks and Landscaping Manager provided additional details of item F-3. There was discussion between the General Manager, the Parks and Landscape Manager, the Community Center Committee, and the Board. There was one Public Comment Speaker.

4. Recreation Program and Newsletter

General Manager Howard – Provided details of item F-4. There was discussion between the General Manager, the Parks and Landscape Manager, the Community Center Committee, and the Board. There were two Public Comment Speakers.

5. Discussion and Consideration of a Plaque at the Discovery Bay Community Center

General Manager Howard – Provided details of item F-5. There was discussion between the General Manager, the Parks and Landscape Manager, the Community Center Committee, and the Board. There was one Public Comment Speaker. The Board of Directors and the Community Center Committee took no action on item F-5.

6. Concrete Pad at the Community Center

General Manager Howard – Provided details of item F-6. There was discussion between the General Manager and the Board. Staff will proceed with replacing the gravel portion of the driveway with concrete in the amount of \$5,250.00

G. FUTURE AGENDA ITEMS

None

H. ADJOURNMENT

The meeting adjourned at 8:28 p.m. to the next Board of Directors and Community Center Committee Joint meeting at 1800 Willow Lake Road.

//cmc – 10.24.13

<http://www.todb.ca.gov/content/agenda-and-minutes/>



Town of Discovery Bay

"A Community Services District"

AGENDA REPORT

Meeting Date

November 06, 2013

Prepared By: Dina Breitstein, Finance Manager & Lesley Marable, Sr. Accounts Clerk
Submitted By: Rick Howard, General Manager *RH*

Agenda Title

Approve Register of District Invoices

Recommended Action

Staff recommends that the Board approve the listed invoices for payment

Executive Summary

District invoices are paid on a regular basis, and must obtain Board authorization prior to payment. Staff recommends Board authorization in order that the District can continue to pay warrants in a timely manner.

Fiscal Impact:

Amount Requested \$ 171,263.63

Sufficient Budgeted Funds Available?: Yes (If no, see attached fiscal analysis)

Prog/Fund # See listing of invoices. **Category:** Operating Expenses and Capital Improvements

Previous Relevant Board Actions for This Item

Attachments

Request For Authorization to Pay Invoices for the Town of Discovery Bay CSD 2013/2014
Request For Authorization to Pay Invoices for the Discovery Bay Lighting & Landscape District # 8 2013/2014
Request For Authorization to Pay Invoices for the Discovery Bay Lighting & Landscape District # 9 2013/2014

AGENDA ITEM: F-4

Request for authorization to pay invoices (RFA)
For the Meeting on November 06, 2013
Town of Discovery Bay CSD
For Fiscal Year's 7/13 - 6/14

<u>Vendor Name</u>	<u>Invoice Number</u>	<u>Description</u>	<u>Invoice Date</u>	<u>Amount</u>
Administration				
Bill Pease	OCT 2013	Expense Report Oct 2013	10/29/13	\$690.00
Caselle, Inc.	52838	Online/Electronic Payments Application	10/28/13	\$3,000.00
Cash	OCT 2013	Petty Cash Reimb. (Community Center)	10/28/13	\$294.28
Cash	OCT 2013	Petty Cash Reimb.	10/28/13	\$184.26
Chris Steele	OCT 2013	Expense Report Oct 2013	10/29/13	\$694.52
County Of Contra Costa, Dept of Info Tec	8449	Data Processing Sept 2013	10/22/13	\$44.00
Dina Breitstein	OCT 2013	Expense Report Oct 2013	10/30/13	\$81.59
Express Employment Professionals	13086332-7	Admin Asst Week Ending 09/22/13 (Z61)	09/25/13	\$119.35
Express Employment Professionals	13119226-2	Admin Asst Week Ending 09/29/13 (Z57, Z61)	10/02/13	\$381.92
Freedom Mailing Service, Inc	23376	Bill Processing Sept 2013	10/10/13	\$1,142.54
Lesley Marable	OCT 2013	Expense Report Oct 2013	10/28/13	\$52.55
Marianne Wiesen	OCT 2013	Expense Report Oct 2013	10/29/13	\$460.00
Mark Simon	OCT 2013	Expense Report Oct 2013	10/29/13	\$500.00
Neopost (Postage Account)	7900044908384658/113	Postage and Supplies	10/07/13	\$231.15
Neumiller & Beardslee	258602	Hofmann v. TODB	10/15/13	\$688.75
Odyssey Landscape Co, Inc.	36039236.1	Misc. Irrigation Repairs (Z57,Z61)	09/30/13	\$665.00
Office Depot	667610339001	Office Supplies	10/10/13	\$50.83
Office Depot	667610383001	Office Supplies	10/10/13	\$4.33
Office Depot	673806895001	Office Supplies	10/04/13	\$66.60
Office Depot	678473791001	Office Supplies	09/27/13	\$144.97
Office Depot	679321700001	Office Supplies	10/18/13	\$133.34
Office Depot	679321764001	Office Supplies	10/18/13	\$35.09
ReliaStar Life Insurance Company	JR52 457(B) 10/31/13	457(b) 10/16/13-10/31/13	10/28/13	\$849.56
Ricoh USA, Inc	5028027263	Photocopier	10/20/13	\$21.22
Robert Capp Construction, Inc	2427(B)	District Office Ramp Retention	01/15/13	\$1,618.60
SDRMA	13524	Ancillary Benefits Nov 2013	10/25/13	\$632.06
SDRMA	44407	Reconciled Workers Comp 2012-2013	08/26/13	\$2,780.47
SDRMA	45223	Certificate of Insurance Request (Z35,Z57,Z61)	10/02/13	\$125.00
Shred-It	9402620905	Shredding Service 10/03/13	10/03/13	\$59.92
Some Gave All	OCT 2013	Expense Report Oct 2013	10/29/13	\$744.25
Verizon Wireless	9712305695	Cell Phone Bill Sept 2013	09/26/13	\$131.80
		Administration	Sub-Total	\$16,627.95
Water				
American Retrofit Systems	391	Replace Flag Pole Light and Photo Cell	10/18/13	\$70.00
Cash	OCT 2013	Petty Cash Reimb.	10/28/13	\$5.96
Contra Costa Health Services	IN0135511	Health Permit Newport Dr	10/22/13	\$1,368.00
Contra Costa Health Services	IN0135592	Health Permit Willow Lake Rd	10/22/13	\$1,368.00
Contra Costa Health Services	IN135421	Health Permit Well #5	10/21/13	\$377.00
Discovery Pest Control	499979	Pest Control	10/07/13	\$14.00
Express Employment Professionals	13086332-7	Admin Asst Week Ending 09/22/13	09/25/13	\$95.48
Express Employment Professionals	13119226-2	Admin Asst Week Ending 09/29/13	10/02/13	\$106.28
J.W. Backhoe & Construction, Inc.	1982	Water Leak on Beaver Court	10/10/13	\$3,829.80
J.W. Backhoe & Construction, Inc.	1984	Water Leak Discovery Bay Blvd	10/10/13	\$3,393.85
J.W. Backhoe & Construction, Inc.	1985	Sealed Cracks	10/10/13	\$781.75
J.W. Backhoe & Construction, Inc.	1989	Paved 5 Spots	10/16/13	\$5,489.73
Luhdorff & Scalmanini	29143	Water Level Monitoring Program	09/29/13	\$922.95
Luhdorff & Scalmanini	29145	Well 1B	09/29/13	\$1,990.00
Pacific Gas & Electric	2943721807-5/1013	Electric & Gas Bill 09/10/13-10/08/13	10/16/13	\$33,137.98
ReliaStar Life Insurance Company	JR52 457(B) 10/31/13	457(b) 10/16/13-10/31/13	10/28/13	\$50.00
SDRMA	13524	Ancillary Benefits Nov 2013	10/25/13	\$4.28
SDRMA	44407	Reconciled Workers Comp 2012-2013	08/26/13	\$778.20
Univar	SJ580476	Chemicals Delivered 10/04/13	10/04/13	\$296.57
Univar	SJ580500	Chemicals Delivered 10/04/13	10/04/13	\$178.44
Univar	SJ582116	Chemicals Delivered 10/10/13	10/10/13	\$242.02
Univar	SJ582117	Chemicals Delivered 10/10/13	10/10/13	\$143.57
Univar	SJ582888	Chemicals Delivered 10/17/13	10/17/13	\$258.43
Univar	SJ582889	Chemicals Delivered 10/17/13	10/17/13	\$168.18
UPS	000012X417413	Shipping Cost	10/12/13	\$15.47
Veolia Water North America	32128	Monthly R & M Sept 2013	10/18/13	\$397.84
Veolia Water North America	32128	Monthly R & M Sept 2013	10/18/13	\$3,770.00
Verizon Wireless	9712305695	Cell Phone Bill Sept 2013	09/26/13	\$139.75

Water Sub-Total \$59,393.53

Wastewater

A & L Western Agricultural Labs, Inc.	155196	Testing of Bio-Solids	10/22/13	\$400.00
American Retrofit Systems	390	Replace Plug and Wire on Dump Trailer	10/15/13	\$185.00
American Retrofit Systems	391	Replace Flag Pole Light and Photo Cell	10/18/13	\$105.00
Contra Costa Health Services	IN0135419	Health Permit WWTP#2	10/22/13	\$377.00
Contra Costa Health Services	IN0135420	Health Permit WWTP#1	10/22/13	\$377.00
Discovery Pest Control	499979	Pest Control	10/07/13	\$21.00
Express Employment Professionals	13086332-7	Admin Asst Week Ending 09/22/13	09/25/13	\$143.22
Express Employment Professionals	13119226-2	Admin Asst Week Ending 09/29/13	10/02/13	\$159.42
J.W. Backhoe & Construction, Inc.	1987	Picked up and Spread Bio Solids	10/10/13	\$5,400.00
Pacific Gas & Electric	7312115758-7/1013	Electric & Gas Bill	10/16/13	\$33,111.15
Phil's Diesel Clinic, Inc	56468	Generator Service	05/15/13	\$2,512.39
ReliaStar Life Insurance Company	JR52 457(B) 10/31/13	457(b) 10/16/13-10/31/13	10/28/13	\$75.00
SDRMA	13524	Ancillary Benefits Nov 2013	10/25/13	\$1.84
SDRMA	44407	Reconciled Workers Comp 2012-2013	08/26/13	\$1,167.31
SDRMA	45223	Certificate of Insurance Request	10/02/13	\$125.00
Veolia Water North America	32128	Monthly R & M Sept 2013	10/18/13	\$2,823.99
Veolia Water North America	32128	Monthly R & M Sept 2013	10/18/13	\$29,402.65
Verizon Wireless	9712305695	Cell Phone Bill Sept 2013	09/26/13	\$98.36

Wastewater Sub-Total \$76,485.33

Community Center

Community Center Sub-Total \$0.00

Grand Total \$152,506.81

Request For Authorization To Pay Invoices (RFA)
For the Meeting on November 06, 2013
Town of Discovery Bay, D.Bay L&L Park #8
For Fiscal Year's 7/13 - 6/14

<u>Vendor Name</u>	<u>Invoice Number</u>	<u>Description</u>	<u>Invoice Date</u>	<u>Amount</u>
American Retrofit Systems	389	Replace 6 Ballast	10/15/13	\$2,300.00
Commercial Tree Care	16909	Large Palm Tree Trimming	09/18/13	\$2,970.00
Delta Debris Box Service	861894	Community Center-40 Yd & Rcts Box	09/30/13	\$869.06
Express Employment Professionals	13086332-7	Admin Asst Week Ending 09/22/13	09/25/13	\$238.70
Express Employment Professionals	13086332-7	Community Center-Admin Asst Week Ending 09/22/13	09/25/13	\$155.16
Express Employment Professionals	13119226-2	Community Center-Admin Asst Week Ending 09/29/13	10/02/13	\$74.45
Lincoln Equipment, Inc.	51226057	Community Center-Chemicals For Pool	10/14/13	\$325.47
Odyssey Landscape Co, Inc.	36039233.1	Repair Mainline Discovery Bay Blvd	09/30/13	\$1,790.00
Odyssey Landscape Co, Inc.	36039236.1	Misc. Irrigation Repairs	09/30/13	\$420.00
Office Depot	678473791001	Office Supplies	09/27/13	\$67.84
Pacific Gas & Electric	0869258994-1/1013	Electric & Gas Bill 09/10/13-10/08/13	10/08/13	\$411.08
Pacific Gas & Electric	57028395898-6/1013	Electric & Gas Bill 09/09/13-10/07/13	10/17/13	\$862.95
Pacific Gas & Electric	5939734421-5/1013	Electric & Gas Bill 09/15/13-10/15/13	10/15/13	\$6,409.87
SDRMA	44407	Reconciled Workers Comp 2012-2013	08/26/13	\$501.00
Verizon Wireless	9712305695	Cell Phone Bill Sept 2013	09/26/13	\$381.22
			Total	\$17,776.80

Request For Authorization To Pay Invoices (RFA)
For the Meeting on November 06, 2013
Town of Discovery Bay, D.Bay L&L Park #9 (Ravenswood)
For Fiscal Year's 7/13 - 6/14

<u>Vendor Name</u>	<u>Invoice Number</u>	<u>Description</u>	<u>Invoice Date</u>	<u>Amount</u>
Discovery Pest Control	499979	Pest Control	10/07/13	\$35.00
Express Employment Professionals	13086332-7	Admin Asst Week Ending 09/22/13	09/25/13	\$190.96
Express Employment Professionals	13119226-2	Admin Asst Week Ending 09/29/13	10/02/13	\$95.48
Odyssey Landscape Co, Inc.	36039236.1	Misc. Irrigation Repairs	09/30/13	\$70.00
Office Depot	678473791001	Office Supplies	09/27/13	\$67.85
Office Depot	678474383001	Office Supplies	09/27/13	\$16.55
Pacific Gas & Electric	0403377952-3/1013	Electric & Gas Bill 09/09/13-10/07/13	10/08/13	\$44.20
SDRMA	44407	Reconciled Workers Comp 2012-2013	08/26/13	\$334.00
Verizon Wireless	9712305695	Cell Phone Bill Sept 2013	09/26/13	\$125.98
			Total	\$980.02



Town of Discovery Bay

"A Community Services District"

AGENDA REPORT

Meeting Date

November 6, 2013

Prepared By: Fairin Perez, Parks and Landscape Manager

Submitted By: Rick Howard, General Manager

RH

Agenda Title

Purchase video surveillance system for the Discovery Bay Community Center

Recommended Action

That the Board authorize, as follows: 1) Approve purchase and installation of Bosch Camera and Smart Alerting System by West Coast Security at the Discovery Bay Community Center and authorize the General Manager to execute a purchase order based on the proposal from West Coast Security in the amount of \$7,574.03; and 2) Approve miscellaneous expense up to \$750.00 for the installation of video and or audio network cabling as needed at the Community Center.

Executive Summary

Since the Town of Discovery Bay purchased the Community Center, there have been numerous occasions of theft and vandalism. The building itself is alarmed and monitored during non-operational hours, but the grounds (swimming pool, tennis courts and open areas) are left without formal security measures.

In August alone, three separate incidents of vandalism and/or attempts at entry were made. On August 17th, unknown suspects entered the pool area and caused an estimated \$2,200.00 in damages to the swim deck and pathway lighting (Sheriff Report 13-14503). On both August 27th and 29th there was attempted entry into the Community Center building; both ending in broken windows at the facility (Sheriff Reports No. 13-15083 and 13-15127). Window replacements average \$250.00 each.

Video Surveillance Systems and security has also recently been an issue for the Water and Wastewater Department. Significant research on the specifications and capabilities of various systems were compared for use at these facilities. The District's Engineer, HERWIT Engineering met with staff to identify video surveillance systems that would work for not only the Water & Wastewater Facilities but also at the Community Center. A system capable of providing a high resolution camera imaging both in daylight and at night; at least 7 days of back up recording; the capability to discern human, vehicle intrusion vs. regular motion detection; and the ability to provide instant alerts via smart phone applications is desirable.

The equipment that meets the functions as noted above are the VideoIQ and Bosch Camera systems. Both systems allow constant "intelligent" monitoring and alerting without the pricey monthly monitoring service charges that can be associated with other systems. Both systems are internet based, allowing users to log in from their phone, laptop, personal computer, etc. The smart analytics can distinguish human and vehicle intrusion (different method for each system) and when triggered, will send an instant alert. The cameras can be programmed with site specific information, such as setting sensitive areas, times for alerts, defining users who receive alerts and will even allow you to connect to a commercial grade outdoor speaker attached to the units to speak directly to intruders.

Current users of the VideoIQ system include the Selma-Kingsburg-Fowler Sanitation District, Caltrans and the Redwood City Police Department; all of which were contacted and provided positive references for the product. Users of the Bosch Camera System include several police departments in the Bay Area and several Veterans Affairs facilities in the Bay Area. Virgil Koehne and HERWIT Engineering witnessed a demonstration of the Bosch Camera system in Livermore. A Bosch trial camera system is currently on loan to the Town of Discovery Bay.

Both of the preferred systems quoted are similar in video imaging and recording capabilities, and both offer smart alerting function makes. The Bosch camera system is a true starlight camera system able to operate with no external lighting, and has autofocus, but with slightly lower resolution and less video storage. The Video IQ camera has higher resolution and more on camera video storage. Pricing is less for the Bosch camera system.

-Continued-

Proposal Comparison:

Specifications	VideolQ by QPCS	IP3MP by Denalect	Bosch by West Coast Security	Video IQ by AMS.NET
Internet Access	YES	YES	YES	YES
30 Day Recording	YES (On Camera)	YES (With NVR)	7days on Camera Or 30 days with (NVR for additional cost)	YES (On Camera)
Smart Alerting	YES	NO	YES	YES
Audio @ Site	YES (\$450.00)	YES (\$2,000.00)	YES (\$3,852.00)	NOT Quoted
Resolution	3MP	3 MP	2 MP	3 MP
Night Capability	Yes - Req ambient light	Yes - Req ambient light	Yes - Starlight , no ambient lighting required.	Yes – Req ambient light
Warranty	2 Years	1 Year	2 Years	1 Year
Camera Quantity	3	3	3	3
Cost	\$9463.33 (\$9913.33 w Audio)	\$6499.00 (8499.00 w/Audio)	\$7,574.03 (\$11,425.62 w Audio)	\$9,368.42

To simplify quotes, none of the quotes include routing network cabling through the Community Center to connect the cameras. A budget of \$500.00 for cabling and labor is included for this task. This task will be performed by the Town.

The audio quotes vary because of the quality and power levels of the sound systems, with the system from West Coast being much higher power than from QPCS.

No budgetary funding was identified for a video surveillance system at the Community Center for FY 2013-14. There are, however, funds available within the Community Center Fund identified for future Capital Improvements/Replacement of the facility. Since this system will easily integrate into a new facility (or remodeled building), and would have been considered in the costs associated with those future improvements, staff recommends using the Capital Improvement funds for this purchase.

Staff further recommends approving the installation of the Bosch Camera system at the Discovery Bay Community Center and authoring the General Manager to execute a purchase order based on the proposals from West Coast Security, in the amount of \$7,574.03. Staff further recommends approving installation of network Cabling by Town staff to support the camera system at the Discovery Bay Community Center, in the amount up to \$750.00

Staff does not recommend the installation of the audio component of the system at this time. Based on cost, staff recommends testing different options once the surveillance system is in place and operational. The Board does have the ability, however, to authorize the system as presented at an additional cost of \$3,851.59.

Fiscal Impact:

Amount Requested - \$8,325.00
 Sufficient Budgeted Funds Available?: No
 Zone #Community Center Fund Category: Capital (Community Center Fund)

Previous Relevant Board Actions for This Item

None

Attachments

Sheriff Report No.(s) 13-14503, 13-15083 and 13-15227
 QPCS Proposal No. 240, with attached technical information
 Denalect Alarm CCTV Quotation dated 9-16-13, with attached technical information
 West Coast Security Proposal WSCQ102113-1CB Revision 1 and WSCQ103113-2CB with attached technical information
 AMS.net Price Quote order #79744

OFFICE OF THE SHERIFF, CONTRA COSTA COUNTY CA0070000
P.O. Box 391, Martinez, California 94553-0039

- Face Page
- Continuation
- Supplemental

- D.V.
- HRO
- Arrest
- SI

1. DR No. 13-14503		2. City Code DEL		3. Crime/Classification VANDALISM FELONY			4. Detail 1. 594F 2.		5. More Persons <input type="checkbox"/>		
6. Day / Date / Time of Occurrence From SAT 08/17/2013 2000 To SUN 08/18/2013 1100					7. Date / Time Reported 08/19/2013 / 1442		8. Employee No. 64742		9. Reclassification <input type="checkbox"/>		
10. Address / Location of Occurrence 1601 Discovery Bay Blvd						City Discovery Bay		State CA	Zip 94505		
11. <input checked="" type="checkbox"/> PRI <input type="checkbox"/> VIC <input type="checkbox"/> WIT <input type="checkbox"/> MSP <input type="checkbox"/> RUN <input type="checkbox"/> SUS <input type="checkbox"/> LEAD <input type="checkbox"/> OTHER											
12. Name (L, F, M) Cardwell			Type: <input type="checkbox"/> Business <input checked="" type="checkbox"/> Individual <input type="checkbox"/> Government Cory			13. Race / Sex / Age W / M		14. DOB		15. Driver License No/State	
16. Address Street						City		State	Zip		
17. Home Phone						18. Employed By or School					
19. Work Phone	20. Hair BLN		21. Eyes BLU	22. Ht. 601	23. Wt. 235	24. AKA / Maiden Name			25. Social Security No.		
26. Further Description (Scars, Tattoos, Mannerisms, Clothing, Etc.)						Cell Phone		27. Booking or Cite No.			
28. <input type="checkbox"/> PRI <input checked="" type="checkbox"/> VIC <input type="checkbox"/> WIT <input type="checkbox"/> MSP <input type="checkbox"/> RUN <input type="checkbox"/> SUS <input type="checkbox"/> LEAD <input type="checkbox"/> OTHER											
29. Name (L, F, M) Discovery Bay					Type: <input type="checkbox"/> Business <input type="checkbox"/> Individual <input checked="" type="checkbox"/> Government Town of		30. Race / Sex / Age / /		31. DOB	32. Driver License No/State	
33. Address Street 1601 Discovery Bay Blvd						City Discovery Bay		State CA	Zip 94505		
34. Home Phone						35. Employed By or School					
36. Work Phone	37. Hair		38. Eyes	39. Ht.	40. Wt.	41. AKA / Maiden Name			42. Social Security No.		
43. Further Description (Scars, Tattoos, Mannerisms, Clothing, Etc.) Community Park/Pool area.						Cell Phone		44. Booking or Cite No.			
45. <input type="checkbox"/> PRI <input type="checkbox"/> VIC <input type="checkbox"/> WIT <input type="checkbox"/> MSP <input type="checkbox"/> RUN <input type="checkbox"/> SUS <input type="checkbox"/> LEAD <input type="checkbox"/> OTHER											
46. Name (L, F, M)					Type: <input type="checkbox"/> Business <input checked="" type="checkbox"/> Individual <input type="checkbox"/> Government			47. Race / Sex / Age / /		48. DOB	49. Driver License No/State
50. Address Street						City		State	Zip		
51. Home Phone						52. Employed By or School					
53. Work Phone	54. Hair		55. Eyes	56. Ht.	57. Wt.	58. AKA / Maiden Name			59. Social Security No.		
60. Further Description (Scars, Tattoos, Mannerisms, Clothing, Etc.)						Cell Phone		61. Booking or Cite No.			
62. Veh / Ves <input type="checkbox"/> S <input type="checkbox"/> Vict		63. Lic No. (State)		64. Year	65. Make	66. Model		67. Body Style	68. Color Top Bottom		
69. Status <input type="checkbox"/> Left <input type="checkbox"/> Impound <input type="checkbox"/> Stored		70. Registered Owner				71. R.O. Address					
72. Towed to or Released to						73. Who has Keys?					
74. Evid <input type="checkbox"/> Yes <input checked="" type="checkbox"/> No		75. F / P <input type="checkbox"/> Yes <input checked="" type="checkbox"/> No		76. Dispo of Evidence 3 Digital Photos Attached			77. Missing		78. Damaged \$2,200.00		
79. Brief Synopsis of Incident This report concerns a vandalism at 1601 Discovery Bay Blvd. In Discovery Bay (Community Park/Pool Area) where PRI-Cory Cardwell (Town worker) said several lamps were broken and there was damage to the edge of the pool. Cardwell estimates damages at \$2,200.00. There are no alarms or video surveillance at the above listed location. I took three digital photographs of the reported damage and they are attached to this report. There are no suspects, witnesses or leads to this crime.											
<p>CONTROLLED DOCUMENT Office of the Sheriff Contra Costa County</p> <p>SEP 13 2013</p> <p><i>[Signature]</i></p>											
<p>in-car video <input type="checkbox"/> Yes <input checked="" type="checkbox"/> No</p>											
MARSYS LAW <input checked="" type="checkbox"/> Yes <input type="checkbox"/> No			ELDER ABUSE FORM SOC 341 <input type="checkbox"/> Yes <input checked="" type="checkbox"/> No			VICTIM RESPONSE - 293 PC <input type="checkbox"/> Yes <input checked="" type="checkbox"/> No					
80. Distribution <input type="checkbox"/> B <input type="checkbox"/> C <input type="checkbox"/> DA <input type="checkbox"/> DE <input type="checkbox"/> L <input type="checkbox"/> O <input type="checkbox"/> MOTCO <input checked="" type="checkbox"/> Investigation <input type="checkbox"/> MP <input checked="" type="checkbox"/> HSU/APT <input type="checkbox"/> V <input type="checkbox"/> Coroner <input type="checkbox"/> Property Ck. <input type="checkbox"/> Patrol Clerk <input type="checkbox"/> R.O. <input type="checkbox"/> SHC <input type="checkbox"/> Patrol Captain <input type="checkbox"/> Misd.Comp. <input checked="" type="checkbox"/> Crime Analysis <input type="checkbox"/> OAK						81. Additional Routing					
82. Reporting Deputy (Print) Daniel Jordan						83. Date/Time Written 08/20/2013 / 1626		84. Dispo REF			
85. Approving Supv (Print) Connie Sanders						86. Supv No. 66580		87. Date 08/20/2013			

Continuation
 Supplemental

OFFICE OF THE SHERIFF, CONTRA COSTA COUNTY CA0070000
P.O. Box 391, Martinez, CA 94553-0039

Beat 32

D.V. HRO Arrest SI

1. DR No. 13-14503	2. City Code DEL	3. Crime / Classification VANDALISM FELONY	4. Detail 1. 594F 2.	5. Reclassification <input type="checkbox"/>
6. Victim Name (L,F,M) Discovery Bay		Type: <input type="radio"/> Business <input type="radio"/> Individual <input checked="" type="radio"/> Government Town of	7. Date Orig. Report 08/19/2013	8. Employee No. 64742
9. Address / Location of Occurrence 1601 Discovery Bay Blvd		City Discovery Bay	State CA	Zip 94505
10. Suspect's Name (L,F,M) Type: <input type="radio"/> Business <input checked="" type="radio"/> Individual <input type="radio"/> Government				

11. Property Description:
Impounded, Recovered, Found, Lost, Stolen - Item Number, Article, Quantity, Brand/Make/Manufacturer's Model Number, Serial Number, Miscellaneous Description, Location Where Taken, Value, Includes Total Loss - LIST IN FOLLOWING ORDER: A) Currency, Notes: B) Jewelry; C) Furs; D) Vehicles; E) Office Equipment; F) Radio, TVs etc.; G) Firearms; H) Household Goods; I) Misc.

12. Recovered Property \$
13. Narrative / Statements

On 8-19-13 I was dispatched to a reported vandalism at 1601 Discovery Bay Blvd. in Discovery Bay (Community park/ pool area) where I met PRI-Cory Gardwell. Gardwell told me the following in summary:

Cardwell said he works for the Town of Discovery Bay and was in charge of locking/closing the community park/pool on 8-17-13. Cardwell told me he closed the facility at approx 2000 hours. Cardwell said he reopened the community park/pool on 8-18-13 at approx 1100 hours and noticed damage to the outdoor lamps.

As Cardwell looked around the community park/pool area, he noticed the "bulbs" were broken off the light posts and the electrical wires were now exposed (see attached photo). Cardwell said after further investigation, he noticed a total six (6) lamps broken. Cardwell also said he noticed the "bull nose" edge of the pool broken off as well and the umbrella stands thrown into the pool water (8 umbrella stands). Cardwell said, at the time of this report, it could not be determined if the the umbrella stands caused damage to the bottom of the pool, due to it being filled with water. Cardwell told me each of the umbrella stands weighs approximately 25 pounds.

Cardwell said he received an estimate of approximately \$200.00 (each) to fix the six (6) lamps throughout the park/pool area, totaling \$1,200.00. Cardwell also said the 12" section of the "bull nose" edge of the pool is estimated at approximately \$1,000.00.

Cardwell said the Town of Discovery Bay does desire prosecution if the unknown suspect(s) are located.

There are no alarms and no video surveillance on the park property.

I took three digital photos; First photo is what the Lamp Light looks like without damage, Second photo shows vandalism done to each lamp and the third photo shows the broken "bull nose" edge of pool.

There are no suspects, witnesses or leads to this crime.

DAMAGE:

- (6) Black lamp post with 18" white frosted Bulb covers. Estimated Repair:\$1,200.00
- (1) 12" Section of concrete of pool ("Bull nosed" edge) Estimated Repair:\$1,000.00

Estimated Total Repair: \$2,200.00

CONTROLLED DOCUMENT
Office of the Sheriff
Contra Costa County

SEP 13 2013

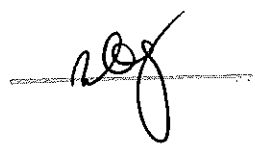

14. Distribution <input type="checkbox"/> B <input type="checkbox"/> C <input type="checkbox"/> DA <input type="checkbox"/> DE <input type="checkbox"/> L <input type="checkbox"/> O <input type="checkbox"/> MOTCO <input checked="" type="checkbox"/> Investigation <input type="checkbox"/> MP <input checked="" type="checkbox"/> HSU/IPT <input type="checkbox"/> V <input type="checkbox"/> Coroner <input type="checkbox"/> Property Clk. <input type="checkbox"/> Patrol Clerk <input type="checkbox"/> R.O. <input type="checkbox"/> SHC <input type="checkbox"/> Patrol Captain <input type="checkbox"/> Misd.Comp. <input checked="" type="checkbox"/> Crime Analysis <input type="checkbox"/> OAK	15. Additional Routing	16. Reporting Deputy (Print) Daniel Jordan	17. Date/Time Written 08/20/2013 / 1626	18. Dispo REF
		19. Approving Supv (Print) Connie Sanders	20. Supv No. 66580	21. Date 08/20/2013

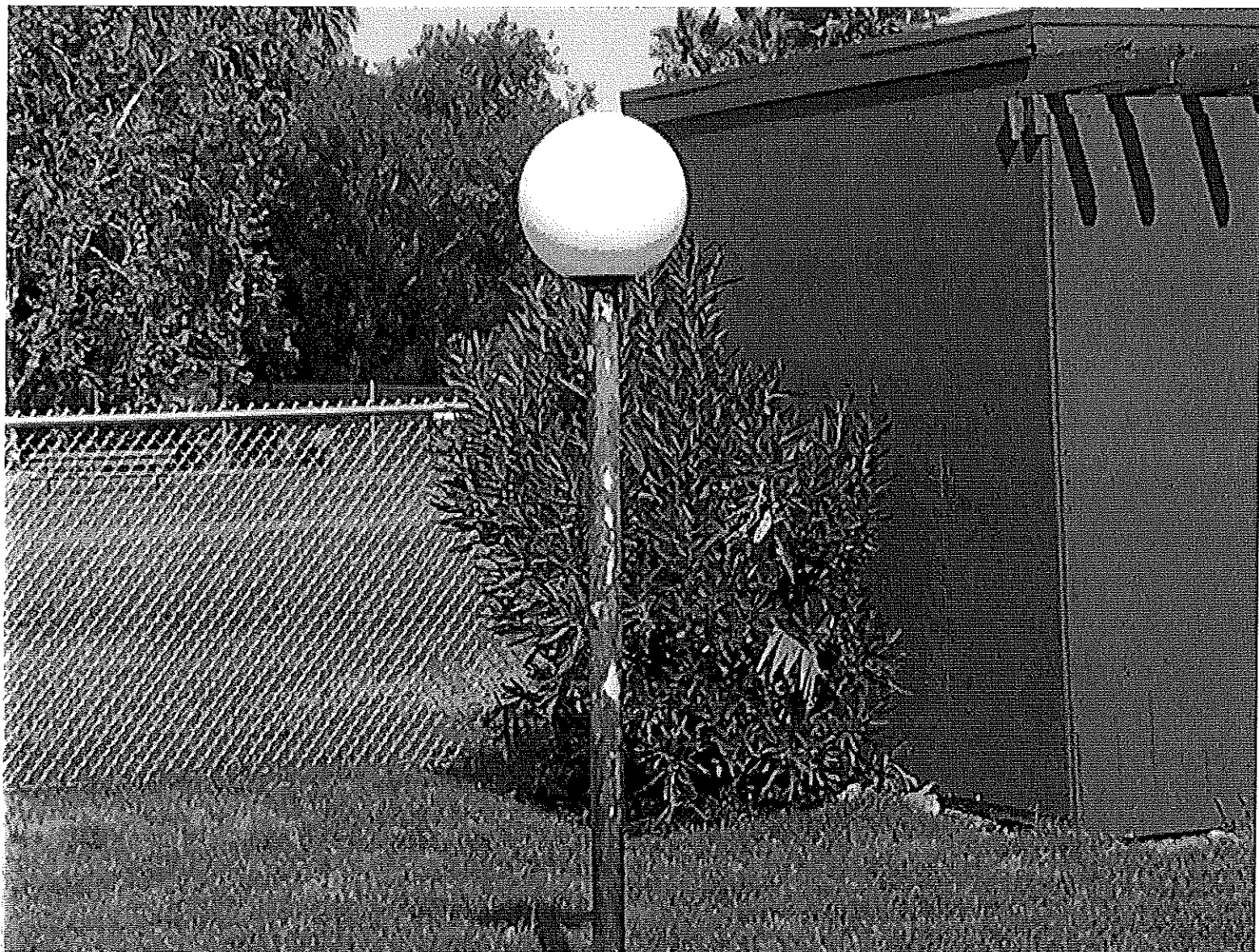

CONTROLLED DOCUMENT
Office of the Sheriff
Contra Costa County

SEP 13 2013

[Handwritten signature]



CONTROLLED DOCUMENT
Office of the Sheriff
Contra Costa County

SEP 13 2013

[Handwritten signature]

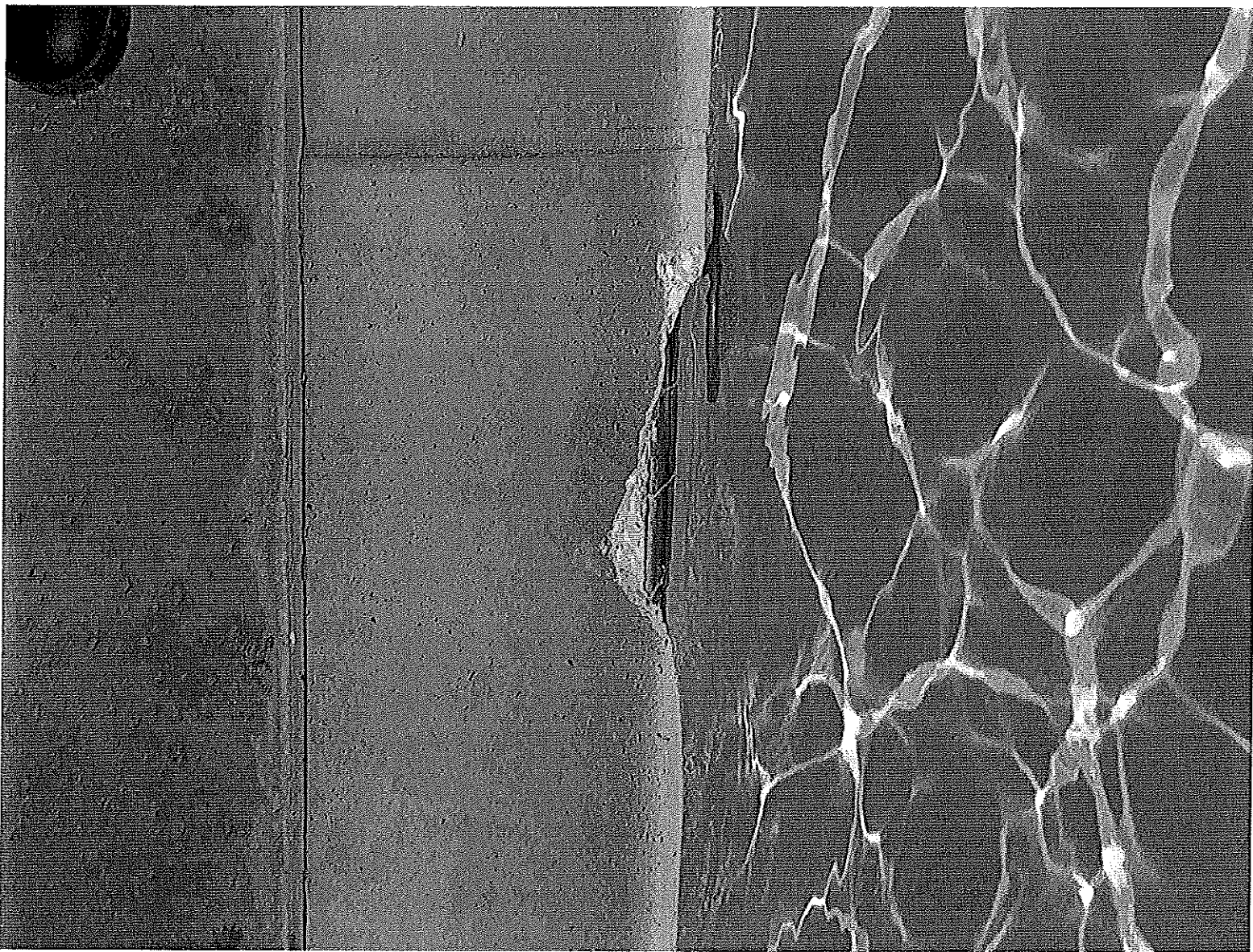

CONTROLLED DOCUMENT
Office of the Sheriff
Contra Costa County

SEP 13 2013

[Handwritten signature]

Face Page
 Continuation
 Supplemental

OFFICE OF THE SHERIFF, CONTRA COSTA COUNTY CA0070000
P.O. Box 391, Martinez, California 94553-0039

Beat 32

D.V. HRO Arrest SI

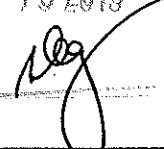
1. DR No. 13-15083		2. City Code DEL		3. Crime/Classification VANDALISM MISDEMEANOR			4. Detail 1. 594M 2.		5. More Persons <input type="checkbox"/>		
8. Day / Date / Time of Occurrence From TUE 08/27/2013 1800 To WED 08/28/2013 0645				7. Date / Time Reported 08/28/2013 / 0743			8. Employee No. 61600		9. Reclassification <input type="checkbox"/>		
10. Address / Location of Occurrence 1601 Discovery Bay Blvd						City Discovery Bay		State CA	Zip 94505		
11. <input checked="" type="checkbox"/> PRI <input type="checkbox"/> VIC <input type="checkbox"/> WIT <input type="checkbox"/> MSP <input type="checkbox"/> RUN <input type="checkbox"/> SUS <input type="checkbox"/> LEAD <input type="checkbox"/> OTHER											
12. Name (L, F, M) Rocha				Type: <input type="checkbox"/> Business <input checked="" type="checkbox"/> Individual <input type="checkbox"/> Government Estevan		13. Race / Sex / Age H / M		14. DOB		15. Driver License No/State	
16. Address Street						City		State	Zip		
17. Home Phone						18. Employed By or School		19. Work Phone			
20. Hair BLK		21. Eyes BRO	22. Ht. 511	23. Wt. 250	24. AKA / Maiden Name			Email Address		25. Social Security No.	
26. Further Description (Scars, Tattoos, Mannerisms, Clothing, Etc.)							Cell Phone		27. Booking or Cite No.		
28. <input type="checkbox"/> PRI <input checked="" type="checkbox"/> VIC <input type="checkbox"/> WIT <input type="checkbox"/> MSP <input type="checkbox"/> RUN <input type="checkbox"/> SUS <input type="checkbox"/> LEAD <input type="checkbox"/> OTHER											
29. Name (L, F, M) Discovery Bay				Town of Town of		30. Race / Sex / Age / /		31. DOB		32. Driver License No/State	
33. Address Street 1601 Discovery Bay Blvd						City Discovery Bay		State CA	Zip 94505		
34. Home Phone						35. Employed By or School		36. Work Phone 925-634-1131			
37. Hair		38. Eyes	39. Ht.	40. Wt.	41. AKA / Maiden Name			Email Address		42. Social Security No.	
43. Further Description (Scars, Tattoos, Mannerisms, Clothing, Etc.)							Cell Phone		44. Booking or Cite No.		
45. <input type="checkbox"/> PRI <input type="checkbox"/> VIC <input type="checkbox"/> WIT <input type="checkbox"/> MSP <input type="checkbox"/> RUN <input type="checkbox"/> SUS <input type="checkbox"/> LEAD <input type="checkbox"/> OTHER											
46. Name (L, F, M)				Type: <input type="checkbox"/> Business <input checked="" type="checkbox"/> Individual <input type="checkbox"/> Government		47. Race / Sex / Age / /		48. DOB		49. Driver License No/State	
50. Address Street						City		State	Zip		
51. Home Phone						52. Employed By or School		53. Work Phone			
54. Hair		55. Eyes	56. Ht.	57. Wt.	58. AKA / Maiden Name			Email Address		59. Social Security No.	
60. Further Description (Scars, Tattoos, Mannerisms, Clothing, Etc.)							Cell Phone		61. Booking or Cite No.		
62. Veh / Ves <input type="checkbox"/> S <input type="checkbox"/> Vict		63. Lic No. (State) n/a		64. Year	65. Make		66. Model		67. Body Style	68. Color Top Bottom	
69. Status <input type="checkbox"/> Left <input type="checkbox"/> Impound <input type="checkbox"/> Stored		70. Registered Owner				71. R.O. Address					
72. Towed to or Released to				73. Who has Keys?							
74. Evid <input checked="" type="checkbox"/> Yes <input type="checkbox"/> No		75. F / P <input checked="" type="checkbox"/> Yes <input type="checkbox"/> No		76. Dispo of Evidence Delta Station Evidence Room			77. Missing none		78. Damaged \$250 (est)		
79. Brief Synopsis of Incident This report concerns an unknown suspect(s) shattering a rear window at the Discovery Bay Community Center building. This report is suspended pending latent print processing by crime lab.											
<p>CONTROLLED DOCUMENT Office of the Sheriff Contra Costa County</p> <p>SEP 13 2013</p> 											
In-car Video <input type="checkbox"/> Yes <input checked="" type="checkbox"/> No											
MARSYS LAW <input checked="" type="checkbox"/> Yes <input type="checkbox"/> No				ELDER ABUSE FORM SOC 341 <input type="checkbox"/> Yes <input checked="" type="checkbox"/> No				VICTIM RESPONSE - 293 PC <input type="checkbox"/> Yes <input checked="" type="checkbox"/> No			
80. Distribution <input type="checkbox"/> B <input type="checkbox"/> C <input type="checkbox"/> DA <input type="checkbox"/> DE <input type="checkbox"/> L <input type="checkbox"/> O <input type="checkbox"/> MOTCO <input type="checkbox"/> Investigation <input type="checkbox"/> MP <input type="checkbox"/> HSU/APT <input type="checkbox"/> V <input type="checkbox"/> Coroner <input type="checkbox"/> Property Ck. <input type="checkbox"/> Patrol Clerk <input type="checkbox"/> R.O. <input type="checkbox"/> SHC <input type="checkbox"/> Patrol Captain <input type="checkbox"/> Misd.Comp. <input checked="" type="checkbox"/> Crime Analysis <input type="checkbox"/> OAK						81. Additional Routing Discovery Bay Resident Deputies					
82. Reporting Deputy (Print) Mark Spaulding						83. Date/Time Written 08/28/2013 / 1000		84. Dispo SUS			
85. Approving Supv (Print) David Cook						86. Supv No. 60154		87. Date 08/28/2013			

Continuation

OFFICE OF THE SHERIFF, CONTRA COSTA COUNTY CA0070000

Beat 32

Supplemental

P.O. Box 391, Martinez, CA 94553-0039

D.V. HRO Arrest SI

1. DR No. 13-15083	2. City Code DEL	3. Crime / Classification VANDALISM MISDEMEANOR	4. Detail 1. 694M 2.	5. Reclassification <input type="checkbox"/>
6. Victim Name (L,F,M) Discovery Bay		Type: <input type="radio"/> Business <input checked="" type="radio"/> Individual <input type="radio"/> Government Town of	7. Date Orig. Report 08/28/2013	8. Employee No. 61600
9. Address / Location of Occurrence 1601 Discovery Bay Blvd		City Discovery Bay	State CA	Zip 94505
10. Suspect's Name (L,F,M)		Type: <input type="radio"/> Business <input checked="" type="radio"/> Individual <input type="radio"/> Government		

11. Property Description: Impounded, Recovered, Found, Lost, Stolen - Item Number, Article, Quantity, Brand/Make/Manufacturer's Model Number, Serial Number, Miscellaneous Description, Location Where Taken, Value, Include Total Loss - LIST IN FOLLOWING ORDER: A) Currency, Notes; B) Jewelry; C) Cars; D) Vehicles; E) Office Equipment; F) Radio, TVs, etc.; G) Firearms; H) Household Goods; I) Misc.

12. Recovered Property \$

13. Narrative / Statements

On 8/28/13, I responded to 1601 Discovery Bay Blvd. and spoke with PR-Esteven Rocha. Rocha showed me a rear window that had been shattered. Rocha told me the window was not broken yesterday (8/27/13) when the building was closed for the night. This morning (8/28/13) when Rocha arrived, and unlocked the building he found the window broken. When Rocha found the window the window was in the open position, as if someone had opened it to enter the building. Rocha has checked the interior and there is no signs of anyone making entry into the building. Rocha estimated the value of the window at \$250.

I was unable to locate what was used to break the window. I processed the window for latent prints and recovered three print cards from the exterior of the window. The print cards will be logged into the Delta Station evidence room to be sent to the Crime Lab for processing.

This report is suspended pending the results of the latent print cards.

DAMAGE:

1) one window

EVIDENCE:

1) three latent print cards

CONTROLLED DOCUMENT
Office of the Sheriff
Contra Costa County

SEP 13 2013

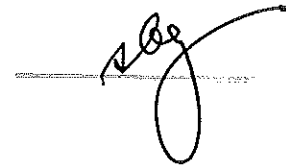

14. Distribution

B C DA DE L O MOTCO

Investigation MP HSU/APT V Coroner

Property Ck. Patrol Clerk R.O. SHC

Patrol Captain Misd. Comp. Crime Analysis OAK

15. Additional Routing
Discovery Bay Resident Deputies

16. Reporting Deputy (Print) Mark Spaulding	17. Date/Time Written 08/28/2013 / 1000	18. Dispo SUS
19. Approving Supv (Print) David Cook	20. Supv No. 60154	21. Date 08/28/2013

Face Page
 Continuation
 Supplemental

OFFICE OF THE SHERIFF, CONTRA COSTA COUNTY CA0070000
P.O. Box 391, Martinez, California 94553-0039

Beat 32

D.V. HRO Arrest SI

1. DR No. 13-15227		2. City Code DEL		3. Crime/Classification VANDALISM MISDEMEANOR			4. Detail 1. 594M 2.		5. More Persons <input type="checkbox"/>		
6. Day / Date / Time of Occurrence From THU 08/29/2013 1930 To FRI 08/30/2013 1036					7. Date / Time Reported 08/30/2013 / 1041		8. Employee No. 66581		9. Reclassification <input type="checkbox"/>		
10. Address / Location of Occurrence 1601 Discovery Bay Boulevard						City Discovery Bay		State Ca	Zip 94505		
11. <input checked="" type="checkbox"/> PRI <input type="checkbox"/> VIC <input type="checkbox"/> WIT <input type="checkbox"/> MSP <input type="checkbox"/> RUN <input type="checkbox"/> SUS <input type="checkbox"/> LEAD <input type="checkbox"/> OTHER											
12. Name (L, F, M) Zamora			Type: <input type="checkbox"/> Business <input checked="" type="checkbox"/> Individual <input type="checkbox"/> Government Cynthia Lu			13. Race / Sex / Age W / F		14. DOB		15. Driver License No/State	
16. Address Street						City		State	Zip		
17. Home Phone						19. Work Phone					
20. Hair RED		21. Eyes GRN	22. Ht. 505	23. Wt. 135	24. AKA / Maiden Name			Email Address		25. Social Security No.	
26. Further Description (Scars, Tattoos, Mannerisms, Clothing, Etc.)							Cell Phone		27. Booking or Cite No.		
28. <input type="checkbox"/> PRI <input checked="" type="checkbox"/> VIC <input type="checkbox"/> WIT <input type="checkbox"/> MSP <input type="checkbox"/> RUN <input type="checkbox"/> SUS <input type="checkbox"/> LEAD <input type="checkbox"/> OTHER											
29. Name (L, F, M) Town of Discovery			Type: <input type="checkbox"/> Business <input checked="" type="checkbox"/> Individual <input type="checkbox"/> Government Bay			30. Race / Sex / Age		31. DOB		32. Driver License No/State	
33. Address Street 1601 Discovery Bay Boulevard						City Discovery Bay		State Ca	Zip 94505	34. Home Phone (925) 634-1131	
35. Employed By or School						38. Work Phone					
37. Hair		38. Eyes	39. Ht.	40. Wt.	41. AKA / Maiden Name			Email Address		42. Social Security No.	
43. Further Description (Scars, Tattoos, Mannerisms, Clothing, Etc.)							Cell Phone		44. Booking or Cite No.		
45. <input type="checkbox"/> PRI <input type="checkbox"/> VIC <input type="checkbox"/> WIT <input type="checkbox"/> MSP <input type="checkbox"/> RUN <input type="checkbox"/> SUS <input type="checkbox"/> LEAD <input type="checkbox"/> OTHER											
46. Name (L, F, M)			Type: <input type="checkbox"/> Business <input checked="" type="checkbox"/> Individual <input type="checkbox"/> Government			47. Race / Sex / Age		48. DOB		49. Driver License No/State	
50. Address Street						City		State	Zip	51. Home Phone	
52. Employed By or School						53. Work Phone					
54. Hair		55. Eyes	56. Ht.	57. Wt.	58. AKA / Maiden Name			Email Address		59. Social Security No.	
60. Further Description (Scars, Tattoos, Mannerisms, Clothing, Etc.)							Cell Phone		61. Booking or Cite No.		
62. Veh / Yes <input type="checkbox"/> S <input type="checkbox"/> Vict		63. Lic No. (State)		64. Year	65. Make		66. Model	67. Body Style	68. Color Top Bottom		
69. Status <input type="checkbox"/> Left <input type="checkbox"/> Impound <input type="checkbox"/> Stored		70. Registered Owner			71. R.O. Address						
		72. Towed to or Released to				73. Who has Keys?					
74. Evid <input checked="" type="checkbox"/> Yes <input type="checkbox"/> No		75. F / P <input type="checkbox"/> Yes <input checked="" type="checkbox"/> No		76. Dispo of Evidence Photos attached to report			77. Missing N/A		78. Damaged \$250		
79. Brief Synopsis of Incident This report concerns unknown suspect(s), breaking a concession stand window at the Discovery Bay community center with an unknown object. PRI-Zamora walked through the community center, but did not see anything missing or disturbed. Several blood stains were discovered on the walkway near the concession stand. CSI Crain responded and processed the scene for evidence. (Refer to CSI Crain's report for further information). Zamora does not know who could have vandalized the concession stand window. I canvassed the area for possible leads or witnesses with negative results. There are no suspects, leads, or witnesses at this time.											
Evidence: 1. Four photos from the scene											
<p>CONTROLLED DOCUMENT Office of the Sheriff Contra Costa County</p> <p>SEP 13 2013</p> <p><i>[Signature]</i></p>											
In-car video <input type="checkbox"/> Yes <input checked="" type="checkbox"/> No											
MARSY'S LAW <input checked="" type="checkbox"/> Yes <input type="checkbox"/> No			ELDER ABUSE FORM SOC 341 <input type="checkbox"/> Yes <input checked="" type="checkbox"/> No				VICTIM RESPONSE - 293 PC <input type="checkbox"/> Yes <input checked="" type="checkbox"/> No				
80. Distribution <input type="checkbox"/> B <input type="checkbox"/> C <input type="checkbox"/> DA <input type="checkbox"/> DE <input type="checkbox"/> L <input type="checkbox"/> O <input type="checkbox"/> MOYCO <input type="checkbox"/> Investigation <input type="checkbox"/> MP <input type="checkbox"/> HSU/PT <input type="checkbox"/> V <input type="checkbox"/> Coroner <input type="checkbox"/> Property Ck. <input type="checkbox"/> Patrol Clerk <input type="checkbox"/> R.O. <input type="checkbox"/> SHC <input type="checkbox"/> Patrol Captain <input checked="" type="checkbox"/> Misd.Comp. <input type="checkbox"/> Crime Analysis <input type="checkbox"/> OAK						81. Additional Routing					
						82. Reporting Deputy (Print) Erik Steele		83. Date/Time Written 08/30/2013 / 1145		84. Dispo SUS	
						85. Approving Supv (Print) Saritla Ellison		86. Supv No. 62495	87. Date 08/31/2013		

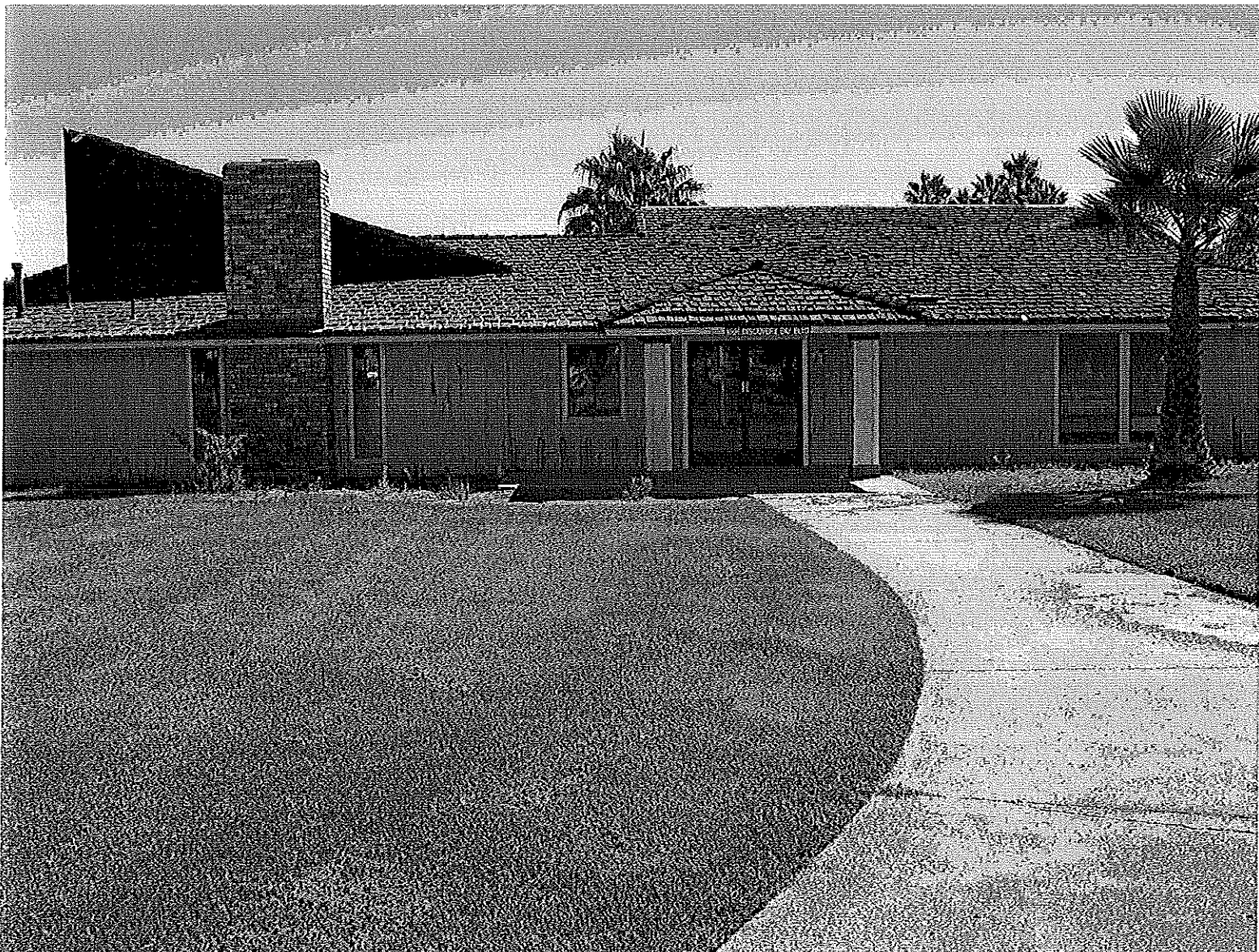

CONTROLLED DOCUMENT
Office of the Sheriff
Contra Costa County

SEP 13 2013





CONTROLLED DOCUMENT
Office of the Auditor
Contra Costa County

SEP 13 2013

roy



CONTROLLED DOCUMENT
Office of the Sheriff
Contra Costa County

SEP 13 2013

[Handwritten signature]



CONTROLLED DOCUMENT
Office of the Sheriff
Contra Costa County

SEP 13 2013

[Handwritten signature]



eQuote
eQuote Number: 240

Payment Terms:
Expiration Date:12/30/2013

Quote Prepared For

Gregory Harris
Town of Discovery Bay

United States
Phone:925-634-1131
gharris@herwit.com

Quote Prepared By

Mario Campos
QPCS
1141 Kansas Avenue
Modesto, CA 95351
United States
Phone:888-410-4240
Fax:775-244-6394
mcampos@qpcs.net

ITEM#	QUANTITY	ITEM NAME	UNIT PRICE	UNIT DISCOUNT	ADJUSTED UNIT PRICE	EXTENDED PRICE
One-Time Items						
1)	3	VideoIQ - iCVR Indoor/Outdoor full HD 1080p dome with 500GB onboard storage, 3-8mm lens - Solid Stat -Up to 90 Days Recording Storage -Adaptive Video Analytics -High-End Video Capture - 3Megapixel -Including Licensing for Mobile Apps (IOS/Android) and desktop -24/7 Recording to Solid State HDD -VideoIQ Enclosure meets IP65 standards - 2 year manufactures warranty	\$2,158.00	\$0.00	\$2,158.00	\$6,474.00
2)	3	VIQ-DCM1 iCVR™ Dome Pendant Ceiling Mount Bracket (requires VIQ-DPC2)	\$98.00	\$0.00	\$98.00	\$294.00
3)	3	VIQ-DPC1 iCVR™ Dome Pendant Cap, 3.6mm outer wall, 3mm inner wall, aluminum (requires VIQ-DPWM1)	\$190.19	\$0.00	\$190.19	\$570.57
4)	3	VIQ-DPWM1 iCVR™ Wall Mount Arm (requires VIQ-DPC2)	\$69.00	\$0.00	\$69.00	\$207.00
5)	1	Network POE 16-Port 10/100Mbps PoE Switch - 16x Ports, PoE, 3.2Gbps switching capacity Network POE Switch with 16ports for POE connection to Cameras, Phones, etc	\$369.00	\$0.00	\$369.00	\$369.00
6)	10	Technical Labor - Prevailing Wage Installation of camera equipment on wall. Setup of camera, configuration of field-of-view, setup of alarms.	\$95.00	\$0.00	\$95.00	\$950.00
One-Time SubTotal						\$8,864.57
Total Taxes						\$598.76
One-TimeTotal						\$9,463.33

Comment: Network Cabling by Town of Discovery Bay

Total **\$9,463.33**

Optional Items

ITEM#	QUANTITY	ITEM NAME	UNIT PRICE	UNIT DISCOUNT	ADJUSTED UNIT PRICE	EXTENDED PRICE
7)	1	Loudspeaker System - 15Watt Speaker for RSU Loudspeaker System Kit includes additional Power Supply, RCA/Audio Connections, wiring, etc	\$500.00	\$50.00	\$450.00	\$450.00
8)	1	ViewPoint Monitoring Monthly Remote Monitoring (Reoccurring Monthly Charge) Services by ViewPoint -handle video analytics alarms -Includes 25 events/month	\$198.00	\$0.00	\$198.00	\$198.00
9)	1	Yearly Maintenance Agreement Reoccurring Annual Fee -Tech Support -Firmware Updates -Annual On-site Cleaning and Inspection -Temporary Replacement Camera During Repair	\$1,325.00	\$0.00	\$1,325.00	\$1,325.00
10)	3	Extended Warranty 3 Year Manufactures Extended Warranty	\$1,710.50	\$0.00	\$1,710.50	\$5,131.50
Optional SubTotal						\$7,104.50
Total Taxes						\$39.38
OptionalTotal						\$7,143.88
Including Optional Quote Items						
Total						\$16,607.21

Authorizing Signature _____

Date _____

Interest Charges on Past Due Accounts and Collection Costs Overdue amounts shall be subject to a monthly finance charge. In addition, customer shall reimburse all costs and expenses for attorney's fees incurred in collecting any amounts past due. Additional training or Professional Services can be provided at our standard rates.



VIDEOIQ®



VideolQ® iCVR-HD IP Camera

The only true megapixel analytics device

VideolQ is the first and only company to deliver true real-time megapixel analytics in an all-in-one device. This means every VideolQ video surveillance system delivers high definition video along with the industry's most reliable and accurate analytics and onboard distributed NVR storage. The feature rich iCVR HD camera is easy to install because of the continuously self-calibrating analytics and can be deployed over low bandwidth networks, eliminating the need for high-capacity networks. The iCVR HD camera and VideolQ architecture is designed to address the most challenging security needs in the most difficult of environments. It is the right choice for pro-active, intelligent video surveillance.

iCVR-HD Quick Facts

- ▶ 1080p/30fps video provides 7x the resolution of a standard VGA camera.
- ▶ Embedded, adaptive analytics for real-time threat detection and forensic evidence.
- ▶ Free VideolQ View™ software offers IQTrack™ which tracks and zooms-in automatically
- ▶ On-board distributed storage eliminates continuous streaming to central servers.
- ▶ Simple, user configurable rules-based alerts can be sent to multiple VMS users and emails simultaneously.
- ▶ Continuously self-calibrating analytics reduce install time and false positive alarms.
- ▶ Scalable and pro-active intelligence in one device.

Key Features

The industry's ONLY high definition analytics. 1080p/30fps video provides dramatic clarity, range and accuracy. When combined with VideolQ's award-winning adaptive analytics, which are based on pattern analysis rather than pixel analysis, they become more accurate, reducing false positive alarms. This allows security personnel to focus only on events of high interest.

On-board storage eliminates costly infrastructure. Unlike conventional megapixel cameras, the iCVR-HD cameras uniquely store full 1080p video in up to 750 GB of onboard NVR storage. This eliminates the need to continuously stream video to central storage — reducing network traffic and bandwidth consumption by over 90%. As a result, the iCVR-HD can be deployed in any environment, including mixed IT networks, wireless networks, and WAN deployments.

Easy to install and use. Continuously self-calibrating analytics adapt to the installed environment, eliminating manual programming and reducing installation and maintenance costs. Free VideolQ View™ software further simplifies operation for end-users and integrators. And the system is widely integrated with leading 3rd party VMS providers.

Effortlessly scales megapixel video in any deployment. As an all-in-one device, the iCVR-HD camera can gracefully scale from 1 to 1000+ cameras without re-engineering the network. Storage requirements and streaming are automatically managed to control bandwidth usage, making it easy to add cameras without requiring additional infrastructure or compromising analytic or forensic quality.

Enhanced Features

Two-way Audio	Live audio interaction is a proven method to reduce theft and vandalism. Provides real-time response to threats.
Alarm I/O	Interact with other hardware devices or sensors.
Motorized Lens	Allows for remote fine-tuning of field of view improving accuracy and minimizing maintenance.
Multiple Power Options	PoE, 12VAC, 24VAC. PoE can be combined with 12 or 24V for redundancy.
IP66 Enclosure	Ready to go for indoor or outdoor environments
On-board NVR storage	Reduces bandwidth usage, offers robust standalone storage and enables linear scalability. Up to 750GB available.

iCVR-HD Fixed Dome Camera — Specifications

High Definition Dome Camera Models

- VIQ-HD-CRD225-3-8 — Day/night, 250 GB hard drive, 3-8mm lens
- VIQ-HD-CRD250-3-8 — Day/night, 500 GB hard drive, 3-8mm lens
- VIQ-HD-CRD232-3-8-MF — Day/night, 320 GB hard drive, motorized focus, 3-8mm lens
- VIQ-HD-CRD275-3-8-MF — Day/night, 750 GB hard drive, motorized focus, 3-8mm lens
- Available as Low Temp models (-LT)

Camera Specifications

- Wide dynamic range 1080p CMOS image sensor
- Mechanical Day/Night Filter
- 1920 X 1080 pixels (1080p)
- Dynamic Range: 70dB (typical)
- Sensitivity 0.25 lux at F1.2
- Signal to Noise greater than 50db
- Auto iris and white balance control
- Analog output: NTSC or PAL via BNC connector

Storage Specifications

- Internal storage: 2 GB solid state memory in all models
- All hard drives include patent pending hard drive lifespan extension technology: increases life expectancy of hard drive to 10+ years
- Typical storage use: 250 GB per month

Video Specifications

- H.264 compression, Main, Baseline or High Profile
- MJPG Stream for mobile/web viewing
- Recording up to 30fps in Alarm Recording, 15fps in non-Alarm
- Dual Stream Encoding: Independent control of viewing and recording stream, from selected settings

Alarm and Audio Inputs and Outputs

- RCA Audio I/O jack
- Audio compression: G.711
- Audio streaming live two-way: full duplex
- Audio recording — alarm or continuous
- Two alarm inputs — TTL
- Alarm output — Optical relay, 20mA max., programmable normally open or normally closed

Networking and Communications

- Ethernet 10/100 BaseT—RJ45 connector
- ZeroConf auto IP discovery of cameras
- Security: Multiple user access levels with password protection, IP address filtering, and HTTPS encryption
- Web browser access to camera via built-in web server

Self-Calibrating High Definition Video Analytics

- Powerful VideoIQ self-calibrating analytic engine with rich library of behaviors
 - Fence-line and Perimeter Crossing Detection
 - Area Protection
 - Direction of Travel Alerts
 - Crowd Detection
 - Loitering and Dwell Time Alarms
 - Missing Object Detection
 - Cross Camera Object Search
- Automatic alarm reporting with video verification clip
- Fully automated calibration and tuning: delivering the highest level of accuracy while reducing installation time and maintenance

Power

Standard Cameras:

- PoE Class 3, 12VDC, 24VAC
 - 10 watts max power, 7 watts typical
- #### Low Temp Models (when below 15°F):
- 42W max power, 32W typical
 - Low-temp cameras require 12VDC or 24VAC power

Environmental

- Operating Temp: -20°C to 50°C (-4°F to 122°F)
- Low Temp models: -30°C to 50°C (-22°F to 122°F)
- Storage Temp: -30°C to 70°C (-22°F to 158°F)
- Humidity: 20-80% RH (non-condensing)
- Heater and blower built in

Diagnostics

- Loss of communications trouble alert
- Hard drive failure alert
- Scene change trouble alert

Warranty

- 2-years, parts and repair labor

Dimension and Weight

- Camera Dimensions: 6.3" outer diameter x 8.19" tall (with surface mount kit) (16.00 cm outer diameter x 20.8 cm tall)
- Weight: 4.2 pounds (1.9 kg)

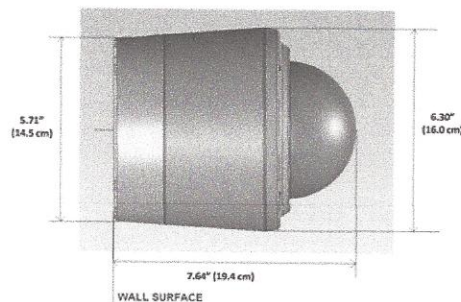
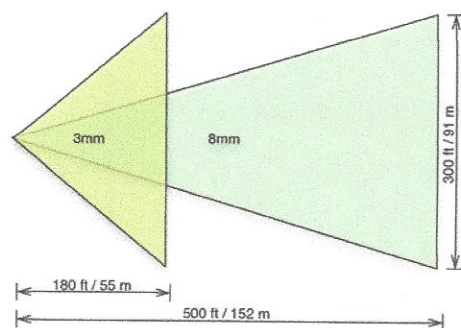

Illustration of Dimensions



iCVR HD 1080p 2.1 Megapixel Camera
Typical Coverage Charts (Overhead View)

- Typical FOV width: 300 feet / 91 meters



VideoIQ, Inc.
213 Burlington Road
Bedford, MA 01730

1-888-351-1758
1-781-222-3069

info@videoiq.com
www.videoiq.com

© 2012 VideoIQ, Inc. All rights reserved.



P.O. Box 5208
1309 Pine Street
Walnut Creek, CA
94596

Tel: 925-932-2211
Fax: 925-935-2323

CCTV QUOTATION

9-16-13

**Sue Heintl
Town of Discovery Bay**

Project: CCTV SYSTEM for the Pool Area

Scope of Work

Denalect Alarm is pleased to submit for your review our proposal in the amount of **(\$6499.00) for the CCTV system.**

With audio (\$8499)

This Quote is for the installation of a camera system at the Gym @ 1601 Discovery Bay Blvd

This price includes schedule of equipment below, wiring of equipment below, installation and connection of devices below. 1 Year warranty parts and labor.
Final testing and instruction on use of system.

EQUIPMENT LIST

- 1 - 4- channel NVR with internet ability
- 1 - Out door IP 3mp camera to view the front parking area.
- 1 - Out door IP 3MP camera to view the pool area
- 1 - Outdoor IP 3 MP camera to view the south side area
- 1 - Programming, Test, Check and end user training
- 1 - Lot Wire, connectors & fasteners

PROVIDED AND INSTALLED BY ELECTRICAL

Electrical outlet for power at the NVR location

Please give me a call and let me know how you would like to proceed or if you have any questions. Our telephone number is 925-932-2211.

Sincerely,

Stefan Burdt

Operations Manager

24 Hour Service

Burglar, Fire, Holdup,
CCTV and Card
Access Systems.

Alarm Lic. ACO255
Contractors Lic. 382961



Underwriter
Laboratories listed

ICIP-3000DV-IR



ICIP-3000DV-IR: 3.0 Mega Pixel 65ft IR Vandal Dome with SD Storage 4.5-10MM POE

- 1/2.8" 3.0 Megapixel SONY progressive scan Exmor CMOS image sensor
- High-performance TI DaVinci series DSP
- H.264 video compression and JPEG image capture
- 15fps at 3.0M(2048×1536) and 25/30fps at 1080P resolution
- Dual encoding streams supported
- Support ICR true Day/Night
- Built-in 4.5~10mm/F1.6 CS Auto Iris lens
- Built-in high-performance IR LEDs(10~20m)
- Support Alarm I/O, RS485 interface
- Support up to 32GB Micro SD card for local storage
- Support DC12V/AC24V dual power supply, POE
- IK10-rated Vandal-proof & IP66 Water-proof
- Built-in web server, NVR, DMSS & CMS

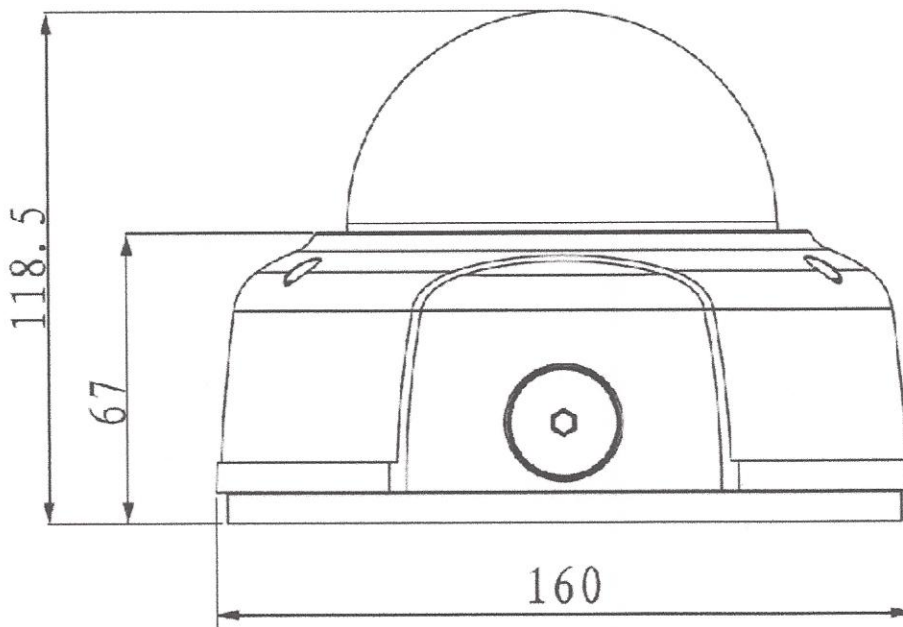
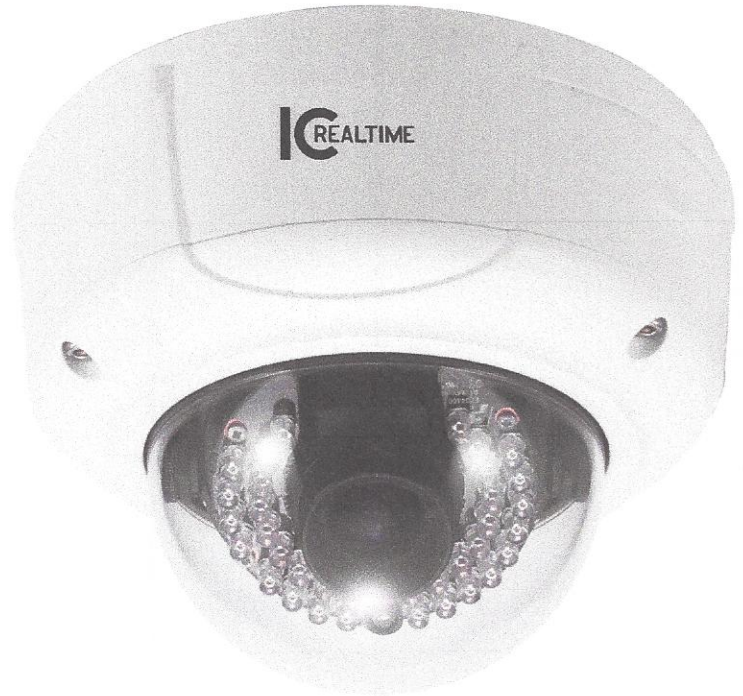

Head Office

IC Realtime
3050 N Andrews Ave EXT
Pompano Beach,
FL 33064

T 1 866 997 9009
F 1 954 827 5900
E info@icrealtime.com
W www.icrealtime.com

West Coast Office

IC Realtime
14200 W. Van Buren st Suite C-106
Goodyear,
AZ 85338

T 1 602 910 3432
F 1 602 626 3545
E west@icrealtime.com
W www.icrealtime.com



Model	ICIP-3000DV-IR	
General		
Processor	TI DaVinci Series DSP	
Operating System	Embedded LINUX	
Resource	Simultaneous remote monitoring, local recording and remote control	
User Interface	WEB, CMS(DSS, PSS)	
Camera		
Image Sensor	1/2.8" 3.0 Megapixel SONY progressive scan Exmor CMOS	
Effective Pixels	2096(H)×1561(V)	
Electronic Shutter	Auto/Manual, 1/60~1/10000s	
Mini. Illumination	0.2LUX/F1.6(Color), 0.01LUX/F1.6(B/W), 0LUX(IR on)	
Signal Noise Ratio	>50dB	
Gain Control	Auto/Manual	
White Balance	Auto/Manual	
Day/Night	ICR	
Lens	CS mount, Auto Iris, 4.5~10mm /F1.6	
IR LEDs	10~20 meters	
Video		
Video Compression	H.264/JPEG	
Image Resolution	3.0M(2048×1536) / 1080P(1920×1080) / 720P(1280×720) / D1(704×480) / CIF(352×240) / VGA(640×480)	
Encoding Speed	Main Stream: 3.0M(1~15fps), 1080P/720P/ D1/CIF/ VGA(1~30fps)	
	Extra Stream: D1/CIF (1~25fps)	Extra Stream: D1/CIF (1~30fps)
Bit Rate	160K~8Mbps	
Snapshot	Fastest 1fps JPEG capture	
Video Format	NTSC	
Analogue Video Output	1 channel BNC(1.0Vp-p, 75?)	
Audio		
Audio Compression	G.711a / G.711u / PCM	
Bit Rate	64kbps/128kbps	
Input	1 channel RCA	
Output	1 channel RCA	
Network		
Ethernet	RJ-45 (10/100Base-T)	
Network Functions	HTTP, TCP/IP, ICMP, RTSP, RTP, UDP, SMTP, NTP, DHCP, DNS, IP Filter, PPPOE, DDNS, FTP, Alarm Server	
Remote Operation	Monitor, PTZ control, Playback, System setting, File download, Log information, Maintenance & Upgrade	
Auxiliary Interface		
MicroSD Card	Max 32GB, local storage	
RS485	OSD control	
Alarm	2 Input / 1 Output	
Environmental		
Power Supply	DC12V/AC24V, PoE	
Power Consumption	<10W	
Ingress Protection	IK10 & IP66	
Operating Environment	-10°C~+60°C, 10%~90%	
Dimension	Φ160mm×118.5mm	
Weight	1.25kg	

Head Office

IC Realtime
 3050 N Andrews Ave EXT
 Pompano Beach,
 FL 33064

T 1 866 997 9009
 F 1 954 827 5900
 E info@icrealtime.com
 W www.icrealtime.com

West Coast Office

IC Realtime
 14200 W. Van Buren st Suite C-106
 Goodyear,
 AZ 85338

T 1 602 910 3432
 F 1 602 626 3545
 E west@icrealtime.com
 W www.icrealtime.com

FLEXIDOME starlight HD 720p60 VR

www.boschsecurity.com



BOSCH

Invented for life



HD Onvif



- ▶ Excellent low-light performance (0.017 lx in color)
- ▶ Content-based scene analysis optimizes the image processing
- ▶ Intelligent noise reduction reduces bandwidth and storage requirements by up to 30%
- ▶ Aesthetic vandal-resistant enclosure, suitable for indoor or outdoor applications
- ▶ Easy to install with auto zoom/focus SR lens, wizard and pre-configured modes

The FLEXIDOME starlight HD 720p60 VR camera provides clear images 24/7 – even at night or under low-light conditions.

High sensitivity in color (0.017 lx) and monochrome mode (0.0057 lx) enables this camera to work with a minimum of ambient light. This exceptional light sensitivity combined with Content-Based Imaging Technology (C-BIT) ensures crisp, clear, and detailed images in all lighting conditions. The 720p HD can also provide up to 60 images per second.

The aesthetic vandal resistant housing makes the camera suitable for indoor or outdoor installation.

System overview

Compared to SD cameras, the FLEXIDOME HD 720p60 offers, at no higher cost, motorized autofocus, higher resolution, better sensitivity, higher frame rates, and improved picture quality, and is still more bandwidth-efficient. Video storage costs are significantly reduced.

Functions

Exceptional low-light performance

The latest sensor technology combined with the sophisticated noise suppression results in a sensitivity of 0.017 lx in color. The low-light performance is so

good that the camera continues to provide excellent color performance even with a minimum of ambient light.

The camera is a true day/night camera with a mechanical filter for truly outstanding nighttime performance (0.0057 lx in monochrome). The filter can be switched remotely, or automatically via a light level sensor or contact input.

Content-based Imaging Technology

Content-Based Image Technology (C-BIT) is used to radically improve image quality in all lighting conditions and to identify areas for enhanced processing. The camera examines the scene using intelligent video analytics and provides feedback to re-tune the image processing. This provides better detail in the areas that matter and better all-round performance. In IVA versions, the intelligent Automatic Exposure (iAE) technology, for example, allows you to view moving objects in bright and dark areas of a scene.

Low bandwidth consumption

The intelligent Dynamic Noise Reduction (iDNR) actively analyzes the contents of the scene to reduce bandwidth and storage requirements. This removes noise artifacts so effectively that compression

efficiency is very high (up to 30% improvement). This results in reduced-bandwidth streams that still retain a high image quality and smooth motion. The camera provides the most usable image possible by cleverly optimizing the detail-to-bandwidth ratio via temporal and spatial noise filtering.

Area-based encoding reduces unnecessary bandwidth. Compression parameters for up to eight user-definable regions can be set. This allows uninteresting regions to be highly compressed, thus lowering bandwidth consumption and storage requirements. Important regions can be tuned for best image quality, thus allowing the user to allocate bandwidth to important parts of the scene.

Fast performance

The 60 images-per-second mode provides for optimum performance in fast action scenes and is particularly suitable for casino and banking applications.

Flexible lens choice

The camera comes with a choice of AVF (Automatic Varifocal) lenses for easy installation. These SR (Super Resolution) lenses have an advanced iris design to ensure that the high resolution HD sensor produces the sharpest image possible, even in the corners.

Simple installation

The camera has a very intuitive user interface that allows fast and easy configuration. Six configurable user modes are provided with the best settings for a variety of applications:

- **Indoor** – general day-to-night changes without sun highlights and street lighting
- **Outdoor** – general day-to-night changes with sun highlights and street lighting
- **Motion** – monitoring traffic or fast moving objects; motion artifacts are minimized
- **Lowlight** – optimized for sufficient details at low light.
- **Intelligent AE** (BLC on non-IVA models) – for people moving in front of a bright background
- **Vibrant** – enhanced contrast, sharpness and saturation

The automatic zoom/focus lens wizard makes it easy for an installer to accurately zoom and focus the camera for both day and night operation. The wizard is activated from the PC or from the on-board camera push button making it easy to choose the workflow that suits best.

The AVF (Automatic Varifocal) feature means that the zoom can be changed without opening the camera. The automatic motorized zoom/focus adjustment with 1:1 pixel mapping ensures the camera is always accurately focused.

Streams

The innovative multi-streaming feature delivers various H.264 streams together with an M-JPEG stream. These streams facilitate bandwidth-efficient viewing and recording as well as integration with third-party video management systems.

An upright mode can be selected for the second stream. In this mode an image of 400 x 720 (9:16 aspect ratio) is cropped from the full sensor image. When the scene to be monitored is suitable to this mode, the bandwidth and storage requirements are reduced.

Storage management

A microSD card can be used for local alarm recording or for Automatic Network Replenishment (ANR) to improve the overall recording reliability. Recording management can be controlled by the Bosch Video Recording Manager (VRM) or the camera can use iSCSI targets directly without any recording software.

Intelligent Video Analytics

IVA versions of the camera use the latest generation of the Bosch Intelligent Video Analysis (IVA) software. This IVA system is the guard-assistant system of choice when reliable indoor or outdoor video analytics is needed. The state-of-the-art system reliably detects, tracks, and analyzes moving objects while suppressing unwanted alarms from spurious sources in the image. The face detection feature detects faces in the scene and forwards a high quality JPEG image of the best shot of each face when the face disappears from the scene.

Retrospective forensic search capabilities are available remotely from the web browser or the Bosch Video Client.

Regions of interest

Two Regions of Interest (ROI) can be user defined. The remote electronic pan, tilt and zoom controls allow you to select specific areas of the parent image. These regions produce separate streams for remote viewing and recording. These streams, together with the main stream, allow the operator to separately monitor the most interesting part of a scene while still retaining situational awareness.

The IVA Intelligent tracker can also follow objects within the defined regions of interest. The Intelligent tracker can autonomously detect and track moving objects or the user can click on an object which the Intelligent tracker will then follow.

Aesthetic vandal resistant design

Ideal for indoor or outdoor use, the compact aesthetic design is suitable for installations where housing size and appearance are very important. The cast-aluminum housing, polycarbonate window, and hardened inner liner can withstand the equivalent of 55 kg (120 lbs) of force (IK10). The camera is protected against water and dust to IP 66 (NEMA Type 4X) standards. Using the proprietary pan/tilt/rotation mechanism, installers can select the exact field of view. Mounting options are numerous, including surface, wall, corner, and suspended-ceiling mounting.

Access Security

Password protection with three levels and 802.1x authentication is supported. To secure Web browser access, use HTTPS with a SSL certificate stored in the camera. The video and audio communication channels can be independently AES encrypted with 128-bit keys by installing the optional encryption site license.

Surveillance software

There are many ways to access the camera’s video and IVA-based features: using a web browser, with the Bosch Video Management System, with the Bosch Recording System, with the free-of-charge Bosch Video Client, or with the iPad App.

The Bosch Video Client PC surveillance software offers a user-friendly interface to support easy installation and configuration. It also provides easy live viewing of multiple cameras, playback, forensic search and export.

Access to IVA metadata is available to integrators via RTSP.

Video security App

The Bosch Video Security iPad App has been developed to fully utilize our Dynamic Transcoding features and enable **Anywhere** access to HD surveillance images, even over low-bandwidth connections. The App, together with the Bosch transcoder, is configured to give you complete control of all your cameras, from panning and tilting to zoom and focus functions. It’s like taking your control room with you.

Hybrid mode

An analog video output enables the camera to operate in hybrid mode. This mode provides simultaneous high resolution HD video streaming and an analog video output via a BNC connector. The hybrid functionality offers an easy migration path from legacy CCTV to a modern IP-based system.

Connections

The camera conforms to the ONVIF (Open Network Video Interface Forum) Profile S specification. This guarantees interoperability between network video products regardless of manufacturer. For trouble-free network cabling, the camera supports Auto-MDIX which allows the use of straight or cross-over cables. Camera power is supplied via PoE (Power-over-Ethernet) or via the 24 VAC/12 VDC connector. Third-party integrators can easily access the internal feature set of the camera for integration into large projects. Visit the Bosch Technology Partner Program (TPP) website (tpp.boschsecurity.com) for more information.

- Aspect ratio: 16:9
- Frame rate: 25/30 and 50/60 frames/s

Electro Magnetic Compatibility

Emission	EN 55022 Class B FCC Part 15 Class B
Immunity	EN 50130-4 (PoE, +12 VDC, 24 VAC)* EN 50121-4
Safety	EN 60950-1 UL 60950-1 (2nd edition) CAN/CSA-C 22.2 No. 60950-1
Vibration	Camera with lens as per IEC 60068-2-6 (5 m/s ² , operational)

* Chapters 7 and 8 (mains voltage supply requirement) are not applicable to the camera. However, if the system in which this camera is used needs to comply with this standard, then any power supplies used must comply with this standard.

Region	Certification
Europe	CE
USA	UL
	FCC

Installation/configuration notes

Dimensions flush mounting

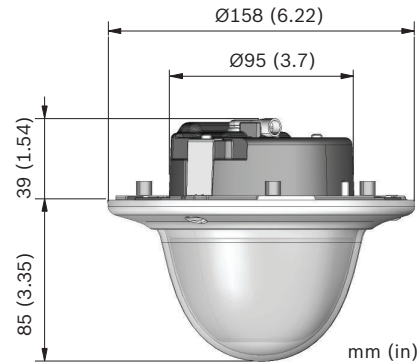

Dimensions surface mounting

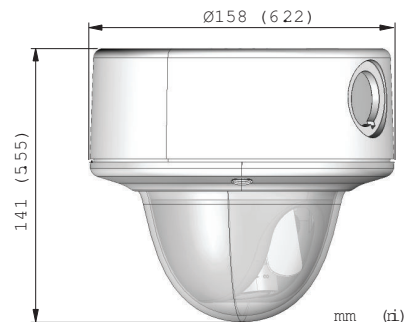

Certifications and approvals

HD Standards

Complies with the 296M-2001 Standard in:

- Resolution: 1280x720
- Scan: Progressive
- Color representation: complies with ITU-R BT.709

Brackets (not included)

VDA-WMT-DOME –Pendant Wall Mount

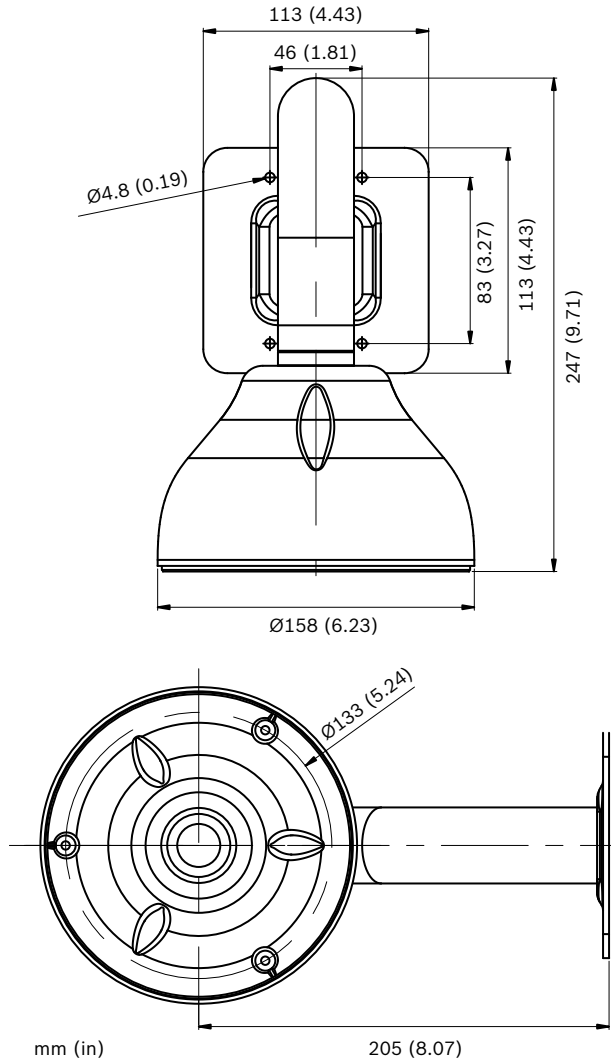

VDA-PMT-DOME –Pendant Pipe Mount

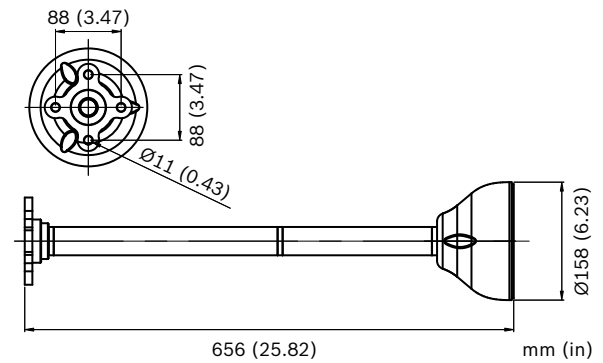

VDA-CMT-DOME –Corner Mount

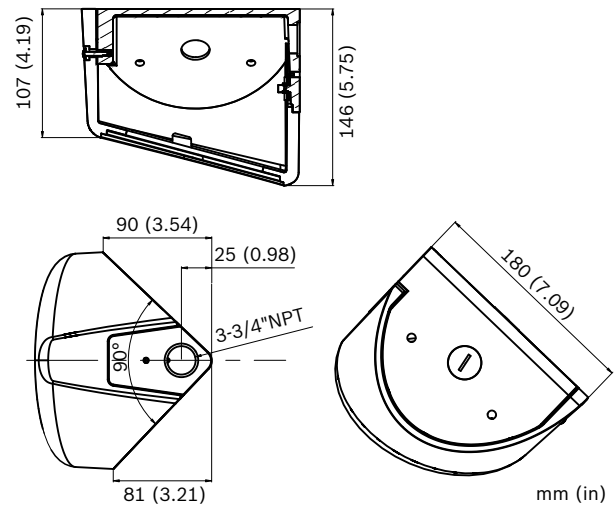

LTC 9213/01 Pole Mount Adapter

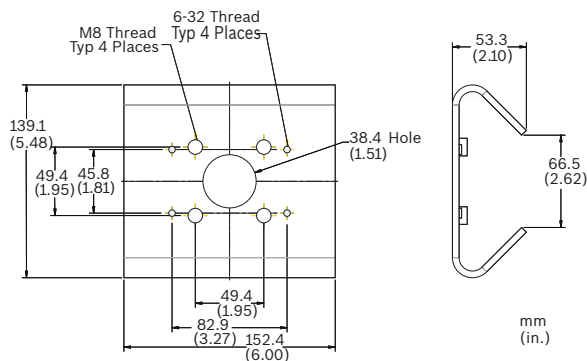

Technical specifications

Electrical

Power Supply	24 VAC 50/60 Hz 12 VDC Power-over-Ethernet 48 VDC nominal
Current Consumption	500 mA 600 mA IVA (12 VDC) 450 mA 500 mA IVA (24 VAC) 150 mA 175 mA IVA (PoE 48 VDC)
Power Consumption	6 W 7.2 W IVA

Sensor

Type	1/3-inch CMOS HD
Active Pixels	1280 x 720

Video streams

Video compression	H.264 (ISO/IEC 14496-10); M-JPEG, JPEG
Streaming	Multiple individually configurable streams in H.264 and M-JPEG, configurable frame rate and bandwidth.
Overall IP Delay	Min. 120 ms, Max. 240 ms

GOP structure	IP, IBP, IBBP
Encoding interval	1 to 60 (50) ips
Resolutions (H x V)	
• 720p HD	1280 x 720
• D1 4:3 (cropped)	704 x 480
• SD upright (cropped)	400 x 720
• 480p SD	Encoding: 704 x 480; Displayed: 854 x 480
• 432p SD	768 x 432
• 288p SD	512 x 288
• 240p SD	Encoding: 352 x 240; Displayed: 432 x 240
• 144p SD	256 x 144
Sensitivity (3200 K, scene reflectivity 89%, 30 IRE)	
Lens 3 - 9 mm (F1.2)	
• Color	0.017 lx (0.0017 fc)
• Monochrome	0.0057 lx (0.00057 fc)
Lens 10 - 23 mm (F1.6)	
• Color	0.03 lx (0.003 fc)
• Monochrome	0.01 lx (0.001 fc)
Day/Night	Color, Monochrome, Auto
White Balance	ATW (2500 to 10000K), ATW hold and manual Indoor and Outdoor ATW
Shutter	Automatic Electronic Shutter (AES) Fixed (1/30 [1/25] to 1/150000) selectable Default shutter
Backlight compensation (IVA)	Off/Auto/IntelligentAE (iAE)
Backlight compensation (non-IVA)	Off/Auto/BLC
Noise reduction	Intelligent Dynamic Noise Reduction (iDNR) with separate temporal and spatial adjustments
Contrast enhancement	On/off
Sharpness	Sharpness enhancement level selectable
Dynamic Range	84 dB typical
Privacy Masking	Four independent areas, fully programmable
Video Motion Analysis	Intelligent Video Analysis

Audio	
Standard	AAC G.711, 8kHz sampling rate L16, 16kHz sampling rate
Signal-to-noise ratio	> 50 dB
Audio Streaming	Full duplex / half duplex
Input/output	
Analog Video out	CVBS (PAL/NTSC), 1 Vpp, BNC, 75 Ohm
Analog Video out (service only)	CVBS (PAL/NTSC), 1 Vpp, 2.5 mm jack, 75 Ohm (non-protected)
Audio	1 x mono line in, 1 x mono line out
• signal line in	12 kOhm typical, 1 Vrms max
• signal line out	1 Vrms at 1.5 kOhm typical,
Alarm	2 inputs
• activation voltage	+5 VDC to +40 VDC (+3.3 VDC with DC-coupled 22 kOhm pull-up resistor)
Relay	1 output
• voltage	30 VAC or +40 VDC Maximum 0.5 A continuous, 10VA

Local Storage

Memory card slot	Supports SDHC and SDXC microSD cards
Recording	Continuous recording, ring recording, alarm/events/schedule recording

Software Control

Unit Configuration	Via web browser or Configuration Manager
Software update	Flash ROM, remote programmable

Network

Protocols	IPv4, IPv6, UDP, TCP, HTTP, HTTPS, RTP, IGMP V2/V3, ICMP, RTSP, FTP, Telnet, ARP, DHCP, SNMP, SNMP (V1, MIB-II), 802.1x, SMTP, iSCSI, UPnP (SSDP)
Encryption	TLS 1.0, SSL, AES (optional)
Ethernet	STP, 10/100 Base-T, auto-sensing, half/full duplex, RJ45
PoE supply	IEEE 802.3at Type-2 compliant
Connectivity	ONVIF Profile S Auto-MDIX

Optical

Lens	3 to 9 mm Automatic Varifocal (AVF) SR lens - or - 10 to 23 mm Automatic Varifocal (AVF) SR lens
Adjustment	Motorized zoom/focus
Iris control	Automatic iris control
Viewing angle (3 to 9 mm)	Wide: 96° x 52° (H x V) Tele: 32° x 18° (H x V)
Viewing angle (10 to 23 mm)	Wide: 28° x 15° (H x V) Tele: 12.4° x 6.9° (H x V)

Mechanical

Dimensions (D x H)	158 x 124 mm (6.22 x 4.89 in)
Weight	0.85 kg (1.87 lb) 1.28 kg (2.82 lb) with SMB
Mounting	Flush mount or surface mount
Color	White (RAL9010) trim ring with black inner liner
Adjustment range	360° pan, 90° tilt, ±90° twist
Dome bubble	Polycarbonate, clear with UV blocking anti-scratch coating
Trim ring	Aluminum

Environmental

Operating temperature	-30 °C to +50 °C (-22 °F to +122 °F)
Cold start temperature	-20 °C (-4 °F)
Storage temperature	-50 °C to +70 °C (-58 °F to +158 °F)
Operating humidity	5% to 93% relative humidity
Storage humidity	Up to 98% relative humidity
Impact protection	EN 50102, IK10
Water/dust protection	IP 66 and NEMA Type 4X
Environmental Test Method	EN 50130-5:2011 Alarm systems Part 5 (Class IV Outdoor in general)

Ordering information**FLEXIDOME HD 720p60 VR 3-9 mm**

1/3-inch CMOS, IP Vandal-Resistant Dome Camera, 720p60, 3-9 mm SR lens
Order number **NIN-733-V03P**

FLEXIDOME HD 720p60 VR 3-9 mm IVA

1/3-inch CMOS, IP Vandal-Resistant Dome Camera, 720p60, 3-9 mm SR lens, IVA
Order number **NIN-733-V03IP**

FLEXIDOME HD 720p60 VR 3-9 mm SMB

1/3-inch CMOS, IP Vandal-Resistant Dome Camera, 720p60, 3-9 mm SR lens, SMB
Order number **NIN-733-V03PS**

FLEXIDOME HD 720p60 VR 3-9 mm IVA SMB

1/3-inch CMOS, IP Vandal-Resistant Dome Camera, 720p60, 3-9 mm SR lens, IVA, SMB
Order number **NIN-733-V03IPS**

FLEXIDOME HD 720p60 VR 10-23 mm

1/3-inch CMOS, IP Vandal-Resistant Dome Camera, 720p60, 10-23 mm SR lens
Order number **NIN-733-V10P**

FLEXIDOME HD 720p60 VR 10-23 mm IVA

1/3-inch CMOS, IP Vandal-Resistant Dome Camera, 720p60, 10-23 mm SR lens, IVA
Order number **NIN-733-V10IP**

FLEXIDOME HD 720p60 VR 10-23 mm SMB

1/3-inch CMOS, IP Vandal-Resistant Dome Camera, 720p60, 10-23 mm SR lens, SMB
Order number **NIN-733-V10PS**

FLEXIDOME HD 720p60 VR 10-23 mm IVA SMB

1/3-inch CMOS, IP Vandal-Resistant Dome Camera, 720p60, 10-23 mm SR lens, IVA, SMB
Order number **NIN-733-V10IPS**

LTC 9213/01 Pole Mount Adapter

Pole mount adapter with stainless steel straps, light gray finish
Order number **LTC 9213/01**

VGA-IC-SP In-ceiling Support Kit for Various Bosch Dome Cameras

Suspended ceiling support kit for various families of Bosch dome cameras
Order number **VGA-IC-SP**

UPA-2420-50 Power Supply

220 VAC, 50 Hz, 24 VAC, 20 VA Out
Order number **UPA-2420-50**

UPA-2430-60 Power Supply

120 VAC, 60 Hz, 24 VAC, 30 VA Out
Order number **UPA-2430-60**

UPA-2450-50 Power Supply, 220 V, 50 Hz

Indoor, 220 VAC, 50 Hz In; 24 VAC, 50 VA Out
Order number **UPA-2450-50**

UPA-2450-60 Power Supply, 120 V, 60 Hz

Indoor, 120 VAC, 60 Hz In; 24 VAC, 50 VA Out
Order number **UPA-2450-60**

S1460 Service/Monitor Cable

2.5 mm connector to BNC for analog and IP cameras, 1 m
Order number **S1460**

VJT-XTCXF

VideoJet XTC XF, H.264 video transcoder
Order number **VJT-XTCXF**

MVS-FENC-AES BVIP AES 128 Bit Encryption

BVIP AES 128-bit encryption site license. This license is required only once per installation. It enables encrypted communication between BVIP devices and management stations.
Order number **MVS-FENC-AES**

Accessories

VDA-WMT-DOME Wall Pendant Mount Bracket

Wall pendant mount bracket for FlexiDome cameras
Order number **VDA-WMT-DOME**

VDA-CMT-DOME Corner Mount Bracket

Corner mount bracket for FlexiDome cameras
Order number **VDA-CMT-DOME**

VDA-PMT-DOME Pendant Pipe Mount Bracket

Pendant pipe mount bracket for FlexiDome cameras
Order number **VDA-PMT-DOME**

VDA-PLEN-DOME In-ceiling Housing for Plenums Kit

FLEXIDOME in-ceiling housing installation kit (plenum-rated) for various FLEXIDOME cameras
Order number **VDA-PLEN-DOME**

VDA-455TBL Tinted bubble

Tinted bubble for FlexiDome series
Order number **VDA-455TBL**

VDA-455CBL Clear bubble

Clear Bubble for FlexiDome series
Order number **VDA-455CBL**

Surface Mount Box FLEXIDOME VR

Surface Mount Box for FLEXIDOME VR Cameras
Order number **VDA-455SMB-IP**

Represented by:

Americas:

Bosch Security Systems, Inc.
130 Perinton Parkway
Fairport, New York, 14450, USA
Phone: +1 800 289 0096
Fax: +1 585 223 9180
security.sales@us.bosch.com
www.boschsecurity.us

Europe, Middle East, Africa:

Bosch Security Systems B.V.
P.O. Box 80002
5617 BA Eindhoven, The Netherlands
Phone: + 31 40 2577 284
Fax: +31 40 2577 330
emea.securitysystems@bosch.com
www.boschsecurity.com

Asia-Pacific:

Robert Bosch (SEA) Pte Ltd, Security Systems
11 Bishan Street 21
Singapore 573943
Phone: +65 6571 2808
Fax: +65 6571 2699
apr.securitysystems@bosch.com
www.boschsecurity.asia

China:

Bosch (Shanghai) Security Systems Ltd.
201 Building, No. 333 Fuquan Road
North IBP
Changning District, Shanghai
200335 China
Phone +86 21 22181111
Fax: +86 21 22182398
www.boschsecurity.com.cn

America Latina:

Robert Bosch Ltda Security Systems Division
Via Anhanguera, Km 98
CEP 13065-900
Campinas, Sao Paulo, Brazil
Phone: +55 19 2103 2860
Fax: +55 19 2103 2862
al.securitysystems@bosch.com
www.boschsecurity.com

PROPOSAL

10/31/2013 7:16

From:
West Coast Security, Inc.
911 Bern Court Ste. 130
San Jose, CA. 95112
1408-318-6182
License # 798959 ACO# 5659

City of Discovery Bay
c/o: HERWIT Engineering
Discovery Bay, CA
Attn: Gregory Harris

Fax: 1-408-904-5940

Services To Be Provided:

QTY	Part Number	Price	Description
1	LABOR	\$1,840.00	Labor to furnish and install outdoor mic/speaker that is connected to the Bosch NVR (quoted on other proposal) for audio recording at customer specified City of Discovery Community Center as discussed with Customer and West Coast Security. WCS to provide and install audi wire for this.
1	LABOR	\$920.00	Labor to configure, program, test and provide basic end user training.
1	AOP-SP-E	\$467.60	Louroe Outdoor, Wall mounted Speakerphone
1	AOP-XD	\$315.00	Louroe Audio Transceiver Interface
1	MATERIAL	\$182.00	Audio Wire
1	MISC	\$81.99	8.5% Sales Tax
1	MISC	\$45.00	Standard Shipping & Handling

- CCTV
- Card Access
- Intercom
- Burglary
- Fire

NOTES: For bi-directional audio from the NVR or a PC running the Operator client software they will have to have a microphone and speakers (On the Bosch DIP-3K this will need to be USB). In the Operator Client will need to perform the steps listed in page 29 & 32-33 of the attached NVR manual. If customer has a wave file customer will need to make sure it can play into the microphone on the Client end when they click on the talk button.

Other

- 1 Audio
- 2
- 3
- 4
- 5
- 6
- 7

FINANCIAL ALTERNATIVES REVIEW

Outright Sale \$3,851.59

- By Others:**
- Infrastructure i.e.: trenching, etc.
 - Power
 - Conduit/Raceways
 - Wire and installation of wire
 - Network infrastructure and network services
 - Painting/Patching
 - Inspections/Permits/Bonds
 - Asbuilts/Submittals
 - Lift(s)
 - PC/Monitor/Keyboard/Mouse for remote viewing of camera system

Total Investment \$3,851.59

Pricing guaranteed for a period of 30 days. Proposal includes all material, installation and training unless otherwise specified. **Proposal does not include shipping and tax unless otherwise specified.** Customer responsible for power and/or network as needed. Any revisions or changes will necessitate a revised proposal. Acceptance is subject to credit approval.

TERMS AND CONDITIONS

- 1) Warranty is 1 year parts from date of installation and/or shipment unless otherwise specified. Repairs resulting from damages caused by others is not covered under Warranty.
- 2) All labor quoted is for normal business hours, Mon-Fri (8am-4:30pm PST). Overtime is at the discretion of West Coast Security, Inc.
- 3) **Payment Terms:** 50% Deposit Due Upon Receipt prior to commencement of work; Progressive Invoice thereafter. Net 30; 2% late fee for payments that are later than 30 days past due.
- 4) WCS assumes all existing equipment to be in good working condition. WCS will notify customer for approval prior to any work being done should existing equipment be in need of repair and/or

ACCEPTANCE OF PROPOSAL

The undersigned acknowledges and agrees to the terms and conditions attached and authorizes the work and/or services.

Authorized Signature: _____ Date: _____

Printed Name: _____

Title: _____ Company: _____



Backbox (plastic) for flush mounting to wall or flat surface



Backbox (metal) for surface mounting to wall or flat surface

DESCRIPTION

Model AOP-SP-E is a wall mount speakerphone designed to provide 2-way audio (listen/talkback) with various modes of audio/video transmission systems such as:

- IP Camera
- DVRs
- Video Servers

Provided with the unit are two back boxes for either flush or surface mounting to a wall. The AOP-SP-E can be used as a stand alone unit or with companion AOP-XD. If used as a stand alone unit, the AOP-SP-E must be powered by a 12Vdc, 500mA power supply. The unit maybe be use for outdoor applications.

The AOP-XD Audio Transceiver unit provides two-way audio with the receiving device (IP Camera, DVR, etc). It also provides power to the AOP-SP-E. It receives the audio signal from the audio output of the receiving device and amplifies it before it goes to the speaker portion of the AOP-SP-E. It also drives the audio signal into the audio input of the receiving device. The AOP-XD contains adjustable level controls for audio signals coming from the AOP-SP-E and receiving device. Two kinds of audio output/input jacks are provided by the AOP-XD (3.5mm mono and RCA) which can be used to accommodate most DVRs, IP Cameras, etc. audio inputs.

OPERATIONS

The gain of the microphone and speaker are factory adjusted. If it is necessary to change the gain of either or both the audio output of the microphone and speaker of the unit, it has to be done in small increments. For adjusting the gain of the microphone, rotate clockwise to increase or counterclockwise to decrease, the potentiometer marked "MIC" slowly until the desired level is attained. Somebody at the head-end has to listen to it while the adjustments are made. If the microphone's gain is too high, it will attenuate the audio output of the speaker. The output of the speaker will then be cutting off as you talk. If this happens, rotate the potentiometer marked "MIC" slowly counterclockwise to decrease the gain of the microphone until the talkback sound at the speaker no longer cuts off.

To adjust the audio output of the speaker, rotate the "SPKR" potentiometer clockwise (increase) or counterclockwise (decrease) slowly until the desired loudness is attained. If the audio from the microphone becomes attenuated, rotate the "SPKR" potentiometer counterclockwise a small increment at a time until the microphone audio becomes louder again.

This unit has a built-in muting system that if the microphone's adjustment (MIC) is too high it is going to mute the speaker. Also if the speaker's adjustment (SPKR) is too high, it's going to mute the microphone.

INSTALLATION AND OPERATING INSTRUCTIONS

WIRING CONNECTION TO SPEAKER AND MICROPHONE OF AOP-SP-E

Color Code of recommended wiring is:

RED - 12Vdc power to microphone
BLACK - Audio Output
BARE - Ground (microphone and speaker)
WHITE - Speaker
Color Code may vary among wire manufacturers

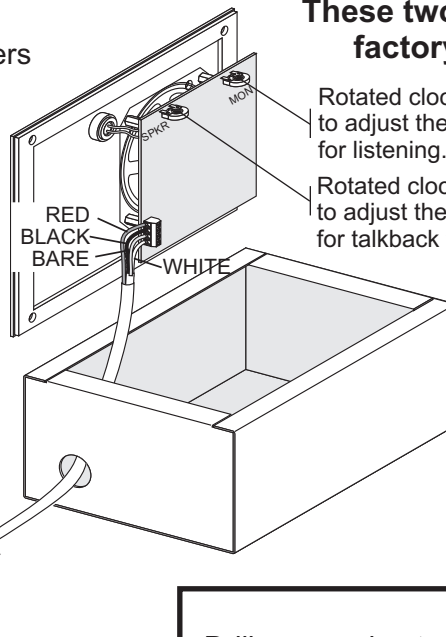

These two potentiometers are factory set but may be:

Rotated clockwise or counter clockwise to adjust the sensitivity of the MICROPHONE for listening.

Rotated clockwise or counter clockwise to adjust the loudness of the SPEAKER for talkback to head-end.

WIRING CONNECTION TO AOP-SP-E

Located on the bottom right side of PC board is a 4-pin terminal block marked A, B, C, SP

A = +12Vdc power
B = Audio output of microphone
C = Ground (microphone and speaker)
SP = Speaker input

Bring one end of recommended cable and connect as follows:

- 1) Connect RED wire to terminal marked "A"
- 2) Connect BLACK wire to terminal marked "B"
- 3) Connect BARE wire to terminal marked "C"
- 4) Connect WHITE wire to terminal marked "SP"

Drill an opening top, bottom or back side of backbox for passing wiring or for connecting conduit.

WIRING CONNECTION FROM AOP-SP-E TO COMPANION AOP-XD AUDIO INTERFACE UNIT

The rear panel of AOP-XD has a 4 pin terminal block marked A, B, C, SP

Bring in other end and connect as follows:

- 1) Red wire to terminal A
- 2) Black wire to terminal B
- 3) Bare wire to terminal C
- 4) White wire to terminal SP

This completes the wiring between the AOP-SP-E and AOP-XD. For operation instructions and functions regarding Model AOP-XD Transceiver Interface unit, refer to the AOP-XD instructions that accompany the unit.

WIRING REQUIREMENTS

- 3 Conductor consisting of:
- 2 Conductor **shielded**, 20 gauge with 22 gauge drain
 - 1 Conductor **unshielded**, 20 gauge
- All in the same jacket

West Penn 358 or equivalent



INSTALLATION AND OPERATING INSTRUCTIONS

INTERCONNECTION DIAGRAM BETWEEN LOUROE MODEL AOP-SP-E AND AOP-XD AUDIO TRANSCEIVER INTERFACE

WIRING REQUIREMENTS

3 Conductor consisting of:

- 2 Conductor **shielded**, 20 gauge with 22 gauge drain
- 1 Conductor **unshielded**, 20 gauge

All in the same jacket

West Penn 358 or equivalent

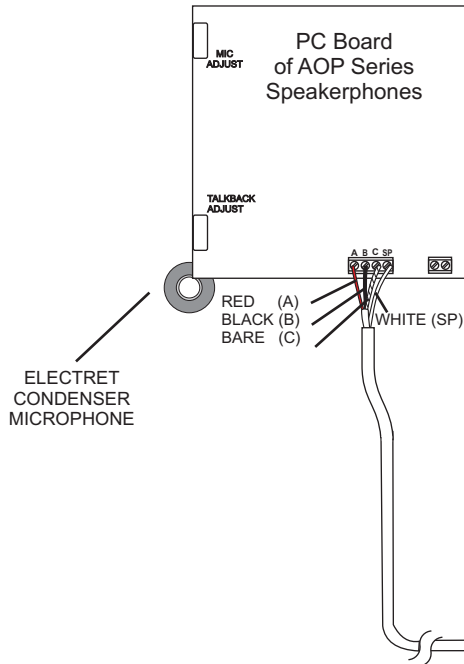



Color Code of recommended wiring is:

- RED - 12Vdc power to microphone
- BLACK - Audio Output
- BARE - Ground (microphone)
- WHITE - Speaker

Terminal Block Identifier

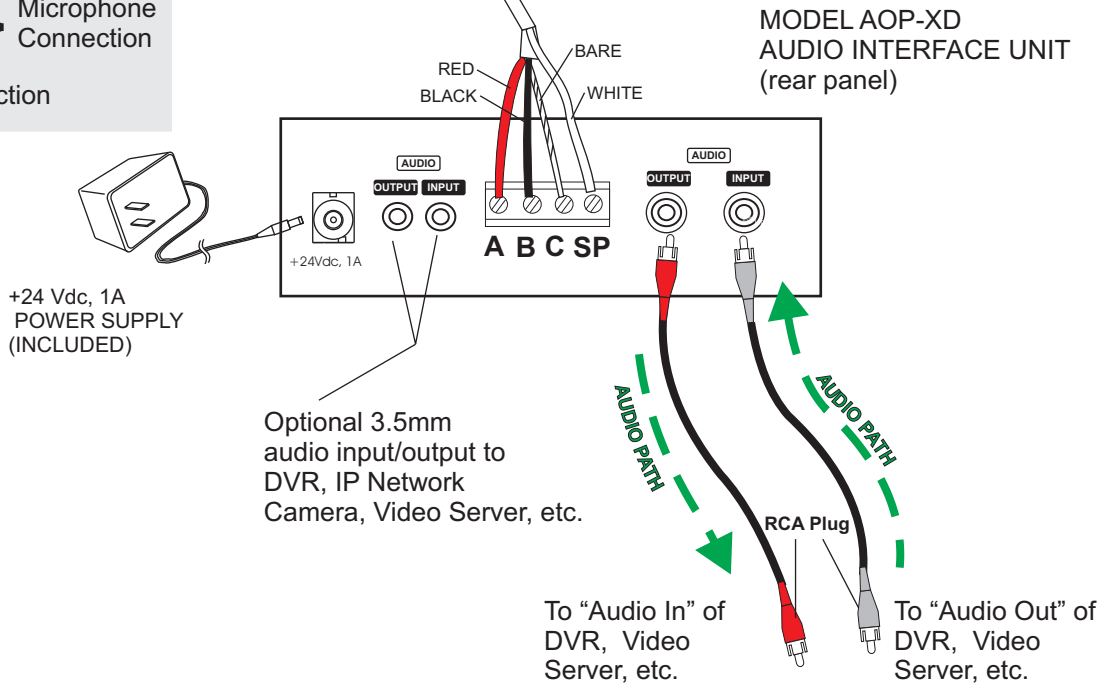
A = 12Vdc power } Microphone Connection
 B = Audio Output }
 C = Ground }
 SP = Speaker Connection



INSTALLATION AND OPERATING INSTRUCTIONS

INTERCONNECTION DIAGRAM CONNECTING LOUROE MODEL AOP-SP-E DIRECTLY TO AN IP CAMERA, DVR,

VIDEO SERVER, ETC. USING 3-COND. SHIELDED CABLE 4-PIN TERMINAL BLOCK IDENTIFIER OF AOP-SP-E (A,B,C,SP)

- A = not used with this application
- (red) B = Audio Output
- () C = Ground (audio) and Ground (speaker) (black wire)
- (white) SP = Speaker output

AOP-XD is not used for this application.

12 Vdc power is required to connect the AOP-SP-E directly to an IP camera or DVR such as AD-1 power supply.
Positive 12Vdc connects to terminal marked "+"
Negative 12 Vdc or ground (with white stripes) connects to terminal marked "GND"

+12Vdc, 500mA power required
(AD-1 power supply included)
Connect to this 2-pin terminal block

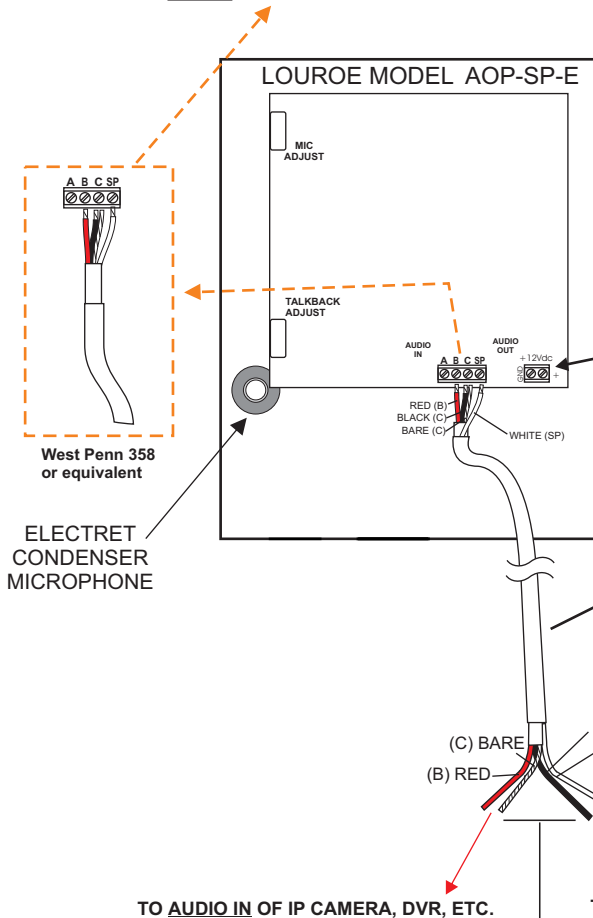

WIRING REQUIREMENTS

3 Conductor consisting of:

- 2 Conductor **shielded**, 20 gauge with 22 gauge drain
- 1 Conductor **unshielded**, 20 gauge

All in the same jacket

West Penn 358 or equivalent

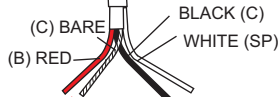

TO AUDIO IN OF IP CAMERA, DVR, ETC.

TO AUDIO OUT OF IP CAMERA, DVR, ETC.

NOTE: BLACK AND BARE WIRES ARE COMMON GROUND

3.5mm STEREO CONNECTION

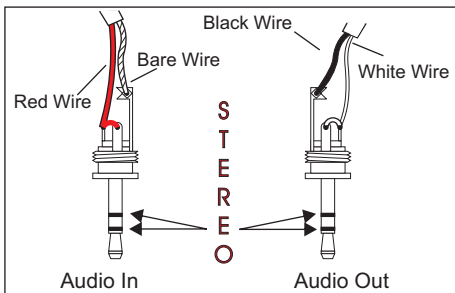

3.5mm MONO CONNECTION

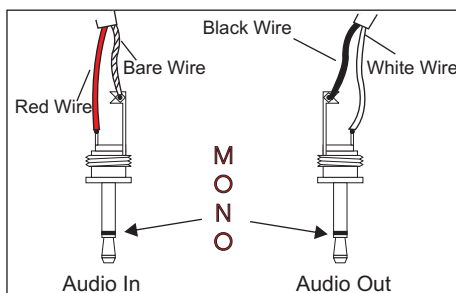

RCA CONNECTION

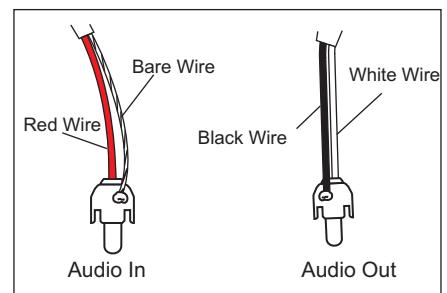

INSTALLATION AND OPERATING INSTRUCTIONS

SPECIFICATIONS (Microphone)

▪ Type	Electret Condenser
▪ Microphone output	line level (0 dB @ 1k Ω)
▪ Microphone element sensitivity	-45dB
▪ Frequency response	40 Hz to 15 kHz \pm 1 dB
▪ Output Impedance	600 Ω unbalanced
▪ Supply voltage	12 Vdc, 500mA

SPECIFICATIONS (Speaker)

▪ Speaker Power output	2W
▪ Speaker Impedance	8 Ω
▪ Speaker magnet	3 oz. ceramic
▪ Speaker size	4" (10cm)
▪ Weight, net	3 Lbs. (1.4 Kg)

SPECIFICATIONS (Mechanical)

▪ Dimensions (Face Plate)	6 1/4"H x 8"W metric (158mm H x 203mm W)
▪ Backbox for AOP-SP-E	
Surface Mount Box (metal)	6 1/4"H x 8"W x 2 3/4"D metric (158mm H x 203mm W x 70mm D)
Flush Mount Box (plastic)	
Backbox Portion	5"H x 6 7/8"W x 2 5/8"D metric (127mm H x 175mm W x 67mm D)
Total including flange	6 1/4"H x 8"W x 2 5/8"D metric (158mm H x 203mm W x 67mm D)

IMPORTANT NOTICE

When this equipment is used as part of an audio monitoring system, the law requires that the public be given notice of AUDIO MONITORING ON THE PREMISES. A decal notice is included with each microphone shipped.



Federal Law References:
Federal Regulations, US Code, Title 18. Crime and Criminal Procedure, Sec 2510.

INSTALLATION AND OPERATING INSTRUCTIONS

NOTES

WARRANTY

LOUROE ELECTRONICS® warrants that at the time of shipment products manufactured by LOUROE ELECTRONICS® to be free of defects in material and workmanship. Should a defect appear within one year (12 months) from date of shipment, LOUROE ELECTRONICS® will, at its sole discretion, repair or replace the defective equipment. This equipment shall not be accepted for repair or return without prior notification by LOUROE ELECTRONICS®.

This warranty does not extend to any Louroe product that has been subjected to improper or incorrect installation, misuse, accident, or in violation of installation instructions provided by LOUROE ELECTRONICS®.

Returned shipments to LOUROE ELECTRONICS® shall be at customer's expense. LOUROE ELECTRONICS® will return the equipment prepaid via best way.

INSTALLATION AND OPERATING INSTRUCTIONS

NOTES

MANUFACTURED
IN THE





visit us at www.ams.net

Price Quote
Order #79744

AMS.NET • 502 Commerce Way • Livermore, CA 94551 • phone (925) 245 - 6100 • fax (925) 245 - 6150

Town of Discovery Bay
Town of Discovery Bay 1800 Willow Lake Road Discovery Bay, CA 94505
ATTN: Virgil Koehne Phone: (925) 634-1131 Fax: (925) 513-2705

Community Center - Video Surveillance VideoIQ

Order	Project	Modified	Ship Via	Account Mgr.
79744	75577	9/25/2013		Jeff Land

Products

	Item Description	Taxable	Qty	Unit Price	Total
	iCVR HD Camera with Intelligent Video Analytics The iCVR-HD cameras uniquely store full 1080p video in up to 320 GB of onboard NVR storage. This eliminates the need to continuously stream video to central storage — reducing network traffic and bandwidth consumption by over 90%.				
1	iCVR™Outdoor full HD1080p dome 320GBHD 3-8mm len Part #VIQ-HD-CRD232-3-8 VideoIQ, Inc. IP Video Surveillance IP Video Surveillance	Y	3	\$1,664.99	\$4,994.97
	POE Switch				
2	Cisco Catalyst 3560-PC- 8port SFP 802.3af PWR Part #WS-C3560-8PC-S Cisco Systems Inc. Cisco Catalyst 3500 Series Switches (Cisco Only)	Y	1	\$920.70	\$920.70
3	Cross-Over Patch Cable (5') - Black Part #CAT5CROSSBK TriNet Communications Cross-over Patch Cable - Copper	Y	6	\$5.33	\$31.98
Products Total					\$5,947.65

Labor

	Item Description	Taxable	Qty	Unit Price	Total
1	<p>Configuration (VideoIQ View Software)</p> <p>AMS.net will configure Surveillance services throughout the site with broadcast capabilities over the IP infrastructure. AMS.NET will configure to provide recording, and storage for the Camera System. Retention time will be determined by how much storage capacity of each servers. AMS.NET will download the VideoIQ View software on the customer's existing workstation and configure cameras the with IP address for network connectivity. ** Camera cabling and or mounting is not included in this quote. A seperate cabling quote will be provided by AMS.NET Cabling Dept. based on site walk if needed. Complete testing.</p>	n/a	1	\$1,200.00	\$1,200.00
2	<p>Professional Services - Cisco Edge Switch Installation - Stackable</p> <p>Professional services provided by AMS.NET for the installation and configuration of the new Cisco 2900,3600,3700 Series 10/100/1000MB edge switch.</p> <p>The switch will be mounted, connected, and configured to support Voice Over IP and QoS. AMS.NET will setup an Auxiliary VLAN that will contain all voice data.</p>	n/a	1	\$400.00	\$400.00
3	<p>Professional Services - IP Camera</p> <p>AMS.NET will perform software installation and configuration of Cameras as per the site survey and client requirements.</p> <p>AMS.NET will set up grids, camera rules and schedules on the digital video recorder. Locations and coverage will be as per the Pre-Installation meeting.</p> <p>AMS.NET will perform complete testing</p> <p>This labor scope does not include mounting, alignment and focus of cameras for optimum performance. This will be priced separately.</p> <p>** Camera cabling is not included in this labor scope. A separate cabling quote will be provided by AMS.NET Cabling Dept. based on site walk. Complete testing.</p> <p>NOTE: If customer requires additional changes to the camera positions after initial install, AMS.NET will charge the client \$ 125.00 per hour for this labor.</p>	n/a	3	\$150.00	\$450.00
4	<p>Video Surveillance Training 1/2 Day (4 Hours)</p> <p>Onsite customer training for administration, operation and review of Surveillance Solution. 4 hours of training will be provided by AMS.NET's Video Surveillance Engineer</p>	n/a	1	\$800.00	\$800.00
Labor Total					\$2,850.00

Terms and Conditions Below

Order Summary

Products Total	\$ 5,947.65
Taxable Total	\$ 5,947.65
Shipping/Handling	\$ 60.11
Taxes (8.50%)	\$ 510.66
Labor Total	\$ 2,850.00
Total	\$ 9,368.42

1. AMS.NET will require a Purchase Order referencing this Quote # or if a Purchase order is not provided, an authorized representative must sign this quote.
2. Payment terms are Net 30. Payment made beyond 30 days are subject to a finance charger of 1.5% per month. Customer agrees to pay all collections costs and attorney fees or late payments if applicable. Customer agrees to accept multiple invoices for projects that cover multiple sales. In the event that a site's readiness is delayed by the customer, customer agrees to accept and pay invoices that reflect equipment and services already received.
3. Shipping charges and sales tax will be added to this order when invoiced and the customer agrees to pay these charges.
4. All companies with tax exemption must present a valid Tax Exempt form. If Customer is tax exempt or if tax exempt form is not provided then customer agrees to pay all applicable taxes.
5. All shipments are FOB Origin or Pre-paid and shipped to Dock. Any Special shipping requirements must be clearly stated on all PO's (i.e. inside delivery). If inside Delivery or Lift-gate is required it must be specified and additional fees will incur. Shipping charges that appear on this quote are an estimate, AMS.NET will invoice and the customer will pay the actual shipping charge when identified.
6. Upon delivery of equipment, customer agrees to open all shipments and visually inspect equipment for physical damages. All damages must be reported to AMS.NET within 24 hours of delivery.
7. Returns will be accepted at AMS.NET discretion and only if merchandise is in an unopened box and the customer agrees to pay a restocking fee of 25% of the purchase price. All returns must have a valid RMA number from AMS.NET before returning.

Please fax signed Quotation or Purchase Order to your AMS.NET account manager or to 925.245.6150. Full terms and conditions can be viewed on our website at www.ams.net/services/procurement_financing/

AMS.NET Tax ID: 94-3291629

C7 License: 763508

8. The laws of the State of California will apply to this sale.
9. The term "installation date" means the first business day on which installation of the system is complete. Minor omissions or variances in performance of the System that do not materially or adversely affect the operation of the system, shall not be deemed to have postponed the Installation Date. Seller shall use its best efforts to make timely delivery and installation. However, all stated delivery and installation dates are approximate and except as expressly provided in this agreement, Seller shall, under no circumstance, be deemed to be in default hereunder or be liable for consequential, incidental or special damages or commercial loss resulting from delays in delivery or installation.
10. Warranties. AMS warrants to Customer that it has good title to the equipment being sold to Customer under this Agreement, and the right to sell such equipment to Customer free of liens or encumbrances. AMS further warrants to Customer that the equipment being sold to Customer hereunder shall be free from defects in workmanship for a warranty period of thirty (30) days commencing on the later date the equipment is delivered to Customer or the date upon which AMS completes performance of the services to be performed under this agreement (this warranty being hereinafter referred to as an "Installation Warranty"). Except as expressly set forth in this paragraph, AMS does not make, and hereby disclaims, any and all representations or warranties, express or implied, with respect to the equipment or services being provided under this agreement, including but not limited to any implied warranties of merchantability, fitness for a particular purpose, satisfactory quality, against infringement, or arising from a course of dealing, usage or trade practice. AMS shall reasonably cooperate and assist Customer in enforcing any manufacturer warranties with respect to the equipment being sold to Customer under this Agreement. AMS hereby advises Customer, and Customer acknowledges that in the event Customer desires to procure from AMS any warranty protection beyond the warranty of title and the Installation Warranty provided under this Paragraph, Customer may do so by entering into a separate Service Agreement with AMS.

Manufacturer's warranty that is guaranteed is whatever is published by the manufacturer at the time of purchase.

Authorized Signature: _____ **Date:** _____

Print Name: _____ **Print Title:** _____



No Back Up
Documentation
For Agenda Item # G-2



No Back Up
Documentation
For Agenda Item # H



No Back Up
Documentation
For Agenda Item # I



No Back Up
Documentation
For Agenda Item # J



No Back Up
Documentation
For Agenda Item # K



No Back Up
Documentation
For Agenda Item # L-1

**Discovery Bay
P-6 Zone Citizen
Advisory
Committee**

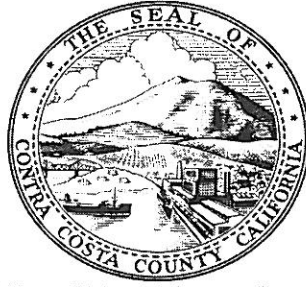

Office of Supervisor Mary N. Piepho
Contact: Karyn Cornell
181 Sand Creek Road, Suite L
Brentwood, CA 94513
925-240-7260

Respectfully submitted by: _____

DRAFT

The Discovery Bay P-6 Zone Citizen Advisory Committee serves as an advisory body to the Contra Costa County Board of Supervisors and the County Planning Agency.

Record of Actions

Meeting start time: 7:32 p.m.

Wednesday, July 17, 2013

1.) Meeting called to order by Vice Chair Kane at 7:32 p.m. with Committee members Stevens, Zeigler present.

2.) **Public Comment:** None Received.

3.) **Review of Record of Actions of October 30, 2012 meeting:** Committee member Stevens made a motion to accept the Record of Actions as prepared. Second made by Committee member Zeigler. Motion carried 3-0.

4.) Correspondence: (Key: R= Received S= Sent)

R- 5/2/13 Supervisor Piepho to Sheriff Livingston regarding DB P-6 Zone CAC recommendation for 2013-2014 Byron Union School District SRO position funding
R-5/15/13 Sheriff Livingston to Supervisor Piepho regarding DB P-6 Zone CAC recommendation for 2013-2014 Byron Union School District SRO position funding
R-6/3/13 Supervisor Piepho to Byron Union School District regarding 2013-2014 Byron Union School District SRO position funding
R-6/3/13 Byron Union School District to Sheriff Livingston regarding 2013-2013 Byron Union School District SRO position funding
R-6/26/13 Sheriff Livingston to Byron Union School District regarding 2013-2014 Byron Union School District SRO position funding

5.) Old Business:

- a.) **Discuss DB P-6 Zone CAC Budget:** Lt. Johnson provided projected budget information for fiscal year 13/14 as well as current fiscal year 12/13 information and previous fiscal year information 11/12. Discussion by member Zeigler regarding the current fund balance. Lt. Johnson provided overview regarding the cost of Resident Deputies vs. Jr. Deputies. Discussion regarding air support cost and the portion Discovery Bay contributes. Request from Committee Member Zeigler to verify budget numbers. Lt. Johnson will work to supply additional information.
- b.) **Discuss Byron Union School District School Resource Officer Funding:** Lt. Johnson provided overview of the Sheriff's proposal for the position for the current school year with the

This meeting record is provided pursuant to Better Government Ordinance 95-6, Article 25-2.205(d) of the Contra Costa County Ordinance Code.

allocation of \$117,964.80 which will cover six and a half months with the request that the Byron Union School District provide the remainder of the funding for the school year. Debbie Burnett, the new Superintendent for the District, provided an update at this time the school district was unable to commit funding but were working on various fundraising opportunities and researching grant funding. All parties involved stated the benefit the position supplied to the schools

7.) New Business

- a.) Monthly Activity Report (Lt. Johnson): Lt. Johnson provided the statistics and discussed several different arrests made in connection with burglaries in the community. There has been an uptick in thefts involving catalytic converters as well as boating under the influence incidents. Lt. Johnson discussed a possible lead regarding a smaller foreign car in either champagne or silver with several individuals possibly connected with several incidents. He also discussed the new tools several of the Sheriff's vehicles have been equipped with that are able to scan license plates and provide information including whether or not they are stolen.
- b.) Other new Business: None.

8.) Future agenda items/Committee Member Comments:

- a.) DB P-6 Zone Budget
- b.) Byron Union School District School Resource Officer Funding

9.) Adjourn: Meeting adjourned at 8:07p.m. to the next meeting scheduled for October 14th at 7:30p.m.

Byron Municipal Advisory Council

*Not Recorded

DRAFT

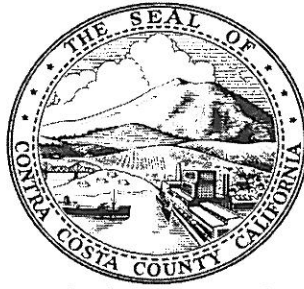

Office of Supervisor Mary N. Piepho
Contact: Karyn Cornell
3361 Walnut Blvd. Suite 140
Brentwood, CA 94513
925-240-7260

Respectfully submitted by: _____

*The Byron Municipal Advisory Council serves as an advisory body to the
Contra Costa County Board of Supervisors and the County Planning Agency.*

Record of Actions

Meeting start time: 6:00 p.m.

Thursday, August 15, 2013

1.) Meeting called to order by Chair Juarez at 6:00p.m. Vice Chair Schmit absent.

2.) **Public Comment:** Erica Rodriguez-Langley, from Assembly member Frazier office reintroduced herself to the community and discussed several upcoming events the Assembly member will be hosting. Liz Fuller from the Brentwood Library discussed the Strategic Plan Update currently taking place and several upcoming Town Halls the Library will be holding to gain further input from the community. Mike Niesen announced that he would be celebrating 25 years of service on the Byron Sanitary District Board. Linda Thuman discussed her concerns regarding the Sand Hill Ranch motorcross area and the quality of life impacts for surrounding neighbors. Rick Kendrick also discussed his concerns with Sand Hill Ranch and that there must be compliance with the conditions of approval. Assembly member Frazier introduced himself and provided a brief overview of several of the issues he is working on including transportation projects and Delta matters.

3.) **Review of Record of Actions of 6-20-13 meeting:** Councilmember Lopez made a motion to accept the Record of Actions with a deletion of duplicated information in item 4d. Second made by Councilmember Larsen. Motion carried 4-0.

4.) Agency Reports

a.) **East Contra Costa Fire Protection District:** Field Representative Cornell distributed the monthly report.

b.) **Contra Costa County Sheriff's Department:** Lt. Johnson presented the calls for July. There were 4 residential burglaries in the community all in vacant homes. He asked that the community contact the Sheriff's office if they see any suspicious activity.

c.) **California Highway Patrol:** No Report

d.) **Office of Supervisor Mary N. Piepho:** Field Representative Cornell provided an update on the following items: Field Representative Cornell provided an update on the following items: Trilink-Working to discuss phases and makeup of governance model. Scheduling for a staff presentation in the fall; Community Warning System: Wednesday 28th conducting a large scale public test; CCC Workforce Development Board is hosting a free Business Briefing and Networking event. August 23 from 2-5:30 in Pleasant Hill; distributed copies of correspondence Supervisor Piepho sent in support for a grant application for additional funding for the Camino Diablo/Byron Highway project; provided copies of the August 19th Zoning Administrator agenda; provided copies of the East County HCP 2012 Year in Review and announced that their next meeting is scheduled for September 22nd.

5.) Items for Discussion and/or Action

a.) **Discuss Byron area Park Dedication funds:** Current balance for the Byron area is \$42,777. Motion made by Councilmember Lopez to form a Park Dedication Subcommittee made up of Councilmembers Beltran and Larsen. Second made by Chair Juarez. Motion carried 4-0. The subcommittee will work to have an update for the October meeting.

6.) Correspondence Key: R= Received S= Sent

- a. R-7/22/13 Town of Discovery Bay CSD Updates Directors and Nominated Officers
- b. R-7/23/13 Contra Costa County Planning Commission Cancellation Notice for July 23
- c. R-8/5/13 Contra Costa County Zoning Administrator Agenda for August 5
- d. R-8/13/13 Contra Costa County Planning Commission Agenda for August 13

This meeting record is provided pursuant to Better Government Ordinance 95-6, Article 25-2.205(d) of the Contra Costa County Ordinance Code.

e. R-8/14/14 Contra Costa Local Agency Formation Commission Agenda for August 14

7.) Councilmember Comment/Future Agenda Item:

a.) Agency Comment Request for LP13-2095

8.) Adjourned to next meeting scheduled for September 26, 2013 at 6:00p.m.



No Back Up
Documentation
For Agenda Item # N-1



No Back Up
Documentation
For Agenda Item # 0